



Medium voltage products

VD4

Medium voltage vacuum circuit-breakers 12...36 kV - 630...3150 A - 16...50 kA

Provided by Northeast Power Systems, Inc.
www.nepsi.com

Power and productivity
for a better world™



Index

4	1. Description
12	2. Selection and ordering
64	3. Specific product characteristics
68	4. Overall dimensions
95	5. Electric circuit diagram

1. Description

The new VD4 are a synthesis of renowned technology in designing and constructing vacuum interrupters embedded in poles, and excellency in design, engineering and production of circuit-breakers.

The VD4 medium voltage circuit-breakers use vacuum interrupters embedded in the poles. This construction technique makes the circuit-breaker poles particularly sturdy and protects the interrupter from impacts, dust deposits and humidity. The vacuum interrupter houses the contacts and makes up the interrupting chamber.

Current interruption in vacuum

The vacuum circuit-breaker does not require an interrupting and insulating medium. In fact, the interrupters do not contain ionisable material.

In any case, on separation of the contacts an electric arc is generated made up exclusively of melted and vaporised contact material.

The electric arc remains supported by the external energy until the current is cancelled in the vicinity of natural zero. At that instant, the rapid reduction in the load density carried and the rapid condensation of the metallic vapour, leads to extremely rapid recovery of the dielectric characteristics.

The vacuum interrupter therefore recovers the insulating capacity and the capacity to withstand the transient recovery voltage, definitively extinguishing the arc.

Since high dielectric strength can be reached in the vacuum,

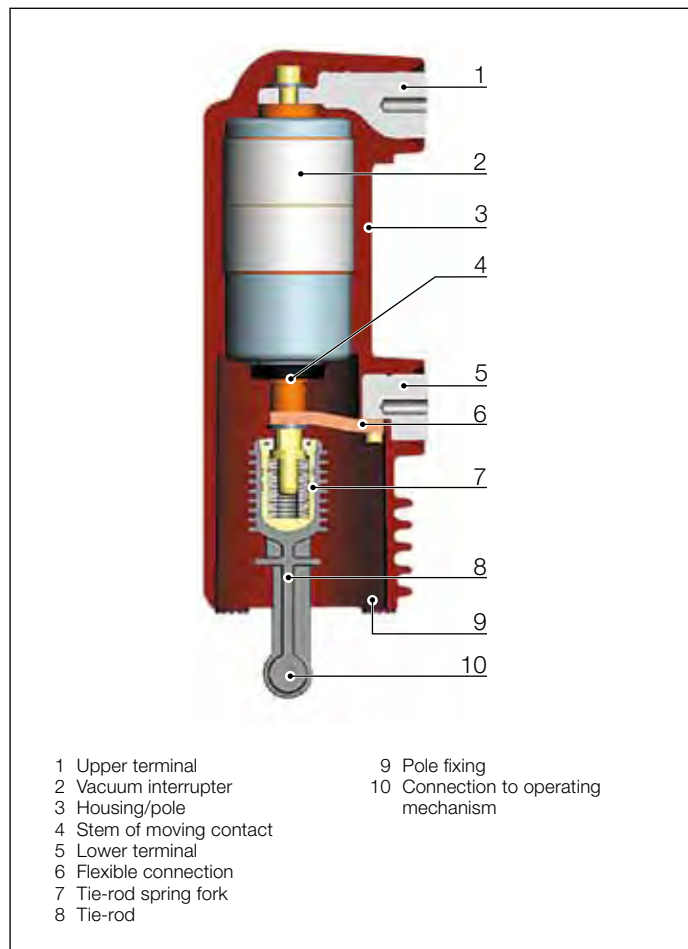

Vacuum interrupter embedded in the pole

- Vacuum interruption technique
- Vacuum contacts protected against oxidation and contamination
- Vacuum interrupter embedded in the pole
- Interrupter protected against shocks, dust and humidity
- Operation under different climatic conditions
- Limited switching energy
- Stored energy operating mechanism with anti-pumping device supplied as standard
- Simple customisation with a complete range of accessories
- Fixed and withdrawable version
- Compact dimensions
- Sealed-for-life poles
- Sturdiness and reliability
- Limited maintenance
- Circuit-breaker racking in and racking out with door closed
- Incorrect and hazardous operations are prevented thanks to special locks in the operating mechanism and in the truck
- High environmental compatibility

even with minimum distances, interruption of the circuit is also guaranteed when separation of the contacts takes place a few milliseconds before passage of the current through natural zero.

The special geometry of the contacts and the material used, as well as the limited duration and low voltage of the arc, guarantee minimum contact wear and long life. Furthermore, the vacuum prevents their oxidation and contamination.

Operating mechanism

The low speed of the contacts, together with the reduced run and low mass, limit the energy required for the operation and therefore guarantee extremely limited wear of the system.

The circuit-breaker therefore only requires limited maintenance.

The VD4 circuit-breakers use a mechanical operating

mechanism, with stored energy and free trip.

These characteristics allow opening and closing operations independent of the operator. The operating mechanism is of simple conception and use and can be customised with a wide range of accessories which are easy and rapid to install. This simplicity converts into greater reliability of the apparatus.

The structure

The operating mechanism and the poles are fixed to a metal frame which is also the support for the fixed version of the circuit-breaker. The compact structure ensures sturdiness and mechanical reliability.

Apart from the isolating contacts and the cord with plug for connection of the auxiliary circuits, the withdrawable version is completed with the truck for racking it into and out of the switchgear or enclosure with the door closed.



1. Description

Quenching principle of ABB interrupters

In a vacuum interrupter, the electric arc starts at the moment of contact separation and is maintained until zero current and can be influenced by magnetic fields.

Vacuum arc – diffuse or contracted

Following contact separation, single melting points form over the entire surface of the cathode, producing metal vapours which support the arc.

The diffuse vacuum arc is characterised by expansion over the contact surface and by an even distribution of thermal stress on the contact surfaces.

At the rated current of the vacuum interrupter, the electric arc is always of the diffuse type. Contact erosion is very limited and the number of current interruptions very high.

As the interrupted current value increases (above the rated value), the electric arc tends to be transformed from the diffuse into the contracted type, due to the Hall effect. Starting at the anode, the arc contracts and as the current rises further it tends to become sharply defined. Near the area involved there is an increase in temperature with consequent thermal stress on the contact.

To prevent overheating and erosion of the contacts, the arc is kept rotating. With arc rotation it becomes similar to a moving conductor which the current passes through.

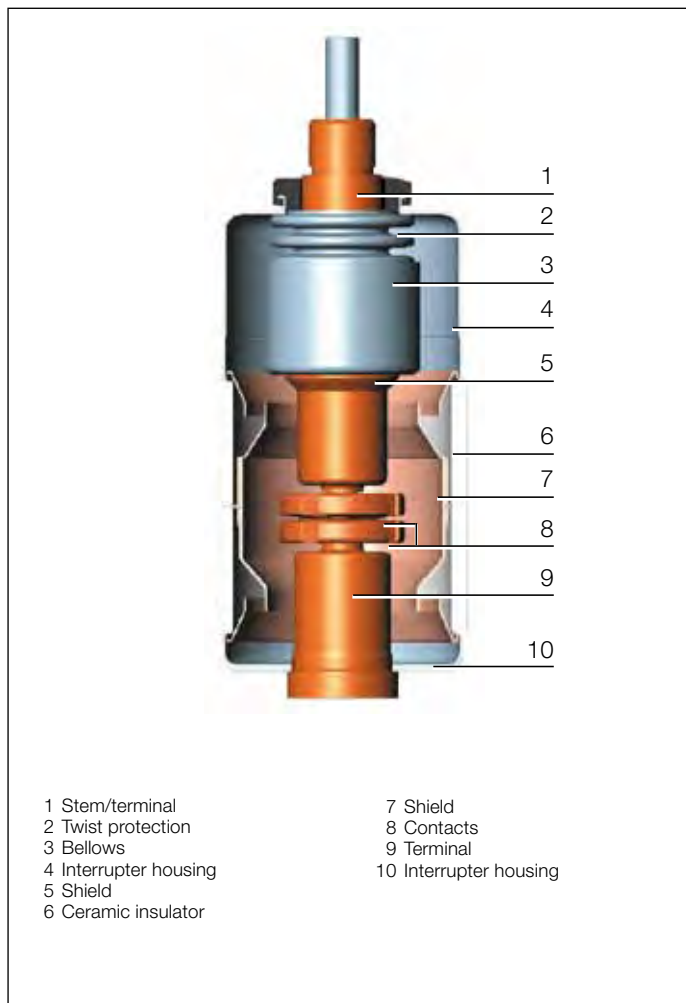

- | | |
|-----------------------|------------------------|
| 1 Stem/terminal | 7 Shield |
| 2 Twist protection | 8 Contacts |
| 3 Bellows | 9 Terminal |
| 4 Interrupter housing | 10 Interrupter housing |
| 5 Shield | |
| 6 Ceramic insulator | |

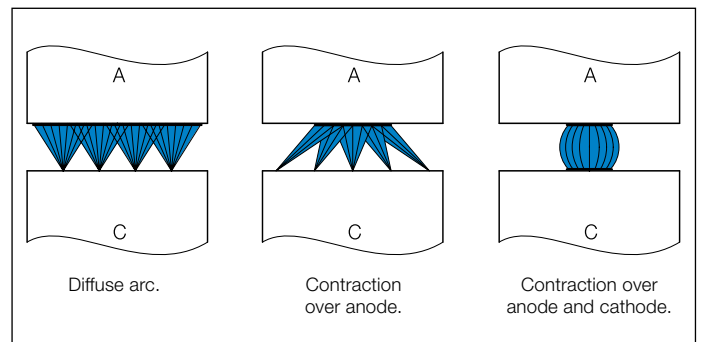

Schematic diagram of the transition from a diffuse arc to a contracted arc in a vacuum interrupter.

Vacuum interrupter

The spiral geometry of ABB vacuum interrupter contacts

The special geometry of the spiral contacts generates a radial magnetic field in all areas of the arc column, concentrated over the contact circumferences.

An electromagnetic force is self-generated and this acts tangentially, causing rapid arc rotation around the contact axis.

This means the arc is forced to rotate and to involve a wider surface than that of a fixed contracted arc.

Apart from minimising thermal stress on the contacts, all this makes contact erosion negligible and, above all, allows the interruption process to be controlled even with very high short-circuits.

ABB vacuum interrupters are zero-current interrupters and are free of any re-striking.

Rapid reduction in the current charge and rapid condensation of the metal vapours simultaneously with the zero current, allows maximum dielectric strength to be restored between the interrupter contacts within microseconds.

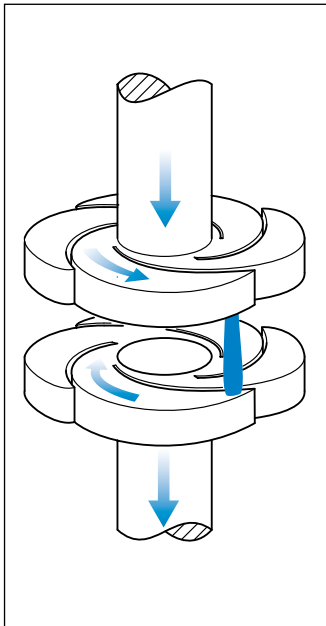

Radial magnetic field contact arrangement with a rotating vacuum arc.

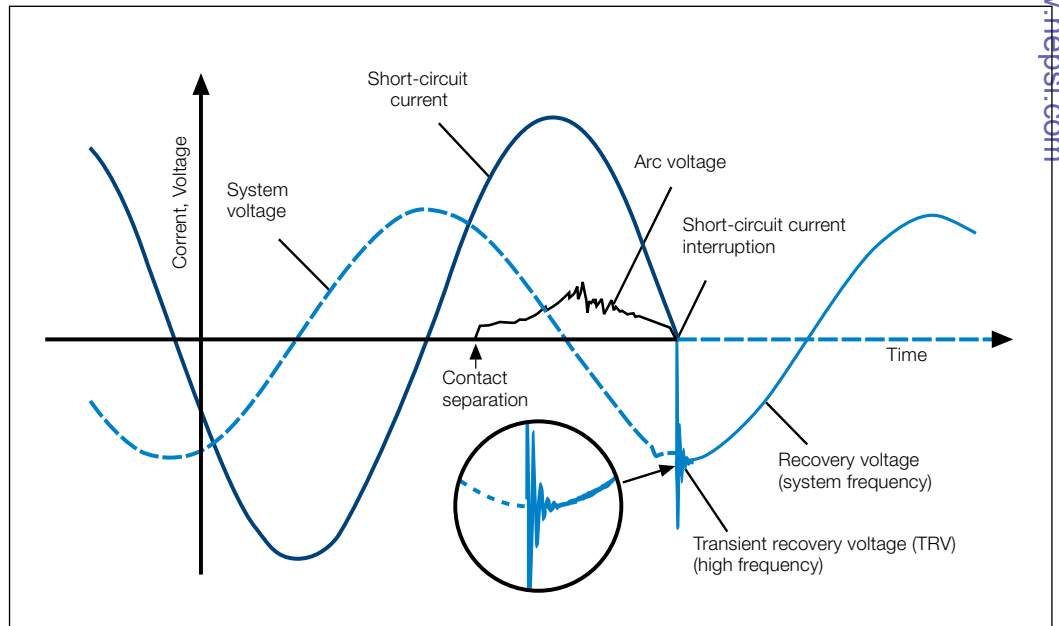

Development of current and voltage trends during a single phase vacuum interruption process.

1. Description

Versions available

The VD4 circuit-breakers are available in the fixed and withdrawable version with front operating mechanism. The withdrawable version is available for UniGear ZS1, ZS8.2 and UniSec switchgear and for PowerCube and Powerbloc enclosures.

Fields of application

The VD4 circuit-breakers are used in power distribution for control and protection of cables, overhead lines, transformer and distribution substations, motors, transformers, generators and capacitor banks.

Standards

The VD4 circuit-breakers comply with the IEC 62271-100, VDE 0671-part. 100, CEI EN 62271-100 file 7642 (2005-5) Standards and with those of the major industrialised countries.

The VD4 circuit-breakers have undergone the tests indicated below and guarantee the safety and reliability of the apparatus in service in any installation.

- **Type tests:** heating, withstand insulation at power frequency, withstand insulation at lightning impulse, short-time and peak withstand current, mechanical life, short-circuit current making and breaking capacity.
- **Individual tests:** insulation of the main circuits with voltage at power frequency, auxiliary circuit and operating mechanism insulation, measurement of the main circuit resistance, mechanical and electrical operation.

Service safety

Thanks to the complete range of mechanical and electrical locks (available on request), it is possible to construct safe distribution switchgear with the VD4 circuit-breakers.

The locking devices have been studied to prevent incorrect operations and to inspect the installations whilst guaranteeing maximum operator safety.

Key locks or padlock devices enable opening and closing operations and/or racking in and racking out.

The racking-out device with the door closed allows the circuit-breaker to be racked into or out of the switchgear only with the door closed.

Anti-racking-in locks prevent circuit-breakers with different rated currents from being racked in, and the racking-in and racking out operation with the circuit-breaker closed.

- **Highly reliable operating mechanisms thanks to a low number of components which are manufactured using production systems for large quantities**
- **Extremely limited and simple maintenance**
- **Accessories common to the entire range**
- **Electrical accessories that can be easily and quickly installed or replaced thanks to wiring pre-engineered with plug-socket connectors**
- **Mechanical anti-pumping device is supplied as standard**
- **Built-in closing spring charging lever**
- **Key lock with circuit-breaker open**
- **Protective covering over the opening and closing pushbuttons to be operated using a special tool**
- **Padlock device on the operating pushbuttons**

Accessories

The VD4 circuit-breakers have a complete range of accessories to satisfy all installation requirements. The operating mechanism has a standardised range of accessories and spare parts which are easy to identify and order.

The accessories are installed conveniently from the front of the circuit-breaker. Electrical connection is carried out with plug-socket connectors.

Use, maintenance and service of the apparatus are simple and require limited use of resources.

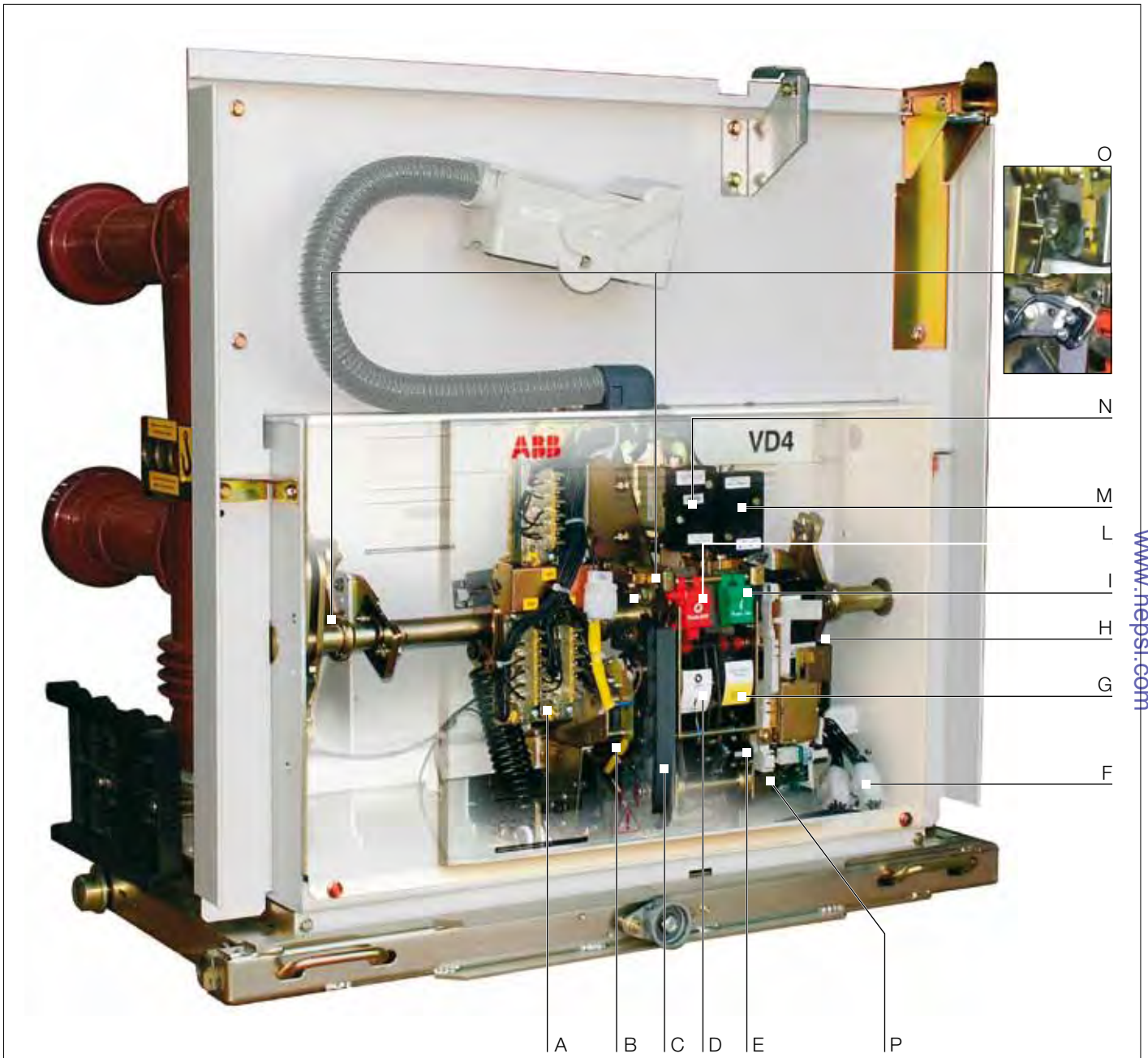

Circuit-breaker operating mechanism

- | | |
|---|---|
| <ul style="list-style-type: none"> A Open/closed auxiliary contacts B Geared motor for closing spring charging C Built-in closing spring charging lever D Mechanical signalling device for circuit-breaker open/closed E Mechanical operation counter F Plug-socket connectors of electrical accessories in the truck | <ul style="list-style-type: none"> G Signalling device for closing springs charged/discharged H Service releases I Closing pushbutton L Opening pushbutton M Operating mechanism locking electromagnet N Additional shunt opening release O Transient contact P Contacts for signalling spring charged/discharged |
|---|---|

1. Description

General characteristics of the complete VD4 series (*)

The VD4 series of vacuum circuit-breakers conform to the specifications of the following standards:

- VDE 00670, part 1000 IEC 62271-1
- VDE 00671, part 100 IEC 62271-100
- CEI EN 62271-100 File 7642 (2005-5)

(*) For information about the 12 kV • 1250 ... 4000 A • 50/63 kA and 36/40.5 kV • 630 ... 2500 A • 16 ... 40 kA circuit-breakers, please see technical catalogue GCBA520PO102.



Rated voltage ⁽¹⁾	kV	12			
Rated frequency	Hz	50 - 60			
Rated normal current	A	630 . . . 4000 ⁽²⁾			
Short-time withstand current and breaking capacity	kA	16 ... 31.5	40	50	63
Making capacity	kA	40 ... 80	100	125 ⁽³⁾	158
Short-time withstand current	s	3	3	3	3
Fixed / withdrawable version		•/•	•/•	•/•	• / -
Maximum overall dimensions (fixed version)	d (mm)	150 - 275	210 - 275	210 - 275	275
	H (mm)	205 - 310	310	310	310
	a (mm)	450 - 700	570 - 700	600 - 750	750
	b (mm)	424	424	459	459
	c (mm)	461 - 599	599 ⁽⁵⁾	608 ⁽⁷⁾	677
Weight	kg	73 - 105	94 - 180	147 - 260	260
Embedded poles		•	•	•	-
Assembled poles		-	-	-	•

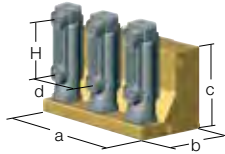

Provided by Northeast Power Systems, Inc.
www.nepsi.com

Technical documentation

To go into technical and application aspects of the VD4 circuit-breakers in depth, please ask us for the following publications:

- PowerCube modules code 1VCP000091
- Powerbloc modules code BA441/03E
- UniGear ZS1 switchgear code 1VCP000138
- ZS8.4 switchgear code L2288
- REF542*plus* unit code 1VTA100001
- PR512 protection unit code 1VCP000055

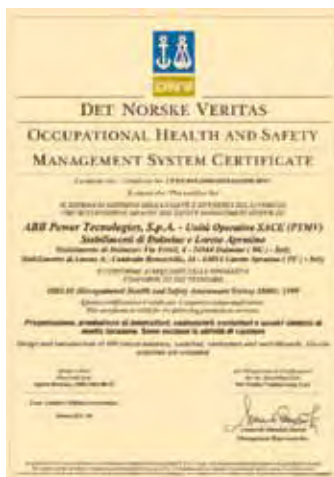



	17.5	24	36	40,5
	50 - 60	50 - 60	50-60	50-60
	630 ... 4000 ⁽²⁾	630 ... 3150 ⁽²⁾	630 ... 3150	630 ... 3150
	16 ... 31.5	40 ... 50	16 ... 31.5	16 ... 40
	40 ... 80	100 ... 125	40 ... 80	40 ... 100
	3	3	3	4
	•/•	•/•	•/•	•/•
	150 - 275	210 - 275	210 - 275	280 - 360 ⁽⁴⁾
	205 - 310	310	310	328
	450 - 700	570 - 700	570 - 700	786 / 853 ⁽⁶⁾
	424	424	424	895 ⁽⁶⁾ - 1000
	461 - 599 ⁽⁵⁾	599 ^{(5) (7)}	631 - 661	492 / 789 ⁽⁶⁾
	73 - 105	94 - 180	100 - 110	555 - 686 ⁽⁶⁾
	•	•	•	1575
	-	-	-	290 - 350
	•	•	•	•
	-	-	-	•

- ⁽¹⁾ Test voltage according to IEC 62271-1 Standards table 1a, VDE 0670, - part 1000, list 2
- ⁽²⁾ With forced ventilation
- ⁽³⁾ Higher values on request
- ⁽⁴⁾ 360 mm for fixed version, 280 mm for withdrawable version
- ⁽⁵⁾ Circuit-breaker with eat sink 616 mm (2500 A)
- ⁽⁶⁾ Withdrawable version
- ⁽⁷⁾ Circuit-breaker with eat sink 634 mm (3150 A)

Quality System

Complies with ISO 9001 Standards, certified by an independent organisation.

Test Laboratory

Complies with UNI CEI EN ISO/IEC 17025 Standards, accredited by an independent organisation.

Environmental Management System

Complies with ISO 14001 Standards, certified by an independent organisation.

Health and Safety Management System

Complies with OHSAS 18001 Standards, certified by an independent organisation.



2. Selection and ordering

Withdrawable circuit-breakers

Fixed VD4 circuit-breaker (12 kV)



Circuit-breaker	VD4 12 (1)											
Standards	IEC 62271-100 • VDE 0671; CEI EN 62271-100- File 7642 •											
Rated voltage	Ur [kV]	12										
Rated insulation voltage	Us [kV]	12										
Withstand voltage at 50 Hz	Ud (1 min) [kV]	28										
Impulse withstand voltage	Up [kV]	75										
Rated frequency	fr [Hz]	50-60										
Rated normal current (40 °C)	Ir [A]	630	630	630	1250	1250	1250	1250	1250	1250	1250	
		16	16	16	16	16	16	—	—	—	—	
Rated breaking capacity (rated short-circuit breaking current symmetrical)	Isc [kA]	20	20	20	20	20	20	—	—	—	—	
		25	25	25	25	25	25	—	—	—	—	
		31.5	31.5	31.5	31.5	31.5	31.5	—	—	—	—	
		—	—	—	—	—	—	40	40	—	—	
Rated short-time withstand current (3s)	Ik [kA]	—	—	—	—	—	—	—	50	50	—	
		16	16	16	16	16	16	—	—	—	—	
		20	20	20	20	20	20	—	—	—	—	
		25	25	25	25	25	25	—	—	—	—	
Making capacity	Ip [kA]	31.5	31.5	31.5	31.5	31.5	31.5	—	—	—	—	
		—	—	—	—	—	—	40	40	—	—	
		40	40	40	40	40	40	—	—	—	—	
		50	50	50	50	50	50	—	—	—	—	
Operation sequence	[O - 0.3 s - CO - 15 s - CO]	63	63	63	63	63	63	—	—	—	—	
		80	80	80	80	80	80	—	—	—	—	
		—	—	—	—	—	—	100	100	—	—	
		—	—	—	—	—	—	—	—	125	125	
Opening time	[ms]	33 ... 60										
Arcing time	[ms]	10 ... 15										
Total breaking time	[ms]	43 ... 75										
Closing time	[ms]	60 ... 80										
Maximum overall dimensions		H [mm]	461	461	461	461	461	461	589	589	610	610
		W [mm]	450	570	700	450	570	700	570	700	600	750
		D [mm]	424	424	424	424	424	424	424	424	459	459
		Pole distance P [mm]	150	210	275	150	210	275	210	275	210	275
Weight	[kg]	73	75	79	73	75	79	84	84	146	158	
Standardised table of dimensions	TN	7405	7406	—	7405	7406	—	—	—	—	—	
	1VCD	—	—	000051	—	—	000051	003282	003285	003440	003441	
Operating temperature	[°C]	- 5 ... + 40										
Tropicalization	IEC: 60068-2-30, 60721-2-1	•										
Electromagnetic compatibility	IEC: 62271-1	•										

Provided by Northeast Power Systems, Inc.
 www.nepsi.com

(1) Circuit-breakers up to 1250 A and 31.5 kA have polyamide poles.

•																
•																
12																
12																
28																
75																
50-60																
1600	1600	1600	1600	1600	1600	1600	1600	2000	2000	2000	2000	2500	2500	2500	3150	3150
—	—	—	—	—	—	—	—	—	—	—	—	—	—	—	—	—
20	20	20	—	—	—	—	—	20	20	—	—	20	20	—	20	—
25	25	25	—	—	—	—	—	25	25	—	—	25	25	—	25	—
31.5	31.5	31.5	—	—	—	—	—	31.5	31.5	—	—	31.5	31.5	—	31.5	—
—	—	—	40	40	—	—	—	40	40	—	—	—	40	—	40	—
—	—	—	—	—	50	50	—	—	—	50	50	—	—	50	—	50
—	—	—	—	—	—	—	—	—	—	—	—	—	—	—	—	—
20	20	20	—	—	—	—	—	20	20	—	—	20	20	—	20	—
25	25	25	—	—	—	—	—	25	25	—	—	25	25	—	25	—
31.5	31.5	31.5	—	—	—	—	—	31.5	31.5	—	—	31.5	31.5	—	31.5	—
—	—	—	40	40	—	—	—	40	40	—	—	—	40	—	40	—
—	—	—	—	—	50	50	—	—	—	50	50	—	—	50	—	50
—	—	—	—	—	—	—	—	—	—	—	—	—	—	—	—	—
50	50	50	—	—	—	—	—	50	50	—	—	50	50	—	50	—
63	63	63	—	—	—	—	—	63	63	—	—	63	63	—	63	—
80	80	80	—	—	—	—	—	80	80	—	—	80	80	—	80	—
—	—	—	100	100	—	—	—	100	100	—	—	—	100	—	100	—
—	—	—	—	—	125	125	—	—	—	125	125	—	—	125	—	125
•	•	•	•	•	•	•	•	•	•	•	•	•	•	•	•	—
33 ... 60																
10 ... 15																
43 ... 75																
60 ... 80																
599	599	599	589	589	610	610	599	599	610	610	599	599	610	635	636	
450	570	700	570	700	600	750	570	700	600	750	570	700	750	700	750	
424	424	424	424	424	459	459	424	424	459	459	424	424	459	424	459	
150	210	275	210	275	210	275	210	275	210	275	210	275	275	275	275	
93	98	105	84	84	146	158	98	105	146	158	98	105	163	140	177	
—	7407	7408	—	—	—	—	7407	7408	—	—	7407	7408	—	—	—	
000050	—	—	003282	003285	003440	003441	—	—	003440	003441	—	—	003441	000149	003443	
- 5 ... + 40																
•																
•																

2. Selection and ordering Withdrawable circuit-breakers

Fixed VD4 circuit-breaker (17.5 kV)

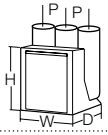

Circuit-breaker	VD4 17 (1)											
Standards	IEC 62271-100 • VDE 0671; CEI EN 62271-100- File 7642 •											
Rated voltage	Ur [kV]	17.5										
Rated insulation voltage	Us [kV]	17.5										
Withstand voltage at 50 Hz	Ud (1 min) [kV]	38										
Impulse withstand voltage	Up [kV]	95										
Rated frequency	fr [Hz]	50-60										
Rated normal current (40 °C)	Ir [A]	630	630	630	1250	1250	1250	1250	1250	1250	1250	
		16	16	16	16	16	16	—	—	—	—	
Rated breaking capacity (rated short-circuit breaking current symmetrical)	Isc [kA]	20	20	20	20	20	20	—	—	—	—	
		25	25	25	25	25	25	—	—	—	—	
		31.5	31.5	31.5	31.5	31.5	31.5	—	—	—	—	
		—	—	—	—	—	—	40	40	—	—	
Rated short-time withstand current (3s)	Ik [kA]	—	—	—	—	—	—	—	50	50	—	
		16	16	16	16	16	16	—	—	—	—	
		20	20	20	20	20	20	—	—	—	—	
		25	25	25	25	25	25	—	—	—	—	
Making capacity	Ip [kA]	31.5	31.5	31.5	31.5	31.5	31.5	—	—	—	—	
		—	—	—	—	—	—	40	40	—	—	
		40	40	40	40	40	40	—	—	—	—	
		50	50	50	50	50	50	—	—	—	—	
Operation sequence	[O - 0.3 s - CO - 15 s - CO]	63	63	63	63	63	63	—	—	—	—	
		80	80	80	80	80	80	—	—	—	—	
Opening time	[ms]	—	—	—	—	—	—	100	100	—	—	
		—	—	—	—	—	—	—	—	125	125	
Arcing time	[ms]	• • • • • • • • • • •										
Total breaking time	[ms]	33 ... 60										
Closing time	[ms]	10 ... 15										
Maximum overall dimensions		H [mm]	461	461	461	461	461	461	589	589	610	610
		W [mm]	450	570	700	450	570	700	570	700	600	750
		D [mm]	424	424	424	424	424	424	424	424	459	459
		Pole distance P [mm]	150	210	275	150	210	275	210	275	210	275
Weight	[kg]	73	75	79	73	75	79	84	84	146	158	
Standardised table of dimensions	TN	7405	7406	—	7405	7406	—	—	—	—	—	
		1VCD	—	—	000051	—	—	000051	003282	003285	003440	003441
Operating temperature	[°C]	- 5 ... + 40										
Tropicalization	IEC: 60068-2-30, 60721-2-1	•										
Electromagnetic compatibility	IEC: 62271-1	•										

Provided by Northeast Power Systems, Inc.
www.nepsi.com

(1) Circuit-breakers up to 1250 A and 31.5 kA have polyamide poles.

•															
•															
17.5															
17.5															
38															
95															
50-60															
1600	1600	1600	1600	1600	1600	1600	2000	2000	2000	2000	2500	2500	2500	3150	3150
—	—	—	—	—	—	—	—	—	—	—	—	—	—	—	—
20	20	—	—	—	—	—	20	20	—	—	20	20	—	20	—
25	25	—	—	—	—	—	25	25	—	—	25	25	—	25	—
31.5	31.5	—	—	—	—	—	31.5	31.5	—	—	31.5	31.5	—	31.5	—
—	—	40	40	—	—	—	40	40	—	—	—	40	—	40	—
—	—	—	—	50	50	—	—	—	50	50	—	—	50	—	50
—	—	—	—	—	—	—	—	—	—	—	—	—	—	—	—
20	20	—	—	—	—	—	20	20	—	—	20	20	—	20	—
25	25	—	—	—	—	—	25	25	—	—	25	25	—	25	—
31.5	31.5	—	—	—	—	—	31.5	31.5	—	—	31.5	31.5	—	31.5	—
—	—	40	40	—	—	—	40	40	—	—	—	40	—	40	—
—	—	—	—	50	50	—	—	—	50	50	—	—	50	—	50
—	—	—	—	—	—	—	—	—	—	—	—	—	—	—	—
50	50	—	—	—	—	—	50	50	—	—	50	50	—	50	—
63	63	—	—	—	—	—	63	63	—	—	63	63	—	63	—
80	80	—	—	—	—	—	80	80	—	—	80	80	—	80	—
—	—	100	100	—	—	—	100	100	—	—	—	100	—	100	—
—	—	—	—	125	125	—	—	—	125	125	—	—	125	—	125
•	•	•	•	•	•	•	•	•	•	•	•	•	•	•	—
33 ... 60															
10 ... 15															
43 ... 75															
60 ... 80															
599	599	589	589	610	610	599	599	610	610	599	599	610	635	636	
570	700	570	700	600	750	570	700	600	750	570	700	750	700	750	
424	424	424	424	459	459	424	424	459	459	424	424	459	424	459	
210	275	210	275	210	275	210	275	210	275	210	275	275	275	275	
98	105	84	84	146	158	98	105	146	158	98	105	163	140	177	
7407	7408	—	—	—	—	7407	7408	—	—	7407	7408	—	—	—	
—	—	003282	003285	003440	003441	—	—	003440	003441	—	—	003441	000149	003443	
- 5 ... + 40															
•															
•															

2. Selection and ordering

Withdrawable circuit-breakers

Fixed VD4 circuit-breaker (24 kV)



Circuit-breaker	VD4 24							
Standards	IEC 62271-100 • VDE 0671; CEI EN 62271-100- File 7642 •							
Rated voltage	Ur [kV]	24						
Rated insulation voltage	Us [kV]	24						
Withstand voltage at 50 Hz	Ud (1 min) [kV]	50						
Impulse withstand voltage	Up [kV]	125						
Rated frequency	fr [Hz]	50-60						
Rated normal current (40 °C)	Ir [A]	630	630	1250	1250	1600	2000	2500
		16	16	16	16	16	16	-
Rated breaking capacity (rated short-circuit breaking current symmetrical)	Isc [kA]	20	20	20	20	20	20	-
		25	25	25	25	25	25	25
		-	-	31.5	-	31.5	31.5	31.5
Rated short-time withstand current (3s)	Ik [kA]	16	16	16	16	16	16	-
		20	20	20	20	20	20	-
		25	25	25	25	25	25	25
Making capacity	Ip [kA]	-	-	31.5	-	31.5	31.5	31.5
		40	40	40	40	40	40	-
		50	50	50	50	50	50	-
Operation sequence	[O - 0.3 s - CO - 15 s - CO]	63	63	63	63	63	63	63
		-	-	80	-	80	80	80
Opening time	[ms]	33 ... 60						
Arcing time	[ms]	10 ... 15						
Total breaking time	[ms]	43 ... 75						
Closing time	[ms]	60 ... 80						
Maximum overall dimensions	H [mm]	631	631	631	631	642	642	642
	W [mm]	570	700	570	700	700	700	700
	D [mm]	424	424	424	424	424	424	424
	Pole distance P [mm]	210	275	210	275	275	275	275
Weight	[kg]	100	104	100/106 ⁽¹⁾	104	110	110	110
		TN	7409	7410	7409	7410	7411	7411
Standardised table of dimensions	1VCD	-	-	000172 ⁽¹⁾	-	-	-	-
		Operating temperature [°C] - 5 ... + 40						
Tropicalization	IEC: 60068-2-30, 60721-2-1 •							
Electromagnetic compatibility	IEC: 62271-1 •							

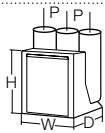

(1) 31.5 kA version.

Fixed VD4 circuit-breaker (36 kV)



Circuit-breaker		VD4 36			
Standards	IEC 62271-100	•			
	VDE 0671; CEI EN 62271-100- File 7642	•			
Rated voltage	Ur [kV]	36			
Rated insulation voltage	Us [kV]	36			
Withstand voltage at 50 Hz	Ud (1 min) [kV]	70			
Impulse withstand voltage	Up [kV]	170			
Rated frequency	fr [Hz]	50-60			
Rated normal current (40 °C)	Ir [A]	1250	1600	2000	2500 (*)
Rated breaking capacity (rated short-circuit breaking current symmetrical)	Isc [kA]	—	—	—	—
		31,5	31,5	31,5	31,5
Rated short-time withstand current (3s)	Ik [kA]	—	—	—	—
		31,5	31,5	31,5	31,5
Making capacity	Ip [kA]	—	—	—	—
		80	80	80	80
Operation sequence	[O - 0.3 s - CO - 15 s - CO]	•			
Opening time	[ms]	35 ... 60			
Arcing time	[ms]	10 ... 15			
Total breaking time	[ms]	45 ... 75			
Closing time	[ms]	60 ... 80			
Maximum overall dimensions	H [mm]	564	564	564	—
	W [mm]	778	778	778	—
	D [mm]	468	468	468	—
	Pole distance P [mm]	275	275	275	—
Weight	[kg]	150	150	170	—
Standardised table of dimensions	TN	1VYN300901-LT	1VYN300901-LT	1VYN300901-LT	—
Operating temperature	[°C]	- 5 ... + 40			
Tropicalization	IEC: 60068-2-30, 60721-2-1	•			
Electromagnetic compatibility	IEC: 62271-1	•			

(*) Contact ABB.

2. Selection and ordering

Withdrawable circuit-breakers

Types of fixed version circuit-breakers available

Complete the circuit-breaker selected with the optional accessories indicated on the following pages.

VD4 fixed circuit-breaker without bottom and top terminals (12 kV)

Ur	Isc	Rated uninterrupted current (40°C) [A]											Circuit-breaker type
		H=461			H=589		H=599			H=610		H=636	
kV	kA	D=424			D=424		D=424			D=459		D=459	
		u/l=205			u/l=310		u/l=310			u/l=310		u/l=310	
		l/g=217.5			l/g=238		l/g=237.5			l/g=237		l/g=237	
		P=150	P=210	P=275	P=210	P=275	P=150	P=210	P=275	P=210	P=275	P=275	
		W=450	W=570	W=700	W=570	W=700	W=450	W=570	W=700	W=600	W=750	W=750	
12	16	630											VD4 12.06.16 p150
	20	630											VD4 12.06.20 p150
	25	630											VD4 12.06.25 p150
	31.5	630											VD4 12.06.32 p150
	16	1250											VD4 12.12.16 p150
	20	1250											VD4 12.12.20 p150
	25	1250											VD4 12.12.25 p150
	31.5	1250											VD4 12.12.32 p150
	20							1600					VD4 12.16.20 p150
	25							1600					VD4 12.16.25 p150
	31.5							1600					VD4 12.16.32 p150
	16		630										VD4 12.06.16 p210
	20		630										VD4 12.06.20 p210
	25		630										VD4 12.06.25 p210
	31.5		630										VD4 12.06.32 p210
	16		1250										VD4 12.12.16 p210
	20		1250										VD4 12.12.20 p210
	25		1250										VD4 12.12.25 p210
	31.5		1250										VD4 12.12.32 p210
	40				1250								VD4 12.12.40 p210
	50									1250			VD4 12.12.50 p210
	20								1600				VD4 12.16.20 p210
	25								1600				VD4 12.16.25 p210
	31.5								1600				VD4 12.16.32 p210
	40					1600							VD4 12.16.40 p210
	50									1600			VD4 12.16.50 p210
	20								2000				VD4 12.20.20 p210
	25								2000				VD4 12.20.25 p210
	31.5								2000				VD4 12.20.32 p210
	40								2000				VD4 12.20.40 p210
	50									2000			VD4 12.20.50 p210
20									2500			VD4 12.25.20 p210	
25									2500			VD4 12.25.25 p210	
31.5									2500			VD4 12.25.32 p210	

H = Height of the circuit-breaker.

W = Width of the circuit-breaker.

D = Depth of the circuit-breaker.

u/l = Distance between bottom and top terminal.

l/g = Distance between the bottom terminal and the resting surface of the circuit-breaker.

P = Pole horizontal centre distance.

VD4 fixed circuit-breaker without bottom and top terminals (12 kV)

Ur	Isc	Rated uninterrupted current (40°C) [A]											Circuit-breaker type
		H=461			H=589		H=599		H=610		H=636		
kV	kA	D=424			D=424		D=424		D=459		D=459		
		u/l=205			u/l=310		u/l=310		u/l=310		u/l=310		
		I/g=217.5			I/g=238		I/g=237.5		I/g=237		I/g=237		
		P=150	P=210	P=275	P=210	P=275	P=150	P=210	P=275	P=210	P=275	P=275	
		W=450	W=570	W=700	W=570	W=700	W=450	W=570	W=700	W=600	W=750	W=750	
12	16			630								VD4 12.06.16 p275	
	20			630								VD4 12.06.20 p275	
	25			630								VD4 12.06.25 p275	
	31.5			630								VD4 12.06.32 p275	
	16			1250								VD4 12.12.16 p275	
	20			1250								VD4 12.12.20 p275	
	25			1250								VD4 12.12.25 p275	
	31.5			1250								VD4 12.12.32 p275	
	40					1250						VD4 12.12.40 p275	
	50									1250		VD4 12.12.50 p275	
	20								1600			VD4 12.16.20 p275	
	25								1600			VD4 12.16.25 p275	
	31.5								1600			VD4 12.16.32 p275	
	40					1600						VD4 12.16.40 p275	
	50									1600		VD4 12.16.50 p275	
	20								2000			VD4 12.20.20 p275	
	25								2000			VD4 12.20.25 p275	
	31.5								2000			VD4 12.20.32 p275	
	40								2000			VD4 12.20.40 p275	
	50									2000		VD4 12.20.50 p275	
	20								2500			VD4 12.25.20 p275	
	25								2500			VD4 12.25.25 p275	
	31.5								2500			VD4 12.25.32 p275	
	40								2500			VD4 12.25.40 p275	
	50									2500		VD4 12.25.50 p275	
	20										3150	VD4 12.32.20 p275	
	25										3150	VD4 12.32.25 p275	
	31.5										3150	VD4 12.32.32 p275	
40										3150	VD4 12.32.40 p275		
50										3150	VD4 12.32.50 p275		

- H = Height of the circuit-breaker.
- W = Width of the circuit-breaker.
- D = Depth of the circuit-breaker.
- u/l = Distance between bottom and top terminal.
- I/g = Distance between the bottom terminal and the resting surface of the circuit-breaker.
- P = Pole horizontal centre distance.

2. Selection and ordering Withdrawable circuit-breakers

VD4 fixed circuit-breaker without bottom and top terminals (17.5 kV)

Ur	Isc	Rated uninterrupted current (40 °C) [A]											Circuit-breaker type						
kV	kA	H=461			H=589			H=599			H=610			H=635					
		D=424			D=424			D=424			D=459			D=459					
		u/l=205			u/l=310			u/l=310			u/l=310			u/l=310					
		l/g=217.5			l/g=238			l/g=237.5			l/g=237			l/g=237.5					
		P=150	P=210	P=275	P=210	P=275	P=150	P=210	P=275	P=210	P=275	P=275							
		W=450	W=570	W=700	W=570	W=700	W=450	W=570	W=700	W=600	W=750	W=750							
17.5	16	630											VD4 17.06.16 p150						
	20	630											VD4 17.06.20 p150						
	25	630											VD4 17.06.25 p150						
	31.5	630											VD4 17.06.32 p150						
	16	1250											VD4 17.12.16 p150						
	20	1250											VD4 17.12.20 p150						
	25	1250											VD4 17.12.25 p150						
	31.5	1250											VD4 17.12.32 p150						
	16		630											VD4 17.06.16 p210					
	20		630											VD4 17.06.20 p210					
	25		630											VD4 17.06.25 p210					
	31.5		630											VD4 17.06.32 p210					
	16		1250											VD4 17.12.16 p210					
	20		1250											VD4 17.12.20 p210					
	25		1250											VD4 17.12.25 p210					
	31.5		1250											VD4 17.12.32 p210					
	40			1250											VD4 17.12.40 p210				
	50				1250											VD4 17.12.50 p210			
	20					1600											VD4 17.16.20 p210		
	25					1600											VD4 17.16.25 p210		
	31.5					1600											VD4 17.16.32 p210		
	40			1600											VD4 17.16.40 p210				
	50						1600											VD4 17.16.50 p210	
	20						2000											VD4 17.20.20 p210	
	25						2000											VD4 17.20.25 p210	
	31.5						2000											VD4 17.20.32 p210	
	40						2000											VD4 17.20.40 p210	
	50							2000											VD4 17.20.50 p210
	20							2500											VD4 17.25.20 p210
	25							2500											VD4 17.25.25 p210
31.5							2500											VD4 17.25.32 p210	

H = Height of the circuit-breaker.

W = Width of the circuit-breaker.

D = Depth of the circuit-breaker.

u/l = Distance between bottom and top terminal.

l/g = Distance between the bottom terminal and the resting surface of the circuit-breaker.

P = Pole horizontal centre distance.

VD4 fixed circuit-breaker without bottom and top terminals (17.5 kV)

Ur	Isc	Rated uninterrupted current (40 °C) [A]											Circuit-breaker type
		H=461			H=589		H=599		H=610		H=635		
kV	kA	D=424			D=424		D=424		D=459		D=459		
		u/l=205			u/l=310		u/l=310		u/l=310		u/l=310		
		I/g=217.5			I/g=238		I/g=237.5		I/g=237		I/g=237.5		
		P=150	P=210	P=275	P=210	P=275	P=150	P=210	P=275	P=210	P=275	P=275	
		W=450	W=570	W=700	W=570	W=700	W=450	W=570	W=700	W=600	W=750	W=750	
17.5	16			630									VD4 17.06.16 p275
	20			630									VD4 17.06.20 p275
	25			630									VD4 17.06.25 p275
	31.5			630									VD4 17.06.32 p275
	16			1250									VD4 17.12.16 p275
	20			1250									VD4 17.12.20 p275
	25			1250									VD4 17.12.25 p275
	31.5			1250									VD4 17.12.32 p275
	40					1250							VD4 17.12.40 p275
	50									1250			VD4 17.12.50 p275
	20								1600				VD4 17.16.20 p275
	25								1600				VD4 17.16.25 p275
	31.5								1600				VD4 17.16.32 p275
	40					1600							VD4 17.16.40 p275
	50									1600			VD4 17.16.50 p275
	20								2000				VD4 17.20.20 p275
	25								2000				VD4 17.20.25 p275
	31.5								2000				VD4 17.20.32 p275
	40								2000				VD4 17.20.40 p275
	50									2000			VD4 17.20.50 p275
	20								2500				VD4 17.25.20 p275
	25								2500				VD4 17.25.25 p275
	31.5								2500				VD4 17.25.32 p275
	40								2500				VD4 17.25.40 p275
	50									2500			VD4 17.25.50 p275
	20										3150		VD4 17.32.20 p275
	25										3150		VD4 17.32.25 p275
	31.5										3150		VD4 17.32.32 p275
	40										3150		VD4 17.32.40 p275
	50										3150		VD4 17.32.50 p275

- H = Height of the circuit-breaker.
- W = Width of the circuit-breaker.
- D = Depth of the circuit-breaker.
- u/l = Distance between bottom and top terminal.
- I/g = Distance between the bottom terminal and the resting surface of the circuit-breaker.
- P = Pole horizontal centre distance.

2. Selection and ordering

Withdrawable circuit-breakers

VD4 fixed circuit-breaker without bottom and top terminals (24 kV)

Ur	Isc	Rated uninterrupted current (40 °C) [A]			
kV	kA	H=631		H=642	
		D=424		D=424	
		u/l=310		u/l=310	
		l/g=282.5		l/g=282.5	
		P=210	P=275	P=275	
		W=570	W=700	W=700	
				Circuit-breaker type	
24	16	630		VD4 24.06.16 p210	
	20	630		VD4 24.06.20 p210	
	25	630		VD4 24.06.25 p210	
	16	1250		VD4 24.12.16 p210	
	20	1250		VD4 24.12.20 p210	
	25	1250		VD4 24.12.25 p210	
	31.5	1250		VD4 24.12.32 p210	
	16		630	VD4 24.06.16 p275	
	20		630	VD4 24.06.20 p275	
	25		630	VD4 24.06.25 p275	
	16		1250	VD4 24.12.16 p275	
	20		1250	VD4 24.12.20 p275	
	25		1250	VD4 24.12.25 p275	
	16			1600	VD4 24.16.16 p275
	20			1600	VD4 24.16.20 p275
	25			1600	VD4 24.16.25 p275
	31.5			1600	VD4 24.16.32 p275
	16			2000	VD4 24.20.16 p275
	20			2000	VD4 24.20.20 p275
	25			2000	VD4 24.20.25 p275
	31.5			2000	VD4 24.20.32 p275
	25			2500	VD4 24.25.25 p275
	31.5			2500	VD4 24.25.32 p275

H = Height of the circuit-breaker.

W = Width of the circuit-breaker.

D = Depth of the circuit-breaker.

u/l = Distance between bottom and top terminal.

l/g = Distance between the bottom terminal and the resting surface of the circuit-breaker.

P = Pole horizontal centre distance.

VD4 fixed circuit-breaker without bottom and top terminals (36 kV)

Ur	Isc	Rated uninterrupted current (40 °C) [A]	
kV	kA	H=876	Circuit-breaker type
		D=478.5	
		u/l=328	
		l/g=428.5	
		P=275	
		W=786	
36	31.5	1250 A	VD4 36.12.32 p275
		1600 A	VD4 36.16.32 p275
		2000 A	VD4 36.20.32 p275
		2500 A (*)	VD4 36.25.32 p275

H = Height of the circuit-breaker.

W = Width of the circuit-breaker.

D = Depth of the circuit-breaker.

u/l = Distance between bottom and top terminal.

l/g = Distance between the bottom terminal and the resting surface of the circuit-breaker.

P = Pole horizontal centre distance.

(*) = Contact ABB.

Standard fittings of fixed circuit-breakers

The basic versions of the fixed circuit-breakers are three-pole and fitted with:

- EL type manual operating mechanism
 - mechanical signalling device for closing springs charged/discharged
 - mechanical signalling device for circuit-breaker open/closed
 - closing pushbutton, opening pushbutton and operation counter
 - set of ten auxiliary circuit-breaker break/make contacts
- Note: with the group of ten auxiliary contacts supplied as standard and the maximum number of electrical applications, three break contacts (signalling circuit-breaker open) and five make contacts (signalling circuit-breaker closed) are available.
- lever for manually charging the closing springs
 - auxiliary circuit support terminal board.



VD4 - up to 24 kV



VD4 - 36 kV

2. Selection and ordering

Withdrawable circuit-breakers

Withdrawable version circuit-breakers for UniGear ZS1 switchgear (12 kV)

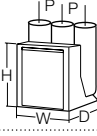

Circuit-breaker		VD4/P 12 ⁽³⁾							
Standards	IEC 62271-100	•							
	VDE 0671; CEI EN 62271-100- File 7642	•							
Rated voltage	Ur [kV]	12							
Rated insulation voltage	Us [kV]	12							
Withstand voltage at 50 Hz	Ud (1 min) [kV]	28							
Impulse withstand voltage	Up [kV]	75							
Rated frequency	fr [Hz]	50-60							
Rated normal current (40 °C) ⁽¹⁾	Ir [A]	630	1250	1250	1250	1250	1600	1600	
		16	16	—	—	—	—	—	
Rated breaking capacity (rated short-circuit breaking current symmetrical)	Isc [kA]	20	20	—	—	—	20	20	
		25	25	—	—	—	25	25	
		31.5	31.5	—	—	—	31.5	31.5	
		—	—	40	40	—	—	—	
		—	—	—	—	50	—	—	
Rated short-time withstand current (3s)	Ik [kA]	16	16	—	—	—	—	—	
		20	20	—	—	—	20	20	
		25	25	—	—	—	25	25	
		31.5	31.5	—	—	—	31.5	31.5	
		—	—	40	40	—	—	—	
Making capacity	Ip [kA]	—	—	—	—	50	—	—	
		40	40	—	—	—	—	—	
		50	50	—	—	—	50	50	
		63	63	—	—	—	63	63	
		80	80	—	—	—	80	80	
Operation sequence	[O - 0.3 s - CO - 15 s - CO]	•	•	•	•	•	•	•	
		•	•	•	•	•	•	•	
Opening time	[ms]	33 ... 60							
Arcing time	[ms]	10 ... 15							
Total breaking time	[ms]	43 ... 75							
Closing time	[ms]	60 ... 80							
Maximum overall dimensions		H [mm]	628	628	691	691	691	691	691
		W [mm]	503	503	653	853	681	653	853
		D [mm]	662	662	641	642	643	642	642
		Pole distance P [mm]	150	150	210	275	210	210	275
		Weight	[kg]	116	116	174	176	180	160
Standardised table of dimensions	TN	7412	7412	—	—	—	7415	7416	
	1VCD	—	—	003284	003286	003444	—	—	
Operating temperature	[°C]	- 5 ... + 40							
Tropicalization	IEC: 60068-2-30, 60721-2-1	•							
Electromagnetic compatibility	IEC: 62271-1	•							

Provided by Northeast Power Systems, Inc.
www.nepsi.com

(1) Rated current guaranteed with circuit-breaker installed in UniGear ZS1 switchgear and with 40 °C ambient temperature.

(2) Up to 4000 A with forced ventilation.

(3) Circuit-breakers up to 1250 A and 31.5 kA have polyamide poles.

•												
•												
12												
12												
28												
75												
50-60												
1600	1600	1600	1600	2000	2000	2000	2000	2500	2500	3150 ⁽²⁾	3150 ⁽²⁾	
—	—	—	—	—	—	—	—	—	—	—	—	—
—	—	—	—	20	20	—	—	20	—	20	—	—
—	—	—	—	25	25	—	—	25	—	25	—	—
—	—	—	—	31.5	31.5	—	—	31.5	—	31.5	—	—
40	40	—	—	40	40	—	—	40	—	40	—	—
—	—	50	50	—	—	50	50	—	50	—	50	—
—	—	—	—	—	—	—	—	—	—	—	—	—
—	—	—	—	20	20	—	—	20	—	20	—	—
—	—	—	—	25	25	—	—	25	—	25	—	—
—	—	—	—	31.5	31.5	—	—	31.5	—	31.5	—	—
40	40	—	—	40	40	—	—	40	—	40	—	—
—	—	50	50	—	—	50	50	—	50	—	50	—
—	—	—	—	—	—	—	—	—	—	—	—	—
—	—	—	—	50	50	—	—	50	—	50	—	—
—	—	—	—	63	63	—	—	63	—	63	—	—
—	—	—	—	80	80	—	—	80	—	80	—	—
100	100	—	—	100	100	—	—	100	—	100	—	—
—	—	125	125	—	—	125	125	—	125	—	125	—
•	•	•	•	•	•	•	•	•	•	•	•	•
33 ... 60												
10 ... 15												
43 ... 75												
60 ... 80												
691	691	691	691	691	691	691	691	691	691	730	742	
653	853	681	853	653	853	681	853	853	853	853	853	853
641	642	643	643	642	642	643	643	640	643	640	643	643
210	275	210	275	210	275	210	275	275	275	275	275	275
174	176	180	193	160	166	190	205	186	225	221	240	
—	—	—	—	7415	7416	—	—	7417	—	—	—	—
003284	003286	003444	003445	—	—	003444	003445	—	003446	000153	003447	
- 5 ... + 40												
•												
•												

2. Selection and ordering

Withdrawable circuit-breakers

Withdrawable version circuit-breakers
for UniGear ZS1 switchgear (17.5 kV)



Circuit-breaker	VD4/P 17 ⁽³⁾							
Standards	IEC 62271-100	•						
	VDE 0671; CEI EN 62271-100- File 7642	•						
Rated voltage	Ur [kV]	17.5						
Rated insulation voltage	Us [kV]	17.5						
Withstand voltage at 50 Hz	Ud (1 min) [kV]	38						
Impulse withstand voltage	Up [kV]	95						
Rated frequency	fr [Hz]	50-60						
Rated normal current (40 °C) ⁽¹⁾	Ir [A]	630	1250	1250	1250	1250	1600	1600
		16	16	—	—	—	—	—
Rated breaking capacity (rated short-circuit breaking current symmetrical)	Isc [kA]	20	20	—	—	—	20	20
		25	25	—	—	—	25	25
		31.5	31.5	—	—	—	31.5	31.5
		—	—	40	40	—	—	—
		—	—	—	—	50	—	—
Rated short-time withstand current (3s)	Ik [kA]	16	16	—	—	—	—	—
		20	20	—	—	—	20	20
		25	25	—	—	—	25	25
		31.5	31.5	—	—	—	31.5	31.5
		—	—	40	40	—	—	—
Making capacity	Ip [kA]	—	—	—	—	50	—	—
		40	40	—	—	—	—	—
		50	50	—	—	—	50	50
		63	63	—	—	—	63	63
		80	80	—	—	—	80	80
Operation sequence	[O - 0.3 s - CO - 15 s - CO]	•	•	•	•	•	•	•
Opening time	[ms]	33 ... 60						
Arcing time	[ms]	10 ... 15						
Total breaking time	[ms]	43 ... 75						
Closing time	[ms]	60 ... 80						
Maximum overall dimensions	H [mm]	632	632	691	691	691	691	691
	W [mm]	503	503	653	853	681	653	853
	D [mm]	664	664	641	642	643	642	642
	Pole distance P [mm]	150	150	210	275	210	210	275
Weight	[kg]	116	116	174	176	180	160	166
Standardised table of dimensions	TN	7412	7412	—	—	—	7415	7416
	1VCD	—	—	003284	003286	003444	—	—
Operating temperature	[°C]	- 5 ... + 40						
Tropicalization	IEC: 60068-2-30, 60721-2-1	•						
Electromagnetic compatibility	IEC: 62271-1	•						

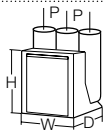

Provided by Northeast Power Systems, Inc.
www.nepsi.com

(1) Rated current guaranteed with circuit-breaker installed in UniGear ZS1 switchgear and with 40 °C ambient temperature.

(2) Up to 4000 A with forced ventilation.

(3) Circuit-breakers up to 1250 A and 31.5 kA have polyamide poles.

•												
•												
17,5												
17,5												
38												
95												
50-60												
1600	1600	1600	1600	2000	2000	2000	2000	2500	2500	3150 ⁽²⁾	3150 ⁽²⁾	
—	—	—	—	—	—	—	—	—	—	—	—	—
—	—	—	—	20	20	—	—	20	—	20	—	—
—	—	—	—	25	25	—	—	25	—	25	—	—
—	—	—	—	31,5	31,5	—	—	31,5	—	31,5	—	—
40	40	—	—	40	40	—	—	40	—	40	—	—
—	—	50	50	—	—	50	50	—	50	—	50	—
—	—	—	—	—	—	—	—	—	—	—	—	—
—	—	—	—	20	20	—	—	20	—	20	—	—
—	—	—	—	25	25	—	—	25	—	25	—	—
—	—	—	—	31,5	31,5	—	—	31,5	—	31,5	—	—
40	40	—	—	40	40	—	—	40	—	40	—	—
—	—	50	50	—	—	50	50	—	50	—	50	—
—	—	—	—	—	—	—	—	—	—	—	—	—
—	—	—	—	50	50	—	—	50	—	50	—	—
—	—	—	—	63	63	—	—	63	—	63	—	—
—	—	—	—	80	80	—	—	80	—	80	—	—
100	100	—	—	100	100	—	—	100	—	100	—	—
—	—	125	125	—	—	125	125	—	125	—	125	—
•	•	•	•	•	•	•	•	•	•	•	•	•
33 ... 60												
10 ... 15												
43 ... 75												
60 ... 80												
691	691	691	691	691	691	691	691	691	691	730	742	
653	853	681	853	653	853	681	853	853	853	853	853	853
641	642	643	643	642	642	643	643	640	643	640	643	643
210	275	210	275	210	275	210	275	275	275	275	275	275
174	176	180	193	160	166	190	205	186	225	221	240	
—	—	—	—	7415	7416	—	—	7417	—	—	—	—
003284	003286	003444	003445	—	—	003444	003445	—	003446	000153	003447	
- 5 ... + 40												
•												
•												

2. Selection and ordering

Withdrawable circuit-breakers

Withdrawable version circuit-breakers
for UniGear ZS1 switchgear (24 kV)

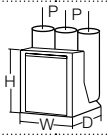

Circuit-breaker		VD4/P 24								
Standards	IEC 62271-100 • VDE 0671; CEI EN 62271-100- File 7642 •									
Rated voltage	Ur [kV]	24								
Rated insulation voltage	Us [kV]	24								
Withstand voltage at 50 Hz	Ud (1 min) [kV]	50								
Impulse withstand voltage	Up [kV]	125								
Rated frequency	fr [Hz]	50-60								
Rated normal current (40 °C) ⁽¹⁾	Ir [A]	630	630	1250	1250	1600	2000	2500 ⁽²⁾	3150 ⁽³⁾	
		16	16	16	16	16	16	16	-	
Rated breaking capacity (rated short-circuit breaking current symmetrical)	Isc [kA]	20	20	20	20	20	20	20	-	
		25	25	25	25	25	25	25	-	
		-	-	31.5	-	31.5	31.5	31.5	31.5	
Rated short-time withstand current (3s)	Ik [kA]	16	16	16	16	16	16	16	-	
		20	20	20	20	20	20	20	-	
		25	25	25	25	25	25	25	-	
Making capacity	Ip [kA]	-	-	31.5	-	31.5	31.5	31.5	31.5	
		40	40	40	40	40	40	40	-	
		50	50	50	50	50	50	50	-	
Operation sequence	[O - 0.3 s - CO - 15 s - CO]	63	63	63	63	63	63	63	-	
		-	-	80	-	80	80	80	80	
Opening time	[ms]	33 ... 60								
Arcing time	[ms]	10 ... 15								
Total breaking time	[ms]	43 ... 75								
Closing time	[ms]	60 ... 80								
Maximum overall dimensions		H [mm]	794	794	794	794	838	838	838	838
		W [mm]	653	853	653	853	853	853	853	853
		D [mm]	802	802	802	802	790	790	790	790
		Pole distance P [mm]	210	275	210	275	275	275	275	275
Weight	[kg]	140	148	140/146 ⁽⁴⁾	148	228	228	228	277	
Standardised table of dimensions	TN	7413	7414	7413	7414	7418	7418	7418	-	
	1VCD	-	-	000173 ⁽⁴⁾	-	-	-	-	000177	
Operating temperature	[°C]	- 5 ... + 40								
Tropicalization	IEC: 60068-2-30, 60721-2-1 •									
Electromagnetic compatibility	IEC: 62271-1 •									

- (1) Rated current guaranteed with circuit-breaker installed in UniGear ZS1 switchgear and with 40 °C ambient temperature.
(2) 2300 A rated current guaranteed with natural ventilation; 2500 A rated current guaranteed with forced ventilation.
(3) 2700 A rated current guaranteed with natural ventilation; 3150 A rated current guaranteed with forced ventilation.
(4) 31.5 kA version.

General characteristics of withdrawable circuit-breakers for UniGear ZS2 and PowerCube modules (36 kV)



Circuit-breaker		VD4/W 36			
Standards	IEC 62271-100	•			
	VDE 0671; CEI EN 62271-100- File 7642	•			
Rated voltage	Ur [kV]	36			
Rated insulation voltage	Us [kV]	36			
Withstand voltage at 50 Hz	Ud (1 min) [kV]	70			
Impulse withstand voltage	Up [kV]	170			
Rated frequency	fr [Hz]	50-60			
Rated normal current (40 °C) ⁽¹⁾	Ir [A]	1250	1600	2000	2500 ^(*)
Rated breaking capacity (rated short-circuit breaking current symmetrical)	Isc [kA]	—	—	—	—
		31,5	31,5	31,5	31,5
Rated short-time withstand current (3s)	Ik [kA]	—	—	—	—
		31,5	31,5	31,5	31,5
Making capacity	Ip [kA]	—	—	—	—
		80	80	80	80
Operation sequence	[O - 0.3 s - CO - 15 s - CO]	•			
Opening time	[ms]	33 ... 60			
Arcing time	[ms]	10 ... 15			
Total breaking time	[ms]	45 ... 75			
Closing time	[ms]	60 ... 80			
Maximum overall dimensions	H [mm]	973	973	973	973
	W [mm]	842	842	842	842
	D [mm]	788	788	788	788
	Pole distance P [mm]	275	275	275	275
Weight	[kg]	230	230	230	—
Standardised table of dimensions	TN	1VYN300901-KG	1VYN300901-KG	1VYN300901-KG	—
Operating temperature	[°C]	- 5 ... + 40			
Tropicalization	IEC: 60068-2-30, 60721-2-1	•			
Electromagnetic compatibility	IEC: 62271-1	•			

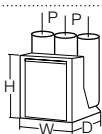

(*) Ask ABB

2. Selection and ordering

Withdrawable circuit-breakers

Types of withdrawable version circuit-breakers available for UniGear ZS1 switchgear

Complete the circuit-breaker selected with the optional accessories indicated on the following pages.

VD4 (12 kV) withdrawable circuit-breaker

Ur	Isc	Rated uninterrupted current (40 °C) [A]					Circuit-breaker type
		W=650	W=800	W=1000	W=1000	W=1000	
kV	kA	P=150	P=210	P=275	P=275	P=275	
		u/l=205	u/l=310	u/l=310	u/l=310	u/l=310	
		ø=35	ø=79	ø=79	ø=109	ø=109	
12	16	630					VD4/P 12.06.16 p150
	20	630					VD4/P 12.06.20 p150
	25	630					VD4/P 12.06.25 p150
	31.5	630					VD4/P 12.06.32 p150
	16	1250					VD4/P 12.12.16 p150
	20	1250					VD4/P 12.12.20 p150
	25	1250					VD4/P 12.12.25 p150
	31.5	1250					VD4/P 12.12.32 p150
	40		1250				VD4/P 12.12.40 p210
	50		1250				VD4/P 12.12.50 p210
	20		1600				VD4/P 12.16.20 p210
	25		1600				VD4/P 12.16.25 p210
	31.5		1600				VD4/P 12.16.32 p210
	40		1600				VD4/P 12.16.40 p210
	50		1600				VD4/P 12.16.50 p210
	20		2000				VD4/P 12.20.20 p210
	25		2000				VD4/P 12.20.25 p210
	31.5		2000				VD4/P 12.20.32 p210
	40		2000				VD4/P 12.20.40 p210
	50		2000				VD4/P 12.20.50 p210
	40			1250			VD4/P 12.12.40 p275
	20			1600			VD4/P 12.16.20 p275
	25			1600			VD4/P 12.16.25 p275
	31.5			1600			VD4/P 12.16.32 p275
	40			1600			VD4/P 12.16.40 p275
	50			1600			VD4/P 12.16.50 p275
	20			2000			VD4/P 12.20.20 p275
	25			2000			VD4/P 12.20.25 p275
	31.5			2000			VD4/P 12.20.32 p275
	40			2000			VD4/P 12.20.40 p275
	50			2000			VD4/P 12.20.50 p275

W = Width of the circuit-breaker.
P = Pole horizontal centre distance.
u/l = Distance between bottom and top terminal.
ø = Diameter of the isolating contact.

VD4 (12 kV) withdrawable circuit-breaker

Ur	Isc	Rated uninterrupted current (40 °C) [A]					Circuit-breaker type
		W=650	W=800	W=1000	W=1000	W=1000	
kV	kA	P=150	P=210	P=275	P=275	P=275	
		u/l=205	u/l=310	u/l=310	u/l=310	u/l=310	
		ø=35	ø=79	ø=79	ø=109	ø=109	
12	20				2500		VD4/P 12.25.20 p275
	25				2500		VD4/P 12.25.25 p275
	31,5				2500		VD4/P 12.25.32 p275
	40				2500		VD4/P 12.25.40 p275
	50				2500		VD4/P 12.25.50 p275
	20					3150 ⁽¹⁾	VD4/P 12.32.20 p275
	25					3150 ⁽¹⁾	VD4/P 12.32.25 p275
	31,5					3150 ⁽¹⁾	VD4/P 12.32.32 p275
	40					3150 ⁽¹⁾	VD4/P 12.32.40 p275
	50					3150 ⁽¹⁾	VD4/P 12.32.50 p275

W = Width of the circuit-breaker.
P = Pole horizontal centre distance.
u/l = Distance between bottom and top terminal.
ø = Diameter of the isolating contact.
(1) Up to 4000 A with forced ventilation.

2. Selection and ordering

Withdrawable circuit-breakers

VD4 (17.5 kV) withdrawable circuit-breaker for UniGear ZS1 switchboard

Ur	Isc	Rated uninterrupted current (40 °C) [A]					Circuit-breaker type
		W=650	W=800	W=1000	W=1000	W=1000	
kV	kA	P=150	P=210	P=275	P=275	P=275	
		u/l=205	u/l=310	u/l=310	u/l=310	u/l=310	
		ø=35	ø=79	ø=79	ø=109	ø=109	
	16	630					VD4/P 17.06.16 p150
	20	630					VD4/P 17.06.20 p150
	25	630					VD4/P 17.06.25 p150
	31.5	630					VD4/P 17.06.32 p150
	16	1250					VD4/P 17.12.16 p150
	20	1250					VD4/P 17.12.20 p150
	25	1250					VD4/P 17.12.25 p150
	31.5	1250					VD4/P 17.12.32 p150
	40		1250				VD4/P 17.12.40 p210
	50		1250				VD4/P 17.12.50 p210
	20		1600				VD4/P 17.16.20 p210
	25		1600				VD4/P 17.16.25 p210
	31.5		1600				VD4/P 17.16.32 p210
	40		1600				VD4/P 17.16.40 p210
	50		1600				VD4/P 17.16.50 p210
17.5	20		2000				VD4/P 17.20.20 p210
	25		2000				VD4/P 17.20.25 p210
	31.5		2000				VD4/P 17.20.32 p210
	40		2000				VD4/P 17.20.40 p210
	50		2000				VD4/P 17.20.50 p210
	40			1250			VD4/P 17.12.40 p275
	20			1600			VD4/P 17.16.20 p275
	25			1600			VD4/P 17.16.25 p275
	31.5			1600			VD4/P 17.16.32 p275
	40			1600			VD4/P 17.16.40 p275
	50			1600			VD4/P 17.16.50 p275
	20			2000			VD4/P 17.20.20 p275
	25			2000			VD4/P 17.20.25 p275
	31.5			2000			VD4/P 17.20.32 p275
	40			2000			VD4/P 17.20.40 p275
	50			2000			VD4/P 17.20.50 p275

W = Width of the circuit-breaker.
P = Pole horizontal centre distance.
u/l = Distance between bottom and top terminal.
ø = Diameter of the isolating contact.

VD4 (17.5 kV) withdrawable circuit-breaker for UniGear ZS1 switchboard

Ur	Isc	Rated uninterrupted current (40 °C) [A]					Circuit-breaker type
		W=650	W=800	W=1000	W=1000	W=1000	
kV	kA	P=150	P=210	P=275	P=275	P=275	
		u/l=205	u/l=310	u/l=310	u/l=310	u/l=310	
		ø=35	ø=79	ø=79	ø=109	ø=109	
17.5	20				2500		VD4/P 17.25.20 p275
	25				2500		VD4/P 17.25.25 p275
	31.5				2500		VD4/P 17.25.32 p275
	40				2500		VD4/P 17.25.40 p275
	50				2500		VD4/P 17.25.50 p275
	20					3150 ⁽¹⁾	VD4/P 17.32.20 p275
	25					3150 ⁽¹⁾	VD4/P 17.32.25 p275
	31.5					3150 ⁽¹⁾	VD4/P 17.32.32 p275
	40					3150 ⁽¹⁾	VD4/P 17.32.40 p275
	50					3150 ⁽¹⁾	VD4/P 17.32.50 p275

W = Width of the circuit-breaker.

P = Pole horizontal centre distance.

u/l = Distance between bottom and top terminal.

ø = Diameter of the isolating contact.

(1) Up to 4000 A with forced ventilation.

2. Selection and ordering

Withdrawable circuit-breakers

VD4 (24 kV) withdrawable circuit-breaker for UniGear ZS1 switchboard

Ur	Isc	Rated uninterrupted current (40 °C) [A]				Circuit-breaker type
		W=800	W=1000	W=1000	W=1000	
kV	kA	P=210	P=275	P=275	P=275	
		u/l=310	u/l=310	u/l=310	u/l=310	
		ø=35	ø=35	ø=79	ø=109	
24	16	630				VD4/P 24.06.16 p210
	20	630				VD4/P 24.06.20 p210
	25	630				VD4/P 24.06.25 p210
	16	1250				VD4/P 24.12.16 p210
	20	1250				VD4/P 24.12.20 p210
	25	1250				VD4/P 24.12.25 p210
	31.5	1250				VD4/P 24.12.32 p210
	16		630			VD4/P 24.06.16 p275
	20		630			VD4/P 24.06.20 p275
	25		630			VD4/P 24.06.25 p275
	16		1250			VD4/P 24.12.16 p275
	20		1250			VD4/P 24.12.20 p275
	25		1250			VD4/P 24.12.25 p275
	16			1600		VD4/P 24.16.16 p275
	20			1600		VD4/P 24.16.20 p275
	25			1600		VD4/P 24.16.25 p275
	31.5			1600		VD4/P 24.16.32 p275
	16			2000		VD4/P 24.20.16 p275
	20			2000		VD4/P 24.20.20 p275
	25			2000		VD4/P 24.20.25 p275
	31.5			2000		VD4/P 24.20.32 p275
	16			2300 ⁽¹⁾		VD4/P 24.25.16 p275
	20			2300 ⁽¹⁾		VD4/P 24.25.20 p275
	25			2300 ⁽¹⁾		VD4/P 24.25.25 p275
	31.5			2300 ⁽¹⁾		VD4/P 24.25.32 p275
	31.5				2700 ⁽²⁾	VD4/P 24.32.32 p275

W = Width of the switchgear.

P = Pole horizontal centre distance.

u/l = Distance between bottom and top terminal.

ø = Diameter of the isolating contact.

(1) 2500 A rated current guaranteed with forced ventilation.

(2) 3150 A rated current guaranteed with forced ventilation.

VD4 (36 kV) withdrawable circuit-breaker

Ur	Isc	Rated uninterrupted current (40 °C) [A]	
kV	kA	H=951	Circuit-breaker type
		D=788	
		u/l=380	
		ø=399	
		P=275	
		W=778	
36	31.5	1250 A	VD4/W 36.12.32 p275
		1600 A	VD4/W 36.16.32 p275
		2000 A	VD4/W 36.20.32 p275
		2500 A (*)	VD4/W 36.25.32 p275

H = Height of the circuit-breaker.
D = Depth of the circuit-breaker.
u/l = Distance between bottom and top terminal.
ø = Diameter of the isolating contact.
P = Pole horizontal centre distance.
W = Width of the circuit-breaker.
(*) = Contact ABB.

Standard fittings of withdrawable circuit-breakers for UniGear ZS1, ZS2 switchgear and similar panels

The basic versions of the withdrawable circuit-breakers are three-pole and fitted with:

- EL type manual operating mechanism
- mechanical signalling device for closing springs charged/discharged
- mechanical signalling device for circuit-breaker open/closed
- closing pushbutton
- opening pushbutton
- operation counter
- set of ten circuit-breaker open/closed auxiliary contacts
Note: with the group of ten auxiliary contacts supplied as standard and the maximum number of electrical applications, three break contacts (signalling circuit-breaker open) and four make contacts (signalling circuit-breaker closed) are available.
- lever for manually charging the closing springs
- isolating contacts
- cord with connector (plug only) for auxiliary circuits, with striker pins which does not allow the plug to be inserted into the socket if the rated current of the circuit-breaker is lower than the rated current of the panel
- racking-out/in lever (the quantity must be defined according to the number of pieces of apparatus ordered)

- locking electromagnet in the truck (compulsory for ABB switchgear). This device prevents racking the circuit-breaker into the switchgear with the auxiliary circuits disconnected (plug not inserted in the socket)
- door interlock (compulsory for ABB switchgear); this device prevents racking the circuit-breaker into the switchgear when the switchgear door is open.



VD4 – up to 24 kV



VD4 - 36 kV

2. Selection and ordering

Withdrawable circuit-breakers

Withdrawable version circuit-breakers for PowerCube modules (12 kV)

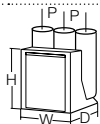

Circuit-breaker	PowerCube module	VD4/P 12 ⁽³⁾		VD4/W 12 ⁽³⁾		
		PB1		PB2		
Standards	IEC 62271-100 VDE 0671; CEI EN 62271-100- File 7642	•	•	•	•	
Rated voltage	Ur [kV]	12	12	12	12	
Rated insulation voltage	Us [kV]	12	12	12	12	
Withstand voltage at 50 Hz	Ud (1 min) [kV]	28	28	28	28	
Impulse withstand voltage	Up [kV]	75	75	75	75	
Rated frequency	fr [Hz]	50-60	50-60	50-60	50-60	
Rated normal current (40 °C) ⁽¹⁾	Ir [A]	630	1250	630	1250	
		16	16	16	16	
		20	20	20	20	
		25	25	25	25	
		31.5	31.5	31.5	31.5	
		—	—	—	—	
Rated breaking capacity (rated short-circuit breaking current symmetrical)	Isc [kA]	16	16	16	16	
		20	20	20	20	
		25	25	25	25	
		31.5	31.5	31.5	31.5	
		—	—	—	—	
		—	—	—	—	
Rated short-time withstand current (3s)	Ik [kA]	16	16	16	16	
		20	20	20	20	
		25	25	25	25	
		31.5	31.5	31.5	31.5	
		—	—	—	—	
		—	—	—	—	
Making capacity	Ip [kA]	40	40	40	40	
		50	50	50	50	
		63	63	63	63	
		80	80	80	80	
		—	—	—	—	
		—	—	—	—	
Operation sequence	[O - 0.3 s - CO - 15 s - CO]	•	•	•	•	
Opening time	[ms]	33 ... 60	33 ... 60	33 ... 60	33 ... 60	
Arcing time	[ms]	10 ... 15	10 ... 15	10 ... 15	10 ... 15	
Total breaking time	[ms]	43 ... 75	43 ... 75	43 ... 75	43 ... 75	
Closing time	[ms]	60 ... 80	60 ... 80	60 ... 80	60 ... 80	
Maximum overall dimensions		H [mm]	628	628	691	691
		W [mm]	503	503	653	853
		D [mm]	662	662	642	642
		Pole distance P [mm]	150	150	210	210
Weight	[kg]	116	116	135	135	
Standardised table of dimensions	TN	7412	7412	7420	7420	
	1VCD	—	—	—	—	
Operating temperature	[°C]	- 5 ... + 40	- 5 ... + 40	- 5 ... + 40	- 5 ... + 40	
Tropicalization	IEC: 60068-2-30, 60721-2-1	•	•	•	•	
Electromagnetic compatibility	IEC: 62271-1	•	•	•	•	

Provided by Northeast Power Systems, Inc.
www.nepsi.com

(1) Rated current guaranteed with circuit-breaker installed in PowerCube enclosure and with 40 °C ambient temperature
(2) Up to 4000 A with forced ventilation.
(3) Circuit-breakers up to 1250 A and 31.5 kA have polyamide poles.

VD4/P 12 PB2									VD4/W 12 PB3	
•									•	•
•									•	•
12									12	12
12									12	12
28									28	28
75									75	75
50-60									50-60	50-60
1250	1250	1600	1600	1600	2000	2000	2500	2500	3150 ⁽²⁾	3150 ⁽²⁾
—	—	—	—	—	—	—	—	—	—	—
—	—	20	—	—	20	—	20	—	20	—
—	—	25	—	—	25	—	25	—	25	—
—	—	31.5	—	—	31.5	—	31.5	—	31.5	—
40	—	—	40	—	40	—	40	—	40	—
—	50	—	—	50	—	50	—	50	—	50
—	—	—	—	—	—	—	—	—	—	—
—	—	20	—	—	20	—	20	—	20	—
—	—	25	—	—	25	—	25	—	25	—
—	—	31.5	—	—	31.5	—	31.5	—	31.5	—
40	—	—	40	—	40	—	40	—	40	—
—	50	—	—	50	—	50	—	50	—	50
—	—	—	—	—	—	—	—	—	—	—
—	—	50	—	—	50	—	50	—	50	—
—	—	63	—	—	63	—	63	—	63	—
—	—	80	—	—	80	—	80	—	80	—
100	—	—	100	—	100	—	100	—	100	—
—	125	—	—	125	—	125	—	125	—	125
•									•	•
33 ... 60									33 ... 60	33 ... 60
10 ... 15									10 ... 15	10 ... 15
43 ... 75									43 ... 75	43 ... 75
60 ... 80									60 ... 80	60 ... 80
691	691	691	691	691	690	691	691	691	730	691
653	681	653	653	681	653	681	853	853	853	853
641	643	642	641	643	642	643	640	643	640	643
210	210	210	210	210	210	210	275	275	275	275
174	180	160	174	180	160	190	186	225	221	240
—	—	7415	—	—	7415	—	7417	—	—	—
003284	003444	—	003284	003444	—	003444	—	003445	000152	003596
- 5 ... + 40									- 5 ... + 40	- 5 ... + 40
•									•	•
•									•	•

2. Selection and ordering

Withdrawable circuit-breakers

Withdrawable version circuit-breakers for PowerCube modules (17.5 kV)

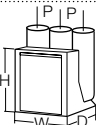

Circuit-breaker	VD4/P 17 ⁽³⁾		VD4/W 17 ⁽³⁾		
	PowerCube module	PB1	PB2		
Standards	IEC 62271-100	•	•		
	VDE 0671; CEI EN 62271-100- File 7642	•	•		
Rated voltage	Ur [kV]	17.5	17.5		
Rated insulation voltage	Us [kV]	17.5	17.5		
Withstand voltage at 50 Hz	Ud (1 min) [kV]	38	38		
Impulse withstand voltage	Up [kV]	95	95		
Rated frequency	fr [Hz]	50-60	50-60		
Rated normal current (40 °C) ⁽¹⁾	Ir [A]	630	1250	630	
		16	16	16	
Rated breaking capacity (rated short-circuit breaking current symmetrical)	Isc [kA]	20	20	20	
		25	25	25	
		31.5	31.5	31.5	
		—	—	—	
		—	—	—	
Rated short-time withstand current (3s)	Ik [kA]	16	16	16	
		20	20	20	
		25	25	25	
		31.5	31.5	31.5	
		—	—	—	
Making capacity	Ip [kA]	40	40	40	
		50	50	50	
		63	63	63	
		80	80	80	
		—	—	—	
Operation sequence	[O - 0.3 s - CO - 15 s - CO]	•	•		
Opening time	[ms]	33 ... 60	33 ... 60		
Arcing time	[ms]	10 ... 15	10 ... 15		
Total breaking time	[ms]	43 ... 75	43 ... 75		
Closing time	[ms]	60 ... 80	60 ... 80		
Maximum overall dimensions		H [mm]	628	628	691
		W [mm]	503	503	653
		D [mm]	662	662	642
		Pole distance P [mm]	150	150	210
Weight	[kg]	116	116	135	
Standardised table of dimensions	TN	7412	7412	7420	
	1VCD	—	—	—	
Operating temperature	[°C]	- 5 ... + 40	- 5 ... + 40		
Tropicalization	IEC: 60068-2-30, 60721-2-1	•	•		
Electromagnetic compatibility	IEC: 62271-1	•	•		

(1) Rated current guaranteed with circuit-breaker installed in PowerCube enclosure and with 40 °C ambient temperature.

(2) Up to 4000 A with forced ventilation.

(3) Circuit-breakers up to 1250 A and 31.5 kA have polyamide poles.

VD4/P 17								VD4/W 17			
PB2								PB3		PB3	
•								•		•	
•								•		•	
17,5								17,5		17,5	
17,5								17,5		17,5	
38								38		38	
95								95		95	
50-60								50-60		50-60	
1250	1250	1600	1600	1600	2000	2000	2500	2500	3150 ⁽²⁾	3150 ⁽²⁾	
—	—	—	—	—	—	—	—	—	—	—	—
—	—	20	—	—	20	—	20	—	—	20	—
—	—	25	—	—	25	—	25	—	—	25	—
—	—	31.5	—	—	31.5	—	31.5	—	—	31.5	—
40	—	—	40	—	40	—	40	—	—	40	—
—	50	—	—	50	—	50	—	50	50	—	—
—	—	—	—	—	—	—	—	—	—	—	—
—	—	20	—	—	20	—	20	—	—	20	—
—	—	25	—	—	25	—	25	—	—	25	—
—	—	31.5	—	—	31.5	—	31.5	—	—	31.5	—
40	—	—	40	—	40	—	40	—	—	40	—
—	50	—	—	50	—	50	—	50	50	—	—
—	—	—	—	—	—	—	—	—	—	—	—
—	—	50	—	—	50	—	50	—	—	50	—
—	—	63	—	—	63	—	63	—	—	63	—
—	—	80	—	—	80	—	80	—	—	80	—
100	—	—	100	—	100	—	100	—	—	100	—
—	125	—	—	125	—	125	—	125	125	—	—
•								•		•	
33 ... 60								33 ... 60		33 ... 60	
10 ... 15								10 ... 15		10 ... 15	
43 ... 75								43 ... 75		43 ... 75	
60 ... 80								60 ... 80		60 ... 80	
691	691	691	691	691	690	691	691	691	691	691	730
653	681	653	653	681	653	681	853	853	853	853	853
641	643	642	641	643	642	643	640	643	643	643	640
210	210	210	210	210	210	210	275	275	275	275	275
174	180	160	174	180	160	190	186	225	240	240	221
—	—	7415	—	—	7415	—	7417	—	—	—	—
003284	003444	—	003284	003444	—	003444	—	003445	003596	000152	
- 5 ... + 40								- 5 ... + 40		- 5 ... + 40	
•								•		•	
•								•		•	

2. Selection and ordering

Withdrawable circuit-breakers

Withdrawable version circuit-breakers for PowerCube modules (24 kV)

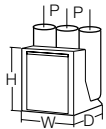

Circuit-breaker	VD4/P 24						
	PowerCube module	PB4		PB5			
Standards	IEC 62271-100	•		•			
	VDE 0671; CEI EN 62271-100- File 7642	•		•			
Rated voltage	Ur [kV]	24		24			
Rated insulation voltage	Us [kV]	24		24			
Withstand voltage at 50 Hz	Ud (1 min) [kV]	50		50			
Impulse withstand voltage	Up [kV]	125		125			
Rated frequency	fr [Hz]	50-60		50-60			
Rated normal current (40 °C) ⁽¹⁾	Ir [A]	630	1250	1600	2000	2500 ⁽²⁾	
		16	16	16	16	16	
Rated breaking capacity (rated short-circuit breaking current symmetrical)	Isc [kA]	20	20	20	20	20	
		25	25	25	25	25	
		–	31.5	31.5	31.5	31.5	
		16	16	16	16	16	
Rated short-time withstand current (3s)	Ik [kA]	20	20	20	20	20	
		25	25	25	25	25	
		–	31.5	31.5	31.5	31.5	
		40	40	40	40	40	
Making capacity	Ip [kA]	50	50	50	50	50	
		63	63	63	63	63	
		–	80	80	80	80	
Operation sequence	[O - 0.3 s - CO - 15 s - CO]	•	•	•	•	•	
Opening time	[ms]	33 ... 60		33 ... 60			
Arcing time	[ms]	10 ... 15		10 ... 15			
Total breaking time	[ms]	43 ... 75		43 ... 75			
Closing time	[ms]	60 ... 80		60 ... 80			
Maximum overall dimensions		H [mm]	794	794	838	838	838
		W [mm]	653	653	853	853	853
		D [mm]	802	802	790	790	790
		Pole distance P [mm]	210	210	275	275	275
Weight	[kg]	140	140/146 ⁽³⁾	228	228	228	
Standardised table of dimensions	TN	7413	7413	7418	7418	7418	
	1VCD	–	000173 ⁽³⁾	–	–	–	
Operating temperature	[°C]	- 5 ... + 40					
Tropicalization	IEC: 60068-2-30, 60721-2-1	•					
Electromagnetic compatibility	IEC: 62271-1	•					

(1) Rated current guaranteed with circuit-breaker installed in PowerCube enclosure and with 40 °C ambient temperature.

(2) 2300 A rated uninterrupted current guaranteed with natural ventilation; 2500 A rated current guaranteed with forced ventilation.

(3) 31.5 kA version.

Types of withdrawable version circuit-breakers available for PowerCube modules

Complete the circuit-breaker selected with the optional accessories indicated on the following pages.

VD4 withdrawable circuit-breaker (12 kV)

Ur	Isc	Rated uninterrupted current (40 °C) [A]					Circuit-breaker type
		W=650 P=150 u/l=205 ø=35	W=800 P=210 u/l=310 ø=79	W=1000 P=275 u/l=310 ø=79	W=1000 P=275 u/l=310 ø=109	W=1000 P=275 u/l=310 ø=109	
12	16	630					VD4/P 12.06.16 p150
	20	630					VD4/P 12.06.20 p150
	25	630					VD4/P 12.06.25 p150
	31.5	630					VD4/P 12.06.32 p150
	16	1250					VD4/P 12.12.16 p150
	20	1250					VD4/P 12.12.20 p150
	25	1250					VD4/P 12.12.25 p150
	31.5	1250					VD4/P 12.12.32 p150
	16		630				VD4/W 12.06.16 p210
	20		630				VD4/W 12.06.20 p210
	25		630				VD4/W 12.06.25 p210
	31.5		630				VD4/W 12.06.32 p210
	16		1250				VD4/W 12.12.16 p210
	20		1250				VD4/W 12.12.20 p210
	25		1250				VD4/W 12.12.25 p210
	31.5		1250				VD4/W 12.12.32 p210
	40		1250				VD4/P 12.12.40 p210
	50		1250				VD4/P 12.12.50 p210
	20			1600			VD4/P 12.16.20 p210
	25			1600			VD4/P 12.16.25 p210
31.5			1600			VD4/P 12.16.32 p210	
40			1600			VD4/P 12.16.40 p210	
50			1600			VD4/P 12.16.50 p210	
20			2000			VD4/P 12.20.20 p210	
25			2000			VD4/P 12.20.25 p210	
31.5			2000			VD4/P 12.20.32 p210	
40			2000			VD4/P 12.20.40 p210	
50			2000			VD4/P 12.20.50 p210	
20				2500		VD4/P 12.25.20 p275	
25				2500		VD4/P 12.25.25 p275	
31.5				2500		VD4/P 12.25.32 p275	
40				2500		VD4/P 12.25.40 p275	
50				2500		VD4/P 12.25.50 p275	
20					3150 ⁽¹⁾	VD4/W 12.32.20 p275	
25					3150 ⁽¹⁾	VD4/W 12.32.25 p275	
31.5					3150 ⁽¹⁾	VD4/W 12.32.32 p275	
40					3150 ⁽¹⁾	VD4/W 12.32.40 p275	
50					3150 ⁽¹⁾	VD4/W 12.32.50 p275	

W = Width of the switchgear.
P = Pole horizontal centre distance.
u/l = Distance between bottom and top terminal.
ø = Diameter of the isolating contact.
(1) Up to 4000 A with forced ventilation.

2. Selection and ordering Withdrawable circuit-breakers

VD4 withdrawable circuit-breaker (17.5 kV)

Ur	Isc	Rated uninterrupted current (40 °C) [A]					Circuit-breaker type
		W=650 P=150 u/l=205 ø=35	W=800 P=210 u/l=310 ø=79	W=1000 P=275 u/l=310 ø=79	W=1000 P=275 u/l=310 ø=109	W=1000 P=275 u/l=310 ø=109	
17,5	16	630					VD4/P 17.06.16 p150
	20	630					VD4/P 17.06.20 p150
	25	630					VD4/P 17.06.25 p150
	31.5	630					VD4/P 17.06.32 p150
	16	1250					VD4/P 17.12.16 p150
	20	1250					VD4/P 17.12.20 p150
	25	1250					VD4/P 17.12.25 p150
	31.5	1250					VD4/P 17.12.32 p150
	16		630				VD4/W 17.06.16 p210
	20		630				VD4/W 17.06.20 p210
	25		630				VD4/W 17.06.25 p210
	31.5		630				VD4/W 17.06.32 p210
	16		1250				VD4/W 17.12.16 p210
	20		1250				VD4/W 17.12.20 p210
	25		1250				VD4/W 17.12.25 p210
	31.5		1250				VD4/W 17.12.32 p210
	40		1250				VD4/P 17.12.40 p210
	50		1250				VD4/P 17.12.50 p210
	20			1600			VD4/P 17.16.20 p210
	25			1600			VD4/P 17.16.25 p210
31.5			1600			VD4/P 17.16.32 p210	
40			1600			VD4/P 17.16.40 p210	
50			1600			VD4/P 17.16.50 p210	
20			2000			VD4/P 17.20.20 p210	
25			2000			VD4/P 17.20.25 p210	
31.5			2000			VD4/P 17.20.32 p210	
40			2000			VD4/P 17.20.40 p210	
50			2000			VD4/P 17.20.50 p210	
20				2500		VD4/P 17.25.20 p275	
25				2500		VD4/P 17.25.25 p275	
31.5				2500		VD4/P 17.25.32 p275	
40				2500		VD4/P 17.25.40 p275	
50				2500		VD4/P 17.25.50 p275	
20					3150 ⁽¹⁾	VD4/W 17.32.20 p275	
25					3150 ⁽¹⁾	VD4/W 17.32.25 p275	
31.5					3150 ⁽¹⁾	VD4/W 17.32.32 p275	
40					3150 ⁽¹⁾	VD4/W 17.32.40 p275	
50					3150 ⁽¹⁾	VD4/W 17.32.50 p275	

W = Width of the switchgear.
P = Pole horizontal centre distance.
u/l = Distance between bottom and top terminal.
ø = Diameter of the isolating contact.
(1) Up to 4000 A with forced ventilation.

VD4 withdrawable circuit-breaker (24 kV)

Ur	Isc	Rated uninterrupted current (40 °C) [A]		Circuit-breaker type	
		W=800	W=1000		
kV	kA	P=210	P=275		
		u/l=310	u/l=310		
		ø=35	ø=79		
24	16	630		VD4/P 24.06.16 p210	
	20	630		VD4/P 24.06.20 p210	
	25	630		VD4/P 24.06.25 p210	
	16	1250		VD4/P 24.12.16 p210	
	20	1250		VD4/P 24.12.20 p210	
	25	1250		VD4/P 24.12.25 p210	
	31.5	1250		VD4/P 24.12.32 p210	
	16		1600	VD4/P 24.16.16 p275	
	20		1600	VD4/P 24.16.20 p275	
	25		1600	VD4/P 24.16.25 p275	
	31.5		1600	VD4/P 24.16.32 p275	
	16		2000	VD4/P 24.20.16 p275	
	20		2000	VD4/P 24.20.20 p275	
	25		2000	VD4/P 24.20.25 p275	
	31.5		2000	VD4/P 24.20.32 p275	
	16		2300 ⁽¹⁾	VD4/P 24.25.16 p275	
	20		2300 ⁽¹⁾	VD4/P 24.25.20 p275	
	25		2300 ⁽¹⁾	VD4/P 24.25.25 p275	
	31.5		2300 ⁽¹⁾	VD4/P 24.25.32 p275	

W = Width of the switchgear.

P = Pole horizontal centre distance.

u/l = Distance between bottom and top terminal.

Ø = Diameter of the isolating contact.

(1) Up to 2500 A rated current guaranteed with forced ventilation.

Standard fittings of withdrawable circuit-breakers for PowerCube modules

The basic versions of the withdrawable circuit-breakers are always three-pole and fitted with:

- EL type manual operating mechanism
- mechanical signalling device for closing springs charged/discharged
- mechanical signalling device for circuit-breaker open/closed
- closing pushbutton
- opening pushbutton
- operation counter
- set of ten circuit-breaker open/closed auxiliary contacts
Note: with the group of ten auxiliary contacts supplied as standard and the maximum number of electrical applications, three break contacts (signalling circuit-breaker open) and four make contacts (signalling circuit-breaker closed) are available.
- lever for manually charging the closing springs
- isolating contacts
- cord with connector (plug only) for auxiliary circuits, with striker pin which does not allow the plug to be inserted into the socket if the rated current of the circuit-breaker is different from the rated current of the panel

- racking-in/out lever (the quantity must be defined according to the number of pieces of apparatus ordered)
- locking electromagnet in the truck. This prevents the circuit-breaker being racked into the panel with the auxiliary circuits disconnected (plug not inserted in the socket).
- door interlock (compulsory for ABB switchgear); this device prevents racking the circuit-breaker into the switchgear when the switchgear door is open.



2. Selection and ordering

Withdrawable circuit-breakers

Withdrawable circuit-breakers for ZS8.4 type switchgear (12 - 17.5 - 24 kV)



Circuit-breaker		VD4/Z8					
	Panel without partitions	•					
	Panel with partitions	—					
	Preussen Elektra - EON ⁽²⁾	—					
	Width [mm]	650	650	650	650	800	800
	Depth [mm]	1000	1000	1000	1000	1200	1200
Standards	IEC 62271-100	•					
	VDE 0671	•					
Rated voltage	Ur [kV]	12	12	17.5	17.5	24	24
Rated insulation voltage	Us [kV]	12	12	17.5	17.5	24	24
Withstand voltage at 50 Hz	Ud (1 min) [kV]	28	28	38	38	50	50
Impulse withstand voltage	Up [kV]	75	75	95	95	125	125
Rated frequency	fr [Hz]	50-60					
Rated normal current (40 °C) ⁽¹⁾	Ir [A]	630	1250	630	1250	630	1250
Rated breaking capacity (rated symmetrical short-circuit current)	Isc [kA]	—	—	—	—	16	16
		20	20	20	20	20	20
Rated short-time withstand current(3 s)	Ik [kA]	25	25	25	25	25	25
		—	—	—	—	16	16
		20	20	20	20	20	20
Making capacity	Ip [kA]	25	25	25	25	25	25
		—	—	—	—	40	40
Operation sequence	[O-0.3s-CO-15s-CO]	•					
		•					
Opening time	[ms]	33...60					
Arcing time	[ms]	10...15					
Total breaking time	[ms]	43...75					
Closing time	[ms]	60...80					
Maximum overall dimensions	H [mm]	579	579	579	579	680	680
	W [mm]	503	503	503	503	653	653
	D [mm]	548	548	548	548	646	646
	Pole distance P [mm]	150	150	150	150	210	210
Weight	[kg]	116	116	116	116	140	140
Standardised table of dimensions	1VCD	000092	000137	000137	000137	000089	000138
Operating temperature	[°C]	- 5 ... + 40					
Tropicalisation	IEC 60068-2-30	•					
	IEC 60721-2-1	•					
Electromagnetic compatibility	IEC 62271-1	•					

Provided by Northeast Power Systems, Inc.
www.nepsi.com

(1) Rated current guaranteed with circuit-breaker installed in switchgear with 40 °C ambient temperature.

(2) Special type with device for charging the closing spring by means of a rotary handle outside the operating mechanism.

VD4/ZT8						VD4/ZS8				
—						—				
•						—				
—						•				
650	650	650	650	800	800	650	650	800	800	
1200	1200	1200	1200	1200	1200	1200	1200	1200	1200	
•						•				
•						•				
12	12	17.5	17.5	24	24	12	12	24	24	
12	12	17.5	17.5	24	24	12	12	24	24	
28	28	38	38	50	50	28	28	50	50	
75	75	95	95	125	125	75	75	125	125	
50-60						50-60				
630	1250	630	1250	630	1250	630	1250	630	1250	
—	—	—	—	16	16	—	—	16	16	
20	20	20	20	20	20	20	20	20	20	
25	25	25	25	25	25	25	25	25	25	
—	—	—	—	16	16	—	—	16	16	
20	20	20	20	20	20	20	20	20	20	
25	25	25	25	25	25	25	25	25	25	
—	—	—	—	40	40	—	—	40	40	
50	50	50	50	50	50	50	50	50	50	
63	63	63	63	63	63	63	63	63	63	
•						•				
33...60						40...60				
10...15						10...15				
43...75						50...75				
60...80						60...80				
579	579	579	579	680	680	579	579	680	680	
503	503	503	503	653	653	503	503	653	653	
638	638	638	638	646	646	638	638	646	646	
150	150	150	150	210	210	150	150	210	210	
116	116	116	116	140	140	116	116	140	140	
000093	000134	000134	000134	000090	000136	000091	000133	000088	000135	
- 5 ... + 40						- 5 ... + 40				
•						•				
•						•				
•						•				

2. Selection and ordering Withdrawable circuit-breakers

VD4/ZS8 - VD4/ZT8 - VD4/Z8 withdrawable circuit-breaker for ZS8.4 switchgear

Ur	Isc	Rated uninterrupted current (40°C) [A]						Circuit-breaker type							
		Panel without partition		Panel with partition		Special panel EON									
		W = 650 P = 150 u/l = 205 ø = 35	W = 800 P = 210 u/l = 310 ø = 35	W = 650 P = 150 u/l = 205 ø = 35	W = 800 P = 210 u/l = 310 ø = 35	W = 650 P = 150 u/l = 205 ø = 35	W = 800 P = 210 u/l = 310 ø = 35								
12	20	630						VD4/Z8 12.06.20 p150							
								25	630					VD4/Z8 12.06.25 p150	
								20	1250					VD4/Z8 12.12.20 p150	
								25	1250					VD4/Z8 12.12.25 p150	
	25				630				VD4/ZT8 12.06.20 p150						
									25	630					VD4/ZT8 12.06.25 p150
									20	1250					VD4/ZT8 12.12.20 p150
									25	1250					VD4/ZT8 12.12.25 p150
	20						630		VD4/ZS8 12.06.20 p150						
									25	630					VD4/ZS8 12.06.25 p150
									20	1250					VD4/ZS8 12.12.20 p150
									25	1250					VD4/ZS8 12.12.25 p150
17.5	20	630						VD4/Z8 17.06.20 p150							
								25	630					VD4/Z8 17.06.25 p150	
								20	1250					VD4/Z8 17.12.20 p150	
								25	1250					VD4/Z8 17.12.25 p150	
	25				630				VD4/ZT8 17.06.20 p150						
									25	630					VD4/ZT8 17.06.25 p150
									20	1250					VD4/ZT8 17.12.20 p150
									25	1250					VD4/ZT8 17.12.25 p150
24	16	630						VD4/Z8 24.06.16 p210							
								20	630					VD4/Z8 24.06.20 p210	
								25	630					VD4/Z8 24.06.25 p210	
								16	1250					VD4/Z8 24.12.16 p210	
								20	1250					VD4/Z8 24.12.20 p210	
								25	1250					VD4/Z8 24.12.25 p210	
	20						630		VD4/ZT8 24.06.16 p210						
									20	630					VD4/ZT8 24.06.20 p210
									25	630					VD4/ZT8 24.06.25 p210
									16	1250					VD4/ZT8 24.12.16 p210
									20	1250					VD4/ZT8 24.12.20 p210
									25	1250					VD4/ZT8 24.12.25 p210
	16							630	VD4/ZS8 24.06.16 p210						
									20	630					VD4/ZS8 24.06.20 p210
									25	630					VD4/ZS8 24.06.25 p210
									16	1250					VD4/ZS8 24.12.16 p210
20							1250	VD4/ZS8 24.12.20 p210							
								20	1250					VD4/ZS8 24.12.20 p210	
								25	1250					VD4/ZS8 24.12.25 p210	
								16	1250					VD4/ZS8 24.12.16 p210	

W = Width of the switchgear.
P = Pole horizontal centre distance.
u/l = Distance between bottom and top terminal.
Ø = Diameter of the isolating contact.

Standard fittings of withdrawable circuit-breakers for ZS8.4 switchgear

The basic versions of the withdrawable circuit-breakers are three-pole and fitted with:

- EL type manual operating mechanism
- mechanical signalling device for closing springs charged/ discharged
- mechanical signalling device for circuit-breaker open/closed
- closing pushbutton
- opening pushbutton
- operation counter
- set of ten circuit-breaker open/closed auxiliary contacts

Note: with the group of ten auxiliary contacts supplied as standard and the maximum number of electrical applications, three break contacts (signalling circuit-breaker open) and four make contacts (signalling circuit-breaker closed) are available.

- lever for manually charging the closing springs incorporated in the operating mechanism for VD4/Z8 and VD4/ZT8, external with rotary movement for VD4/ZS8
- isolating contacts
- racking in/out lever (the quantity must be defined according to the number of pieces of apparatus ordered)

VD4/ZS8 (Preussen Elektra-EON version)

- device for closing spring charging, with the door closed, by means of a removable rotary crank handle outside the operating mechanism and the switchgear
- Harting 64-pin socket with mechanical interlock which prevents traverse of the circuit-breaker when the plug is not inserted in the socket
- interlock with the door which prevents the spring charging lever when the circuit-breaker is closed
- interlock with the door and Harting 64 pin socket which prevents door closing when the plug is not inserted in the socket.

VD4/Z8 - VD4/ZT8

- Harting 64-pin socket with mechanical interlock which prevents traverse of the circuit-breaker when the plug is not inserted in the socket.



Caption
1) Spring charging device with rotary crank handle
2) Harting 64 plus socket with mechanical interlock which prevents traverse when the socket is not inserted
3) Door - socket - spring charging device interlock (only VD4/ZS8 version)

2. Selection and ordering

Withdrawable circuit-breakers

Withdrawable circuit-breakers for UniSwitch switchgear (CBW type unit) and UniMix switchgear (P1/E type unit) (24 kV)



Circuit-breaker		VD4/US 24 ⁽³⁾	VD4/US 24 ⁽⁴⁾
	UniSwitch (unit CBW type)	•	–
	UniMix (unit P1/E type)	–	•
Standards	IEC 62271-100	•	•
	VDE 0671; CEI EN 62271-100- File 7642	•	•
Rated voltage	Ur [kV]	24	24
Rated insulation voltage	Us [kV]	24	24
Withstand voltage at 50 Hz	Ud (1 min) [kV]	50	50
Impulse withstand voltage	Up [kV]	125	125
Rated frequency	fr [Hz]	50-60	50-60
	Rated normal current (40 °C) ⁽¹⁾	Ir [A]	630
Rated breaking capacity (rated symmetrical short-circuit current)		16 (20) ⁽⁵⁾	16
	Isc [kA]	20 (25) ⁽⁵⁾	20
		–	25
Rated short-time withstand current (3 s) ⁽²⁾		16 (20) ⁽⁵⁾	16
	Ik [kA]	20 (25) ⁽⁵⁾	20
		–	25
Making capacity		40 (50) ⁽⁵⁾	40
	Ip [kA]	50 (63) ⁽⁵⁾	50
Operation sequence	[O - 0.3 s - CO - 15 s - CO]	•	•
Opening time	[ms]	33 ... 60	33 ... 60
Arcing time	[ms]	10 ... 15	10 ... 15
Total breaking time	[ms]	43 ... 75	43 ... 75
Closing time	[ms]	60 ... 80	60 ... 80
Maximum overall dimensions	H [mm]	680	680
	W [mm]	653	653
	D [mm]	742	742
	Pole distance P [mm]	210	210
Weight	[kg]	125	125
Standardised table of dimensions	1VCD	000047	000047
Operating temperature	[°C]	- 5 ... + 40	- 5 ... + 40
Tropicalization	IEC: 60068-2-30, 60721-2-1	•	•
Electromagnetic compatibility	IEC 62271	•	•

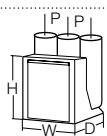

- (1) Rated current guaranteed with withdrawable circuit-breaker installed in switchgear with 40 °C ambient temperature
(2) The value and duration of the rated short-time withstand current depends on the switchgear. See the specific catalogues of the UniSwitch and UniMix switchgear
(3) The top shutter activation wheels of the UniSwitch switchgear (CBW unit) are mounted and adjusted by the manufacturer of the UniSwitch switchgear
(4) The top shutter activation wheels of the UniMix switchgear (P1/E unit) are available on request
(5) The values in brackets refer to the 12 kV rated voltage.

Withdrawable c.-breaker for UniSwitch switchgear (CBW type unit) and UniMix switchgear (P1/E type unit)

Ur	Isc	Rated uninterrupted current (40 °C) [A]		Circuit-breaker type
		UniSwitch CBW	UniMix P1/E	
kV	kA	P=210	P=210	
		u/l=310	u/l=310	
		ø=35	ø=79	
24	16	630 ⁽¹⁾	630	VD4/US 24.06.16 p210
	20	630 ⁽¹⁾	630	VD4/US 24.06.20 p210
	25	—	630	VD4/US 24.06.25 p210
	16	1250 ⁽¹⁾	1250	VD4/US 24.12.16 p210
	20	1250 ⁽¹⁾	1250	VD4/US 24.12.20 p210
	25	—	1250	VD4/US 24.12.25 p210

(1) Isc 25 kA at 12 kV.

P = Horizontal centre distance between poles.

u/l = Distance between top and bottom terminal.

Ø = Diameter of the isolating contacts.

Standard fittings of withdrawable circuit-breakers for UniSwitch and UniMix switchgear

The basic versions of the withdrawable circuit-breakers are three-pole and fitted with:

- EL type manual operating mechanism
- mechanical signalling device for closing springs charged/ discharged
- mechanical signalling device for circuit-breaker open/closed
- closing pushbutton
- opening pushbutton
- operation counter
- set of ten circuit-breaker open/closed auxiliary contacts
 Note: with the group of ten auxiliary contacts supplied as standard and the maximum number of electrical applications, three break contacts (signalling circuit-breaker open) and four make contacts (signalling circuit-breaker closed) are available.
- lever for manually charging the closing springs
- isolating contacts
- cord with connector (plug only) for auxiliary circuits, with striker pin which does not allow the plug to be inserted into the socket if the rated current of the circuit-breaker is different from the rated current of the panel
- racking-in/out lever (the quantity must be defined according to the number of pieces of apparatus ordered)
- locking electromagnet in the truck. This prevents the circuit-breaker being racked into the panel with the auxiliary circuits disconnected (plug not inserted in the socket).

2. Selection and ordering

Withdrawable circuit-breakers

General characteristics of withdrawable circuit-breakers for UniSec switchgear



Circuit-breaker	VD4/SEC
Standards	IEC 62271-100 • VDE 0671; CEI EN 62271-100- File 7642 •
Rated voltage	Ur [kV] 24
Rated insulation voltage	Us [kV] 24
Withstand voltage at 50 Hz	Ud (1 min) [kV] 50
Impulse withstand voltage	Up [kV] 125
Rated frequency	fr [Hz] 50-60
Rated normal current (40 °C) ⁽¹⁾	Ir [A] 630 - 1250
Rated breaking capacity (rated symmetrical short-circuit current)	16
	Isc [kA] 20
Rated short-time withstand current (3 s)	25
	16
Making capacity	Ik [kA] 20
	25
Opening time	40
	Ip [kA] 50
Opening time	63
	[O - 0.3 s - CO - 15 s - CO] •
Opening time	[ms] 33 ... 60
Arcing time	[ms] 10 ... 15
Total breaking time	[ms] 43 ... 75
Closing time	[ms] 60 ... 80
Maximum overall dimensions	H [mm] 743
	W [mm] 653
	D [mm] 742
	Pole distance P [mm] 210
Weight	[kg] 133
Standardised table of dimensions	1VCD 000190
Operating temperature	[°C] - 5 ... + 40
Tropicalization	IEC: 60068-2-30, 60721-2-1 •
Electromagnetic compatibility	IEC 62271 •

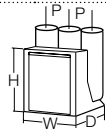

(1) Rated current guaranteed with withdrawable circuit-breaker installed in switchgear with 40 °C ambient temperature.

Withdrawable circuit-breaker for UniSec switchgear			Circuit-breaker type
Ur	Isc	Rated uninterrupted current (40 °C) [A]	
kV	kA	P=210	VD4/SEC 24.06.16 p210 VD4/SEC 24.06.20 p210 VD4/SEC 24.06.25 p210 VD4/SEC 24.12.16 p210 VD4/SEC 24.12.20 p210 VD4/SEC 24.12.25 p210
		u/l=310	
Ø=79			
24	16	630	
	20	630	
	25	630	
	16	1250	
	20	1250	
	25	1250	

P = Horizontal centre distance between poles.
 u/l = Distance between top and bottom terminal.
 Ø = Diameter of the isolating contacts.

Standard fittings of withdrawable circuit-breakers for UniSec

The basic versions of the withdrawable circuit-breakers are three-pole and fitted with:

- EL type manual operating mechanism
- mechanical signalling device for closing springs charged/ discharged
- mechanical signalling device for circuit-breaker open/closed
- closing pushbutton
- opening pushbutton
- operation counter
- set of ten circuit-breaker open/closed auxiliary contacts
 Note: with the group of ten auxiliary contacts supplied as standard and the maximum number of electrical applications, three break contacts (signalling circuit-breaker open) and four make contacts (signalling circuit-breaker closed) are available.
- lever for manual loading of the closing spring built into the operating mechanism
- isolating contacts
- cord with connector (plug only) for auxiliary circuits, with striker pin which does not allow the plug to be inserted into the socket if the rated current of the circuit-breaker is different from the rated current of the panel
- racking-in/out lever (the quantity must be defined according to the number of pieces of apparatus ordered)

2. Selection and ordering

Optional accessories

The accessories identified with the same number are alternative to each other.

1 Shunt opening release (-MO1)



This allows remote opening control of the apparatus. The release can operate both in direct and alternating current. This release is suitable for both instantaneous and permanent service. In the case of instantaneous service, the minimum current impulse time must be 100 ms.

Checking functionality and continuity is only possible using the STU device (accessory 21).

Characteristics

Un	24 - 30 - 48 - 60 - 110 - 125 - 220 - 250 V-
Un	48 - 60 - 110 - 120...127 - 220...240 - V- 50 Hz
Un	110 - 120 - 127 - 220 - 240 - V- 60 Hz
Operating limits	70 ... 110 % Un
Power on inrush (Ps)	DC 200 W; AC = 200 VA
Inrush duration	approx. 100 ms
Continuous power (Pc)	DC = 5 W; AC = 5 VA
Opening time ⁽¹⁾	40...60 ms
Closing time ⁽²⁾	40...80 ms
Insulation voltage	2000 V 50 Hz (for 1 min)

⁽¹⁾ Valid for -MO1 e -MO2.

⁽²⁾ Valid for -MC.

2 Additional shunt opening release (-MO2)



Like the shunt opening release described above, this allows remote opening control of the apparatus and can be supplied by a circuit completely separate from the release (-MO1). It keeps all the electrical and operating characteristics of the shunt opening release.

Checking functionality and continuity is only possible using the STU device (accessory 21).

3 Opening solenoid (-MO3)



The opening solenoid (-MO3) is a special release with demagnetisation to be combined with an overcurrent protection relay of the self-supplied type.

It is located in the operating mechanism (in the left side piece) and is not alternative to the additional shunt opening release (-MO2).

It is not available for 40 and 50 kA circuit-breakers.

Should the application of this accessory be required, specify the request at the time of order since subsequent application by the customer is not possible.

Note: for combination with the protection relays, please ask for the document: Data sheet 1VCD600854.

4 Shunt closing release (-MC)



This allows remote closing control of the apparatus. The release can operate both in direct and alternating current. This release is suitable both for instantaneous and permanent service.

In the case of instantaneous service, the minimum current impulse time must be 100 ms.

Use of the permanently supplied release is recommended to carry out the electrical anti-pumping function.

It keeps all the electrical and operating characteristics of the shunt opening release.

Checking functionality and continuity is only possible using the STU device (accessory 21).

2. Selection and ordering

Optional accessories

5 Undervoltage release (-MU)



The undervoltage release opens the circuit-breaker when there is notable lowering or lack of its power supply. It can be used for remote trip (by means of normally closed type pushbuttons), lock on closing or to control the voltage in the auxiliary circuits.

The circuit-breaker can only close with the release supplied (the closing lock is made mechanically).

The release can operate both in direct and alternating current.

Note

As an alternative to the undervoltage release, an additional shunt opening release (-MO4) with the same electrical and operating specifications as shunt opening release (-MO1) can be installed on request.

Warning! Installation of the additional shunt opening release (-MO4) requires a special mounting plate for releases.

Moreover, application (-MO4) must be requested at the time of order and not afterwards.

The undervoltage release is available in the following versions:

5A Undervoltage release with power supply branched on the supply side.

5B Undervoltage release with electronic time delay - KT (0.5 - 1 - 1.5 - 2 - 3s) (power supply branched on the supply side). This device is set at 0.5s (for adjustment, please see the Electric Circuit Diagram chapter).

Characteristics

Un	24 - 30 - 48 - 60 - 110 - 125 - 220 - 250 V~
Un	48 - 60 - 110 - 120 - 127 - 220...240 V~ 50 Hz
Un	110 - 120...127 - 220...240 V~ 60 Hz
Operating limits	- circuit-breaker opening: 35-70% Un - circuit-breaker closing: 85-110% Un
Power on inrush (Ps)	DC 200 W; AC = 200 VA
Inrush duration	approx. 100 ms
Continuous power (Pc)	DC = 5 W; AC = 5 VA
Opening time	60...80 ms
Insulation voltage	2000 V 50 Hz (for 1 min)

5a Electronic time delay device (-KT)



The electronic time delay device must be mounted externally in relation to the circuit-breaker. It allows release trip delay with established and adjustable times.

The use of the undervoltage release is recommended in order to prevent trips when the power supply network of the release may be subject to cuts or voltage drops of short duration.

If it is not supplied, circuit-breaker closing is disabled.

The time delay device must be combined with an undervoltage release for d.c.

Rated voltage of the undervoltage release must be within the selected range of working of the time-delay device.

Characteristics of the time-delay device

Un	24...30 - 48 - 60 - 110...127 - 220...250 V-
Un	48 - 60 - 110...127 - 220...240 - V~ 50/60 Hz
Adjustable opening time (release + time delay device): 0.5-1-1.5-2-3 sec	

6 Undervoltage release mechanical override



This is a mechanical device which allows the undervoltage release trip to be temporarily excluded.

It is always fitted with electrical signalling.

Should the application of this accessory be required, specify the request at the time of order since subsequent application by the customer is not possible.

2. Selection and ordering

Optional accessories

7 Circuit-breaker auxiliary contacts (-BB1; -BB2; -BB3)



Electrical signalling of circuit-breaker open/closed can be provided with a set of 15 auxiliary contacts as an alternative to the 10 provided as standard.

Note

With the group of ten auxiliary contacts supplied as standard and the maximum number of electrical applications, three break contacts (signalling circuit-breaker open) and five make contacts (signalling circuit-breaker closed) are available. With the group of 15 auxiliary contacts, according to the electrical applications required, the following are available:

- for fixed circuit-breakers: thirteen auxiliary contacts, differently divided between break contacts and make contacts according to the figure selected of the electrical diagram;
- for withdrawable circuit-breakers, since the plug of the auxiliary circuits has a limited number of poles: five break contacts (signalling circuit-breaker open) and five make contacts (signalling circuit-breaker closed).

General characteristics

Insulation voltage according to VDE 0110 standard. Group C	660 V a.c. 800 V d.c.
Rated voltage	24 V ... 660 V a.c.
Test voltage	2 kV 50 Hz (for 1 min)
Rated overcurrent	10 A
Number of contacts	5
Contact run	6 mm ... 7 mm
Activation force	26 N
Resistance	3 mΩ
Storage temperature	-20 °C ... +120 °C
Operating temperature	-20 °C ... +70 °C
Contact overtemperature	20 K
Number of cycles	30.000
Unlimited breaking capacity if used with 10 A fuse in series	

Electrical characteristics

Un		Rated current	Breaking capacity
220 V a.c.	Cosφ = 0.7	2.5 A	25 A
380 V a.c.	Cosφ = 0.7	1.5 A	15 A
500 V a.c.	Cosφ = 0.7	1.5 A	15 A
660 V a.c.	Cosφ = 0.7	1.2 A	12 A
24 V d.c.	1 ms	10 A	12 A
	15 ms	10 A	12 A
	50 ms	8 A	10 A
	200 ms	6 A	7.7 A
60 V d.c.	1 ms	8 A	10 A
	15 ms	6 A	8 A
	50 ms	5 A	6 A
110 V d.c.	200 ms	4 A	5.4 A
	1 ms	6 A	8 A
	15 ms	4 A	5 A
220 V d.c.	50 ms	2 A	4.6 A
	200 ms	1 A	2.2 A
	1 ms	1.5 A	2 A
220 V d.c.	15 ms	1 A	1.4 A
	50 ms	0.75 A	1.2 A
	200 ms	0.5 A	1 A

8 Transient contact (-BB4)



This contact closes momentarily (duration > 30 ms) on circuit-breaker opening controlled remotely with a shunt opening release.

The indication is not provided when opening is manual and local. In fact, a contact (-BB11) is activated by the manual pushbutton and cuts off the transient contact closure (-BB4). The transient contact is activated directly from the main operating shaft when the indication is provided only on actual opening of the main circuit-breaker contacts.

9 Position contact (-BT3)



This contact is used, together with the locking magnet in the operating mechanism (-RL1) to prevent remote closing during traverse into the unit.

It is only supplied for the withdrawable version circuit-breakers for UniGear ZS1 switchgear and PowerCube modules. It cannot be supplied when the transmitted contacts are requested in the truck (-BT1; -BT2).

10 Transmitted contacts in the truck (-BT1; -BT2)



Transmitted contacts of the withdrawable circuit-breaker (installed in the circuit-breaker truck - only for VD4/P withdrawable circuit-breaker).

These contacts are either in addition or as an alternative to the position contacts (for signalling circuit-breaker racked out) located in the unit. They also carry out the function of the position contact (-BT3).

2. Selection and ordering

Optional accessories

11 Motor operator (-MS)



This carries out automatic charging of the circuit-breaker operating mechanism closing spring. After circuit-breaker closing, the geared motor immediately recharges the closing springs.

In the case of a power cut or during maintenance work, the closing spring can be charged manually in any case (by means of the special crank handle incorporated in the operating mechanism).

12 Contact for signalling closing spring charged/ discharged (-BS2)



This consists of a microswitch which allows remote signalling of the state of the circuit-breaker operating mechanism closing spring.

The following signals are possible:

- contact open: signalling spring charged
- contact closed: signalling spring discharged.

The two signals must be used for circuits which have the same power supply voltage.

Characteristics

Un	24...30 - 48...60 - 110...130 - 220...250 V-	
Un	100...130 - 220...250 V- 50/60 Hz	
Operating limits	85 ... 110% Un	
Power on inrush (Ps)	≤ 40 kA	50 kA (*)
	DC = 600 W; AC = 600 VA	DC = 900 W; AC = 900 VA
Rated power (Pn)	DC = 200 W; AC = 200 VA	DC = 350 W; AC = 350 VA
	Charging time	0,2 s
Charging time	6-7 s	6-7 s
Insulating voltage	2000 V 50 Hz (for 1 min)	2000 V 50 Hz (for 1 min)

(*) Not available for versions with motorized truck.

Protections and locks

Various mechanical and electromechanical locking and protection devices are available.

13 Opening and closing pushbutton protection



The protection only allows the opening and closing pushbuttons to be operated using a special tool.

14 Opening and closing pushbutton padlock

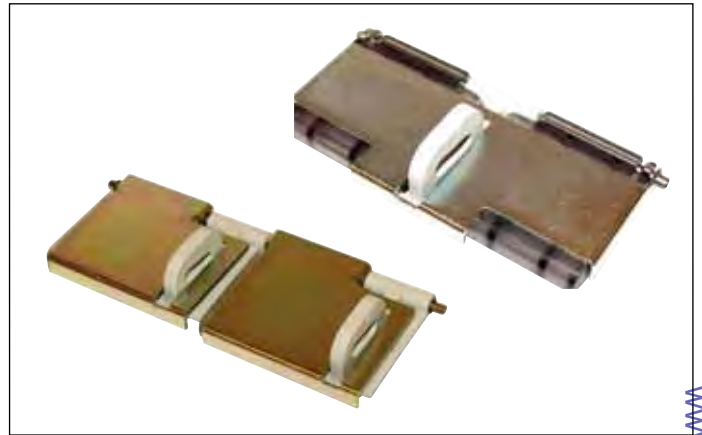

The device allows the opening and closing pushbuttons to be locked using a maximum of three padlocks (not supplied); \varnothing 4 mm. Also prevents closing using remote control.

This lock is available in two versions:

- 14A** Possibility of padlocking both the pushbuttons without distinction
- 14B** Separate padlocking of the opening and/or closing pushbutton.

N.B. Lock 14A prevents closure by remote control; lock 14B does not prevent closure by remote control.

2. Selection and ordering

Optional accessories

15 Key lock in open position



The lock is activated by a special circular lock. Different keys (for a single circuit-breaker) are available, or the same keys (for several circuit-breakers). To activate the lock, keep the opening pushbutton pressed down, turn the key and remove it. With the key removed, the opening pushbutton automatically remains in the pressed position preventing local manual closing and remote electrical closing.

16 Locking magnet on the operating mechanism (-RL1)



Only allows activation of the command with the electromagnet supplied.

Characteristics

Un	24 - 30 - 48 - 60 - 110 - 132 - 220 - 250 V~
Un	48 - 60 - 110 - 120 ... 127 - 220 ... 240 V~ 50/60 Hz
Operating limits	85 ... 110% Un
Power on inrush (Ps)	DC 250 W; AC = 250 VA
Continuous power (Pc)	DC = 5 W; AC = 5 VA
Inrush duration	150 ms
Insulating voltage	2000 V 50 Hz (for 1 min)

17 Locking magnet on the truck (-RL2)



Compulsory accessory for the withdrawable versions for UniGear ZS1 switchgear and PowerCube modules, to prevent circuit-breaker racking into the switchgear with the auxiliary circuit plug disconnected.

The plug also makes the anti-insertion lock for a different rated current. Special striker pins do not allow insertion of the plug in the socket if the rated current of the circuit-breaker is lower than the rated current of the panel.

Note: on request, a specific version for the circuit-breakers for ZS8.4 switchgear is available.

Characteristics	
Un	24 - 30 - 48 - 60 - 110 - 125 - 127 - 132 - 220 - 240 V-
Un	24 - 30 - 48 - 60 - 110 - 125 - 127 - 220 - 230 ... 240 V- 50/60 Hz
Operating limits	85 ... 110% Un
Nominal power (Pn)	DC 250 W; AC = 250 VA
Continuous power (Pc)	DC = 5 W; AC = 5 VA
Inrush duration	150 ms
Insulating voltage	2000 V 50 Hz (for 1 min)

18 Interlock for fixed circuit-breaker



Device for fixed circuit-breakers which are converted into withdrawable ones by the customer. It allows a mechanical lock to be made, by the customer, which prevents racking-out/in with the circuit-breaker closed and prevents circuit-breaker closing during translation.

Note: The device must be requested when ordering since it must be assembled and tested in the factory.

2. Selection and ordering Optional accessories

19 Mechanical interlock with the door



This device prevents circuit-breaker racking-in when the switchgear door is open. It is only provided for circuit-breakers used in switchgear UniGear ZS1 and PowerCube modules, fitted with a special actuator on the door.

20 Motorised truck (-MT)

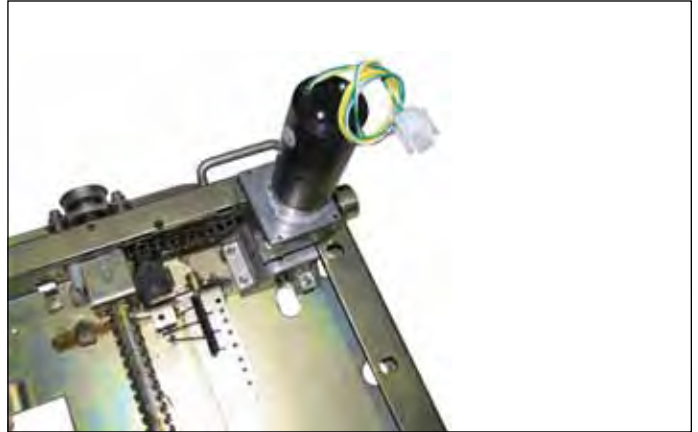

It allows racking-in and racking-out of the circuit-breaker in the switchgear to be carried out remotely, (only for circuit-breaker in withdrawable version for UniGear ZS1 and ZS8.4 switchgear and PowerCube modules).

Characteristics

Un	24 - 30 - 48 - 60 - 110 - 220 V-
Operating limits	85 ... 110% Un
Nominal power(Pn)	40 W

21 STU Shunt Test Unit



Due to the particular construction of these releases, checking the functionality of the shunt closing (-MC) and opening (-MO1, -MO2) releases is not possible with dedicated relays (e.g. TCS Test Control Supervision, CCC Control Coil Continuity) or with the REF control and protection unit. The only device able to carry out a check of the functionality is the STU device. Please contact us if you want to carry out this control with devices other than STU.

This device can be combined with the shunt opening release **(-MO1; -MO2)** or with the shunt closing release **(-MC)** to check functionality and continuity.

The control/monitoring Shunt Test Unit allows the continuity of releases with a rated operating voltage between 24 V and 250 V (AC and DC) to be checked, as well as the functionality of the electronic circuit of the release.

Checking continuity is carried out cyclically with an interval of 20 seconds between one test and the next.

The unit has optical signals by means of LEDs on the front. In particular the following information is indicated:

- POWER ON: power supply present
- (-MO) TESTING: test being carried out
- TEST FAILED: signal following a failed test or in the absence of auxiliary power supply
- ALARM: signal after three failed tests.

Two relays and a changeover are also available on board the unit, which allow remote signalling of the following two events:

- failure of a test (resetting is carried out automatically when the alarm stops)
- failure of three tests (resetting is only carried out by means of the manual - RESET – from the front of the unit).

There is also a manual - RESET – button on the front of the unit.

Characteristics

Un	24 ... 250 V AC/DC
Maximum interrupted current	6 A
Maximum interrupted voltage	250 V AC

3. Specific product characteristics

Resistance to vibrations



The VD4 circuit-breakers are designed to satisfy high levels of resistance to stresses caused by mechanical vibrations. Many versions are able to satisfy both the approval criteria of the major International Shipping Registers (DNV, Lloyd's Register, RINA) and the qualification criteria of the International Seismic Standards (IEEE 344, IEEE 323 and IEC 60980). For the versions approved by the shipping registers, please contact us.

Tropicalization



VD4 circuit-breakers are manufactured in compliance with the strictest regulations regarding use in hot-humid-saline climates. All the most important metal components are treated against corrosive factors according to UNI EN 12500 Standards environmental class C.

Galvanisation is carried out in accordance with UNI ISO 2081 Standards, classification code Fe/Zn 12, with a thickness of 12×10^{-6} m, protected by a conversion layer mainly consisting of chromates in compliance with the UNI ISO 4520 Standard. These construction characteristics mean that the whole VD4 series of circuit-breakers and its accessories comply with climate graph 8 of the IEC 60721-2-1 and IEC 60068-2-2 (Test B: Dry Heat / IEC 60068-2-30 (Test Db: Damp Heat, cyclic) Standards.

Altitude



The insulating property of air decreases as the altitude increases, therefore this must always be taken into account for external insulation of the apparatus (the internal insulation of the interrupters does not undergo any variations as it is guaranteed by the vacuum). The phenomenon must always be taken into consideration during the design stage of the insulating components of apparatus to be installed over 1000 m above sea level. In this case a correction coefficient must be considered, which can be taken from the graph on the next page, built up on the basis of the indications in the IEC 62271-1 Standards. The following example is a clear interpretation of the indications given above.

Graph for determining the Ka correction factor according to the altitude

Example

- Installation altitude 2000 m
- Operation at the rated voltage of 12 kV
- Withstand voltage at power frequency 28 kV rms
- Impulse withstand voltage 75 kVp
- Ka factor obtained from graph = 1.13.

Considering the above parameters, the apparatus will have to withstand (under test and at zero altitude, i.e. at sea level):

- withstand voltage at power frequency equal to:
28 x 1.13 = 31.6 kVrms
- impulse withstand voltage equal to:
75 x 1.13 = 84.7 kVp.

From the above, it can be deduced that for installations at an altitude of 2000 m above sea level, with 12 kV service voltage, apparatus must be provided with 17.5 kV rated voltage, characterised by insulation levels at power frequency of 38 kVrms with 95 kVp impulse withstand voltage.

- H** = altitude in metres;
- m** = value referred to power frequency and the lightning impulse withstand voltages and those between phases.

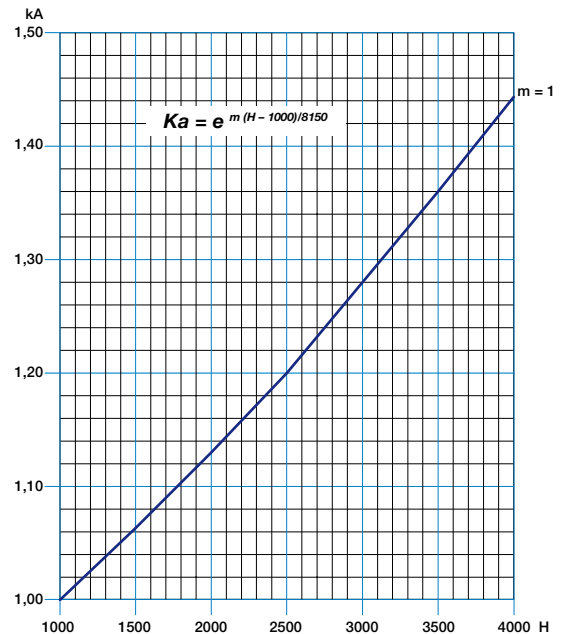

Anti-pumping device

The EL operating mechanism of VD4 circuit-breakers (in all versions) is fitted with a mechanical anti-pumping device which prevents re-closing due to either electrical or mechanical commands.

Should both the closing command and any one of the opening commands (local or remote) be active at the same time, there would be a continuous succession of opening and closing commands.

The anti-pumping device avoids this situation, ensuring that each closing operation is only followed by an opening operation and that there is no other closing operation after this. To obtain a further closing operation, the closing command must be released and then re-launched.

Furthermore, the anti-pumping device only allows circuit-breaker closure if the following conditions are present at the same time:

- operating mechanism spring fully charged
- opening pushbutton and/or shunt opening release (-MO1/-MO2) not activated
- circuit-breaker open.

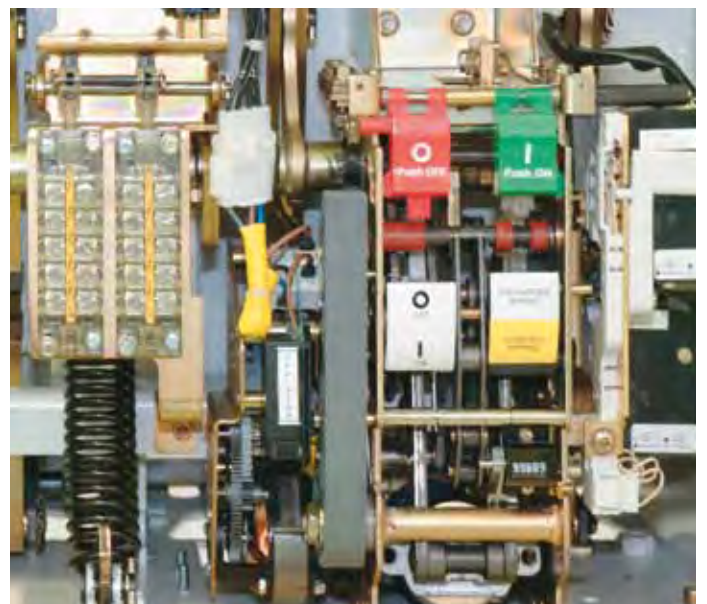

3. Specific product characteristics

REF 601 protection Device



On request, the REF 601 switchgear protection device is available for protection of the installations, which requires an auxiliary power supply for its operation unlike the previous PR512 which was a self-supplied release.

The REF 601 has protections and trip curves in accordance with the IEC 255-3 Standard. It sees to the protection function against overload (51), against instantaneous and delayed short-circuit (50-51) and against instantaneous and delayed homopolar ground fault (50N and 51N). It also detects the second harmonic component to prevent unwarranted tripping on connection of a transformer (68).

The unit has 3 inputs from current sensors of the type with Rogowsky coil, one input from external toroidal CT and from the keyboard 4 rated currents can be set: 40, 80, 250 and 1250 A.

If the unit is connected to 3 current sensors, the 50N and 51N protection functions are carried out with the vectorial sum of the phase currents; if only 2 current sensors are used, then the external toroidal current transformer must be provided for functions 50N and 51N.

The external toroidal current transformer can be with openable core or closed and with any transformation ratio as long with a 1 A secondary current.

The ABB current sensors of the type with Rogowsky coil provided for REF 601, are only suitable for installation on MV insulated cables.

The characteristics of the device are:

- trip precision
- wide adjustment ranges
- single and simultaneous adjustment of the three phases
- no limitation (due to the current sensors) to the rated breaking capacity and at the short-time withstand current of the circuit-breaker
- pushbuttons for local electrical operation of the circuit-breaker (opening and closing pushbutton)
- 5 distinct indicators: "relay in operation", "relay in trip threshold", "relay tripped", "relay tripped due to exceeding phase current", "relay tripped due to exceeding ground fault current"
- interface consisting of an LCD display and of "arrow" keys, "enter" and "esc" for easier navigation inside the "measurement", "data recording", "event recording", "settings", "configuration" and "test" menus
- three user levels: "operator" (only display, with free access, by keeping this key pressed for at least 5 sec.), "configurator" (like the previous one, but also with permission to set the protection parameters, i.e. times and thresholds, and communication, if present - access limited by a password), "administrator" (like the previous ones, but also with permission to set the password and configure the basic settings of the device, such as the rated current - access limited by a password)
- continual display of the current on the most highly loaded phase and of the round current
- recording of the value of the currents which caused the device to trip
- storage of the number of openings carried out by the device
- event log (storage of the parameters described above in the last 5 trips of the device) in a non-volatile memory
- curves " $\beta = 1$ " or " $\beta = 5$ " and curve "RI" specific for the Belgian market (only REF 601 IEC)
- circuit-breaker opening by means of an undervoltage release (only REF 601 CEI)
- version, on request, with RS485 4-wire serial communication
- MODBUS RTU full duplex protocol
- multi-voltage feeder 24 ... 240 V a.c.- d.c

Environmental protection programme

VD4 circuit-breakers are manufactured in accordance with the ISO 14000 Standards (Guidelines for environmental management).

The production processes are carried out in compliance with the Standards for environmental protection in terms of reduction in energy consumption as well as in raw materials and production of waste materials. All this is thanks to the medium voltage apparatus manufacturing facility environmental management system.

Assessment of the environmental impact of the life cycle of the product, obtained by minimising energy consumption and overall raw materials of the product, became a concrete matter during the design stage by means of targeted selection of the materials, processes and packing.

This is to allow maximum recycling at the end of the useful life cycle of the apparatus.

Spare parts

- Shunt opening release
- Additional shunt opening release
- Undervoltage release
- Time delay device for undervoltage release
- Shunt closing release
- Spring charging geared motor with electrical signalling of spring charged
- Contact signalling geared motor protection circuit-breaker open/closed
- Contact signalling closing spring charged/discharged
- Transient contact with momentary closing during circuit-breaker opening
- Circuit-breaker auxiliary contacts
- Locking electromagnet on the operating mechanism
- Position contact of the withdrawable truck
- Contacts signalling connected/isolated
- Opening solenoid
- Key lock in open position
- Isolation interlock with the door
- Protection for opening pushbutton
- Protection for closing pushbutton
- Locking electromagnet on the withdrawable truck
- Set of six isolating contacts.

Ordering

For availability and to order spare parts, please contact our Service department, specifying the circuit-breaker serial number.

4. Overall dimensions

Fixed circuit-breakers

VD4	
TN	1VCD000050
Ur	12 kV
	17.5 kV
I_r	1600 A
	20 kA
I_{sc}	25 kA
	31.5 kA

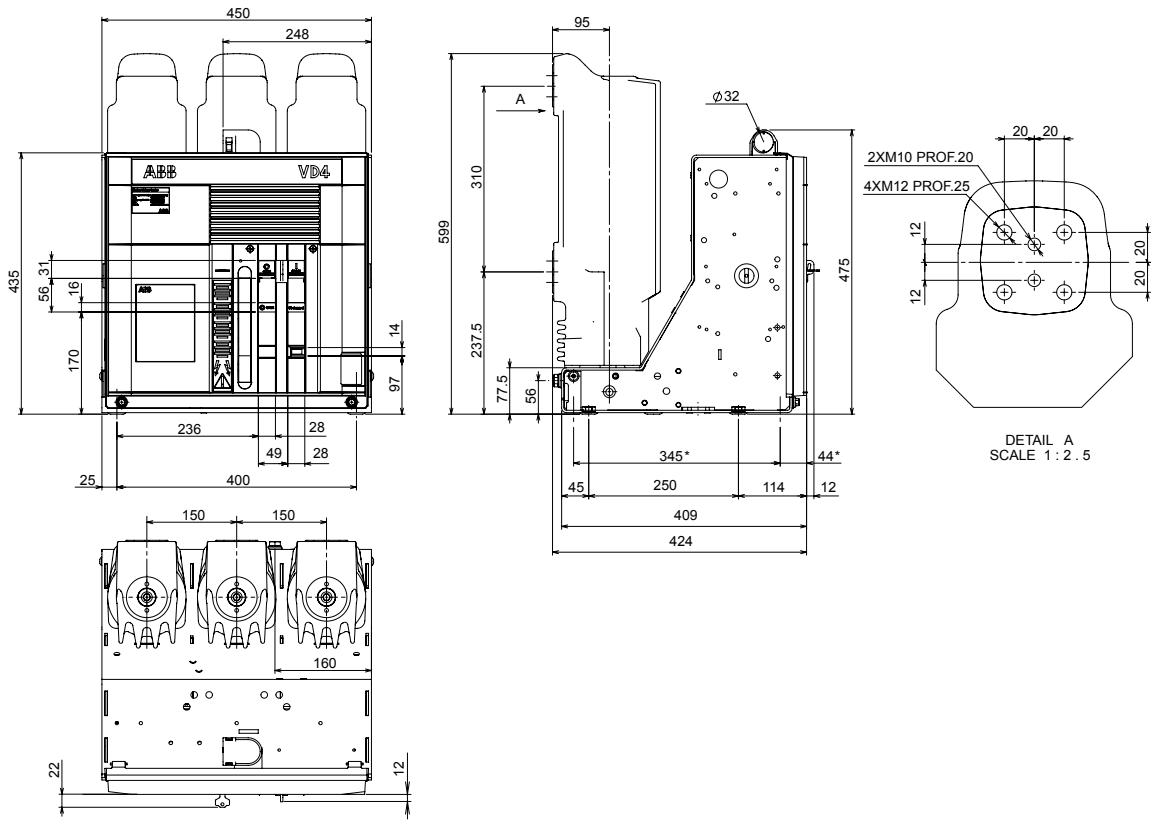

(*) Fixing interchangeability with previous series (345 x 400).

Fixed circuit-breakers

VD4	
TN	7405
Ur	12 kV
	17.5 kV
I_r	630 A
	1250 A
I_{sc}	16 kA
	20 kA
	25 kA
	31.5 kA

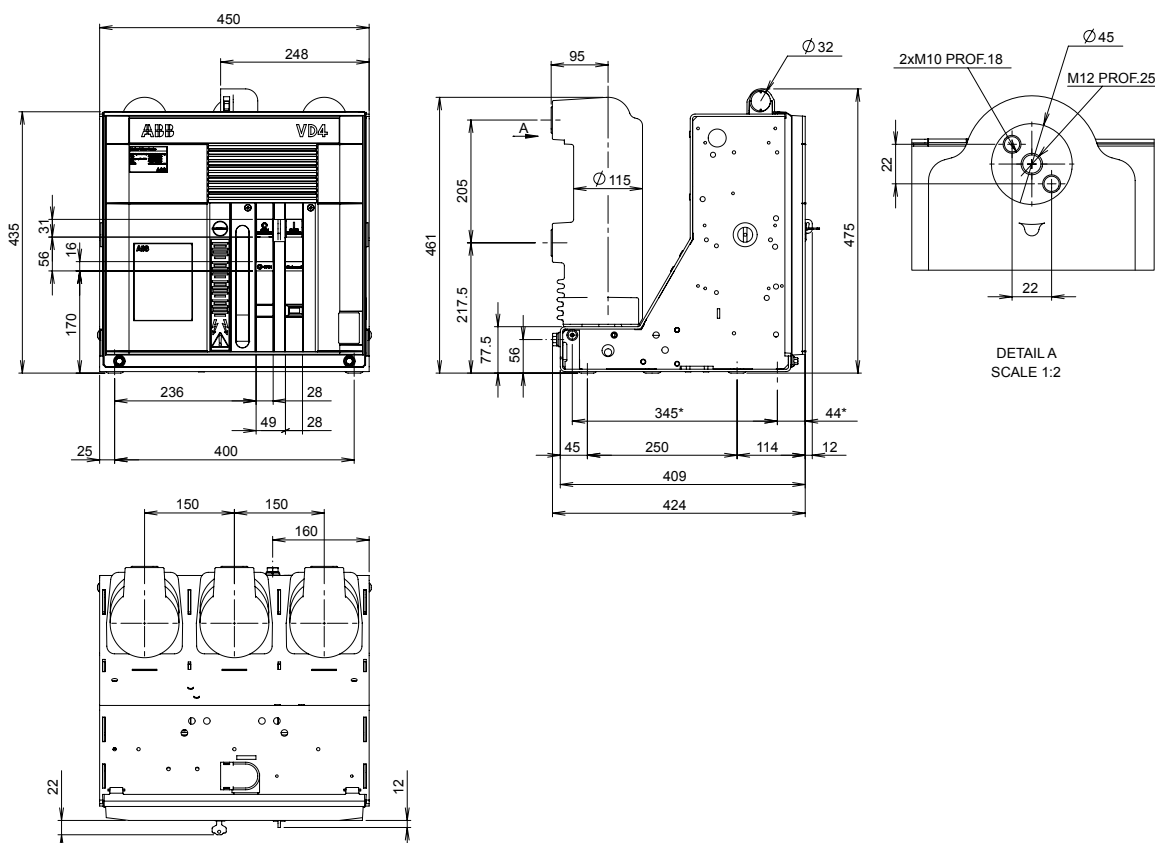

(*) Fixing interchangeability with previous series (345 x 400).

Fixed circuit-breakers

VD4	
TN	7406
Ur	12 kV
	17.5 kV
Ir	630 A
	1250 A
Isc	16 kA
	20 kA
	25 kA
	31.5 kA

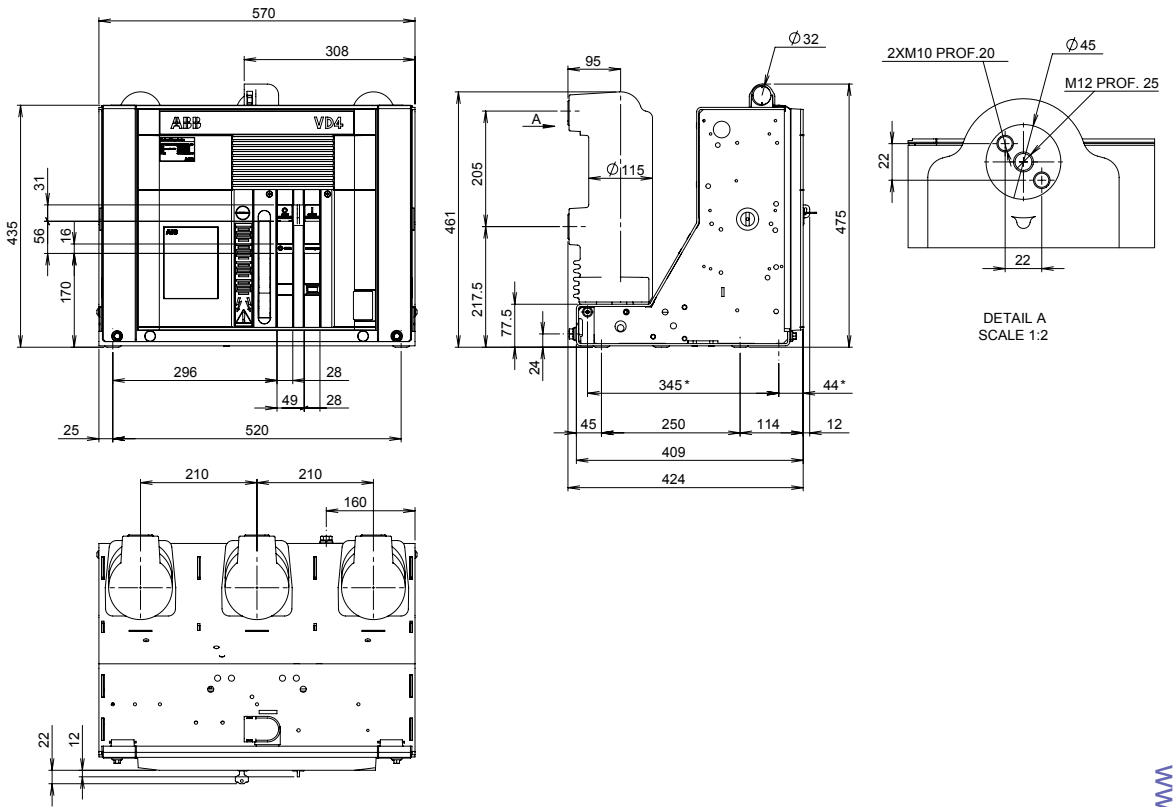

(*) Fixing interchangeability with previous series (345 x 520).

Fixed circuit-breakers

VD4	
TN	1VCD003282
Ur	12 kV
	17.5 kV
Ir	1250 A
	1600 A
Isc	40 kA

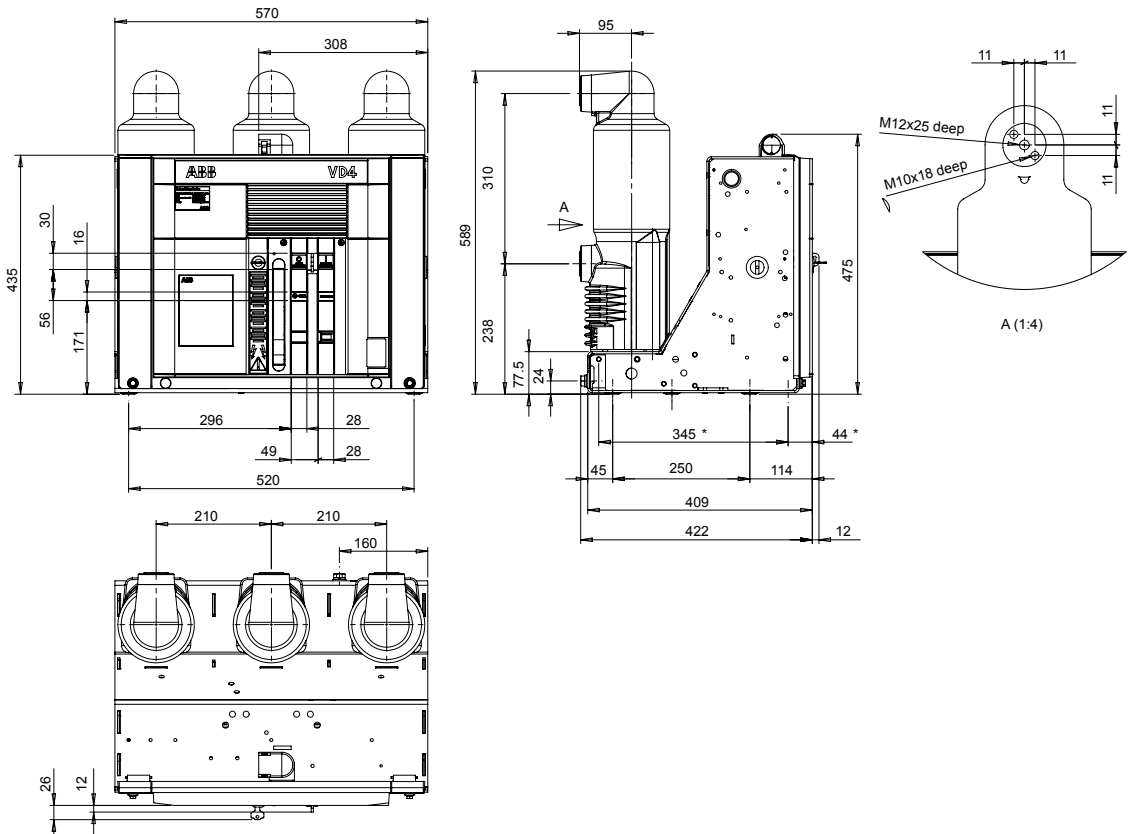

(*) Fixing interchangeability with previous series (345 x 650).

4. Overall dimensions

Fixed circuit-breakers

VD4	
TN	1VCD003285
Ur	12 kV
	17.5 kV
Ir	1250 A
	1600 A
Isc	40 kA

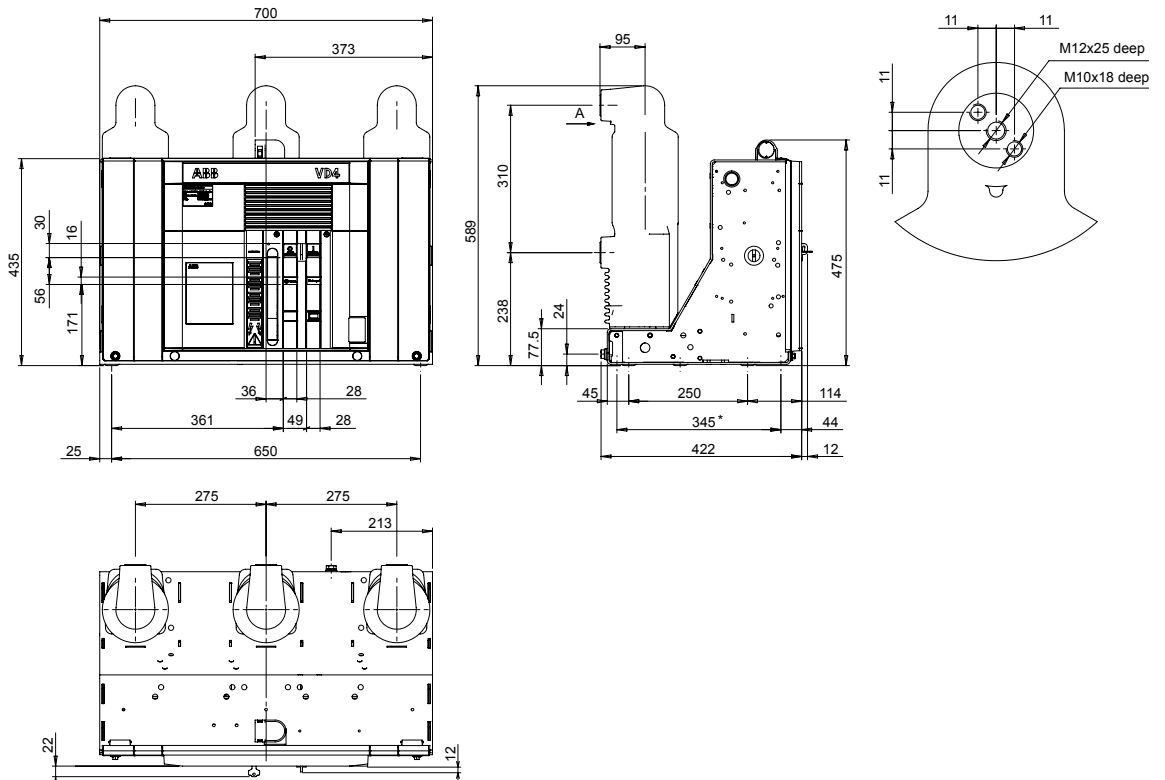

(*) Fixing interchangeability with previous series (345 x 650).

Fixed circuit-breakers

VD4	
TN	1VCD000051
Ur	12 kV
	17.5 kV
Ir	630 A
	1250 A
Isc	16 kA
	20 kA
	25 kA
	31.5 kA

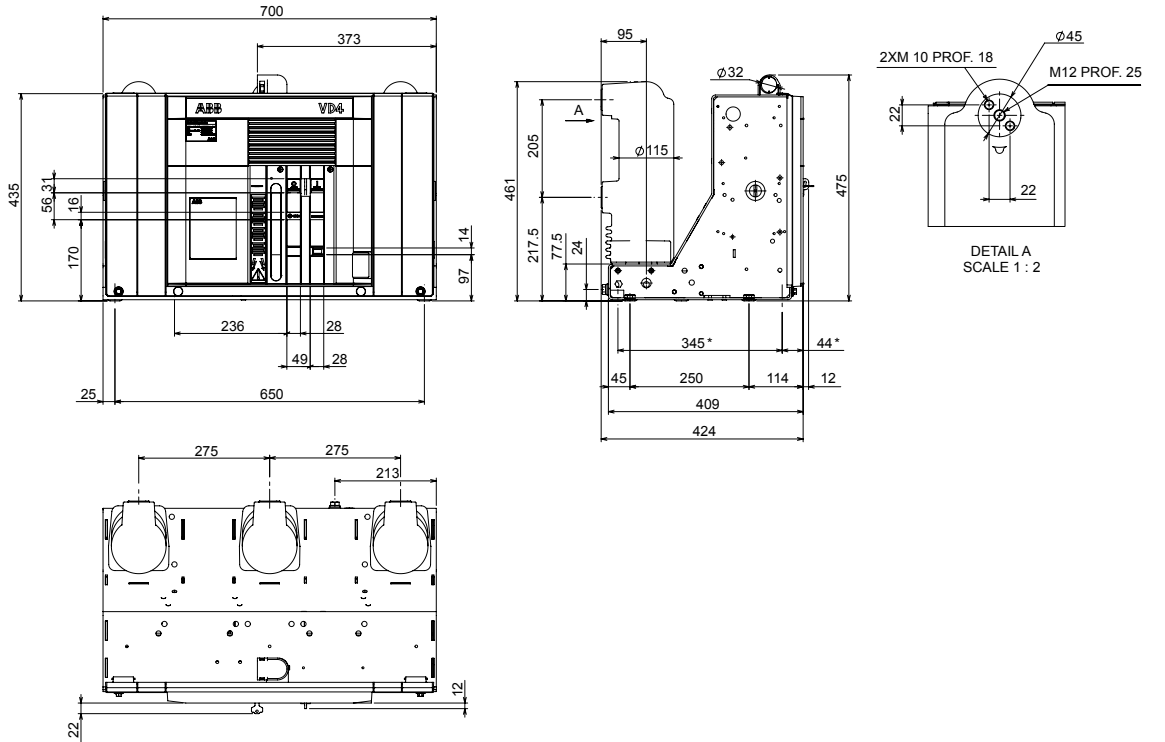

(*) Fixing interchangeability with previous series (345 x 650).

Fixed circuit-breakers

VD4	
TN	7408
Ur	12 kV
	17.5 kV
	1600 A
Ir	2000 A
	2500 A
	20 kA
Isc	25 kA
	31.5 kA

VD4	
TN	7408
Ur	12 kV
	17.5 kV
Ir	2000 A
	2500 A
Isc	40 kA

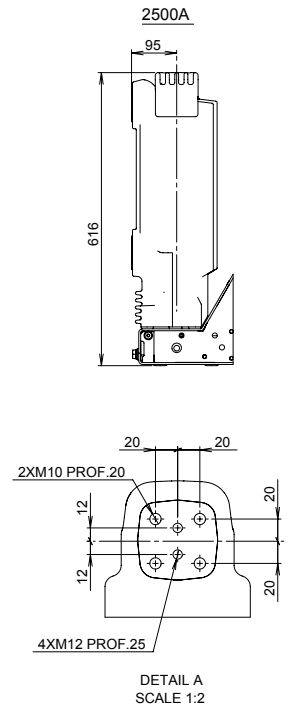
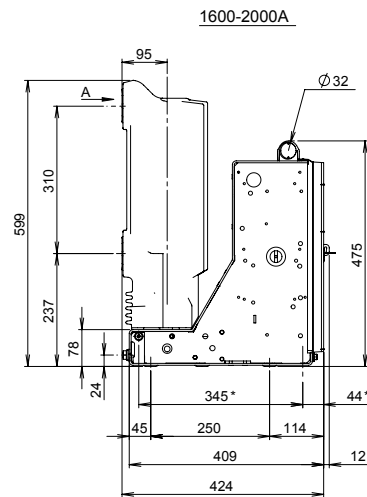
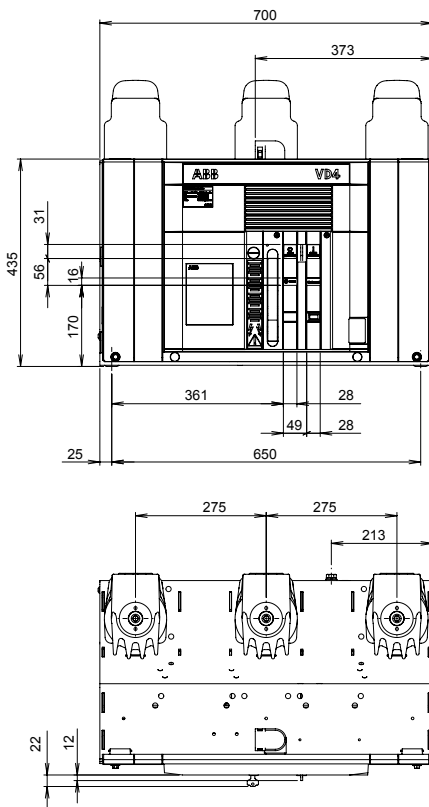

(*) Fixing interchangeability with previous series (345 x 650).

Fixed circuit-breakers

VD4	
TN	7407
Ur	12 kV
	17.5 kV
Ir	2500 A
	20 kA
	25 kA
Isc	31.5 kA
	40 kA

VD4	
TN	7407
Ur	12-17.5 kV
Ir	1600 A
	2000 A
	20 kA
	25 kA
Isc	31.5 kA
	40 kA

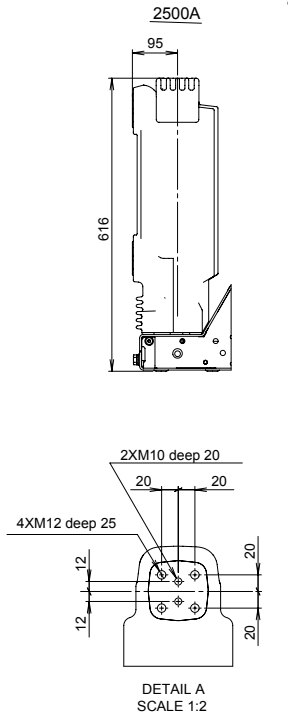
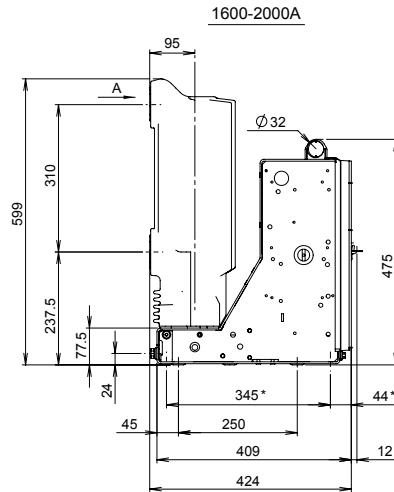
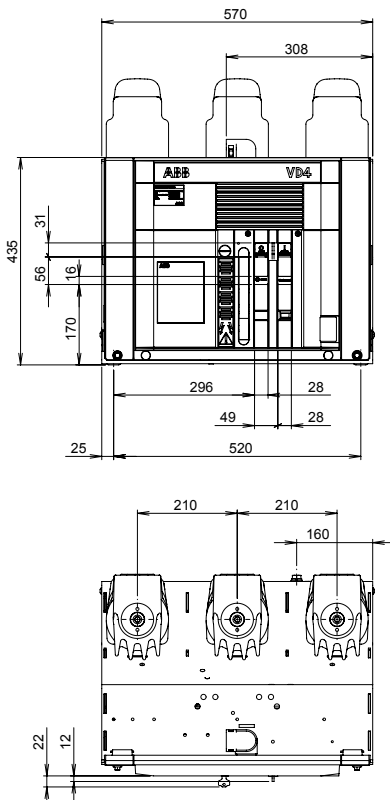

(*) Fixing interchangeability with previous series (345 x 650).

4. Overall dimensions

Fixed circuit-breakers

VD4	
TN	1VCD000149
Ur	12 kV
	17.5 kV
I_r	3150 A
	4000 A (**)
	20 kA
	25 kA
I_{sc}	31.5 kA
	40 kA
	50 kA

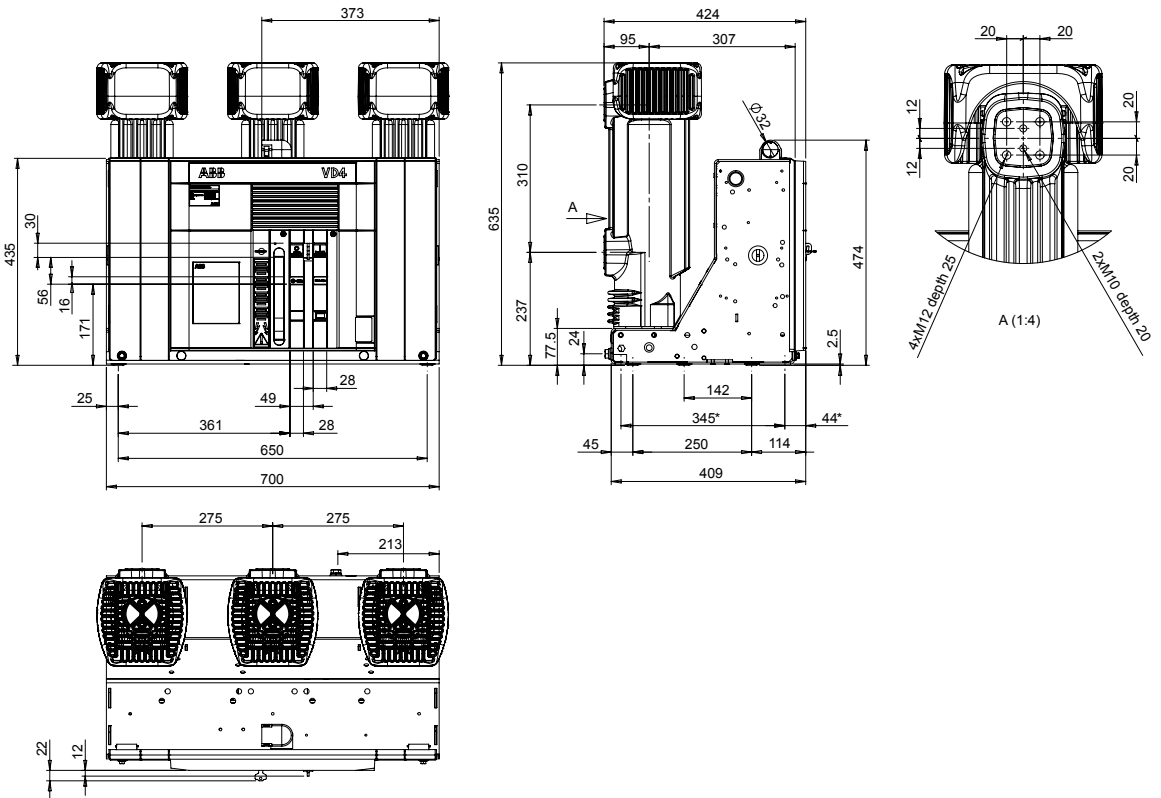

(*) Fixing interchangeability with previous series (345 x 650).
 (**) With forced ventilation.

Fixed circuit-breakers

VD4	
TN	1VCD003440
Ur	12 kV
	17.5 kV
I_r	1250 A
	1600 A
	2000 A
I_{sc}	50 kA

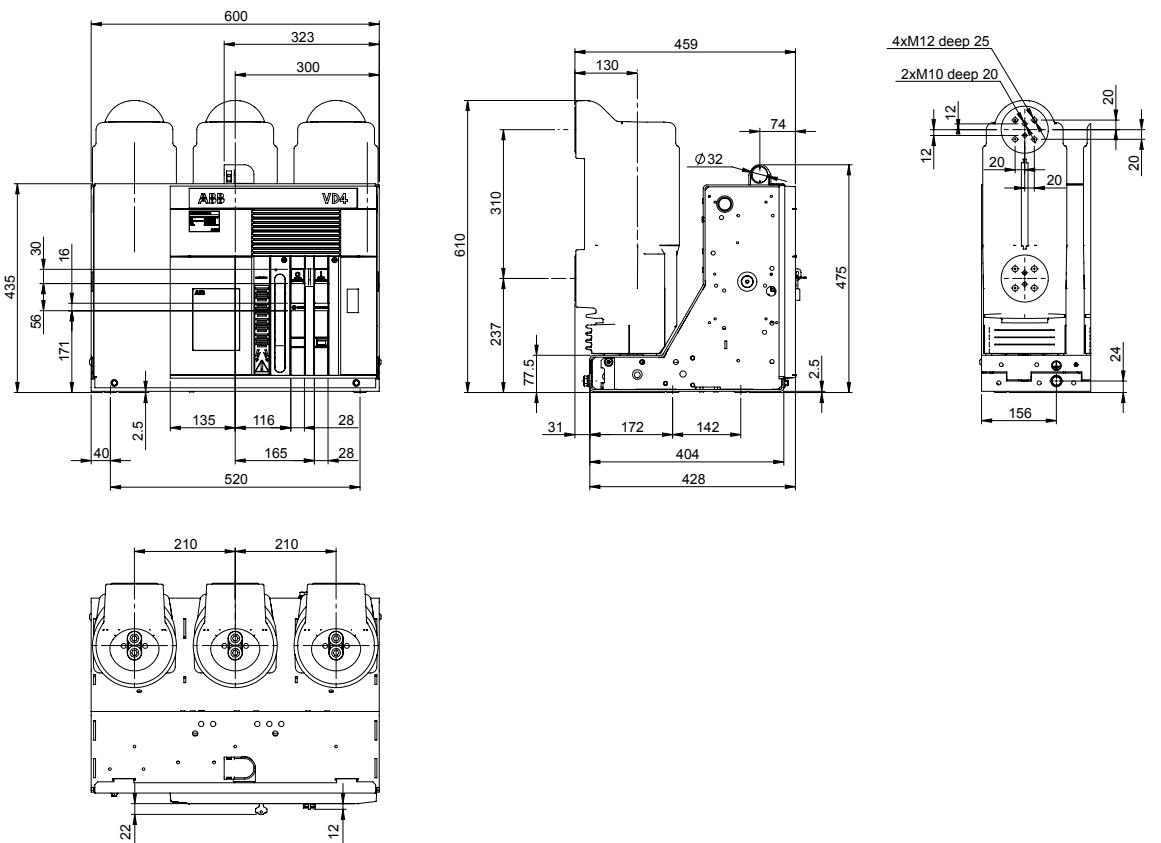

Fixed circuit-breakers

VD4	
TN	1VCD003441
Ur	12 kV
	17.5 kV
	1250 A
Ir	1600 A
	2000 A
	2500 A
Isc	50 kA

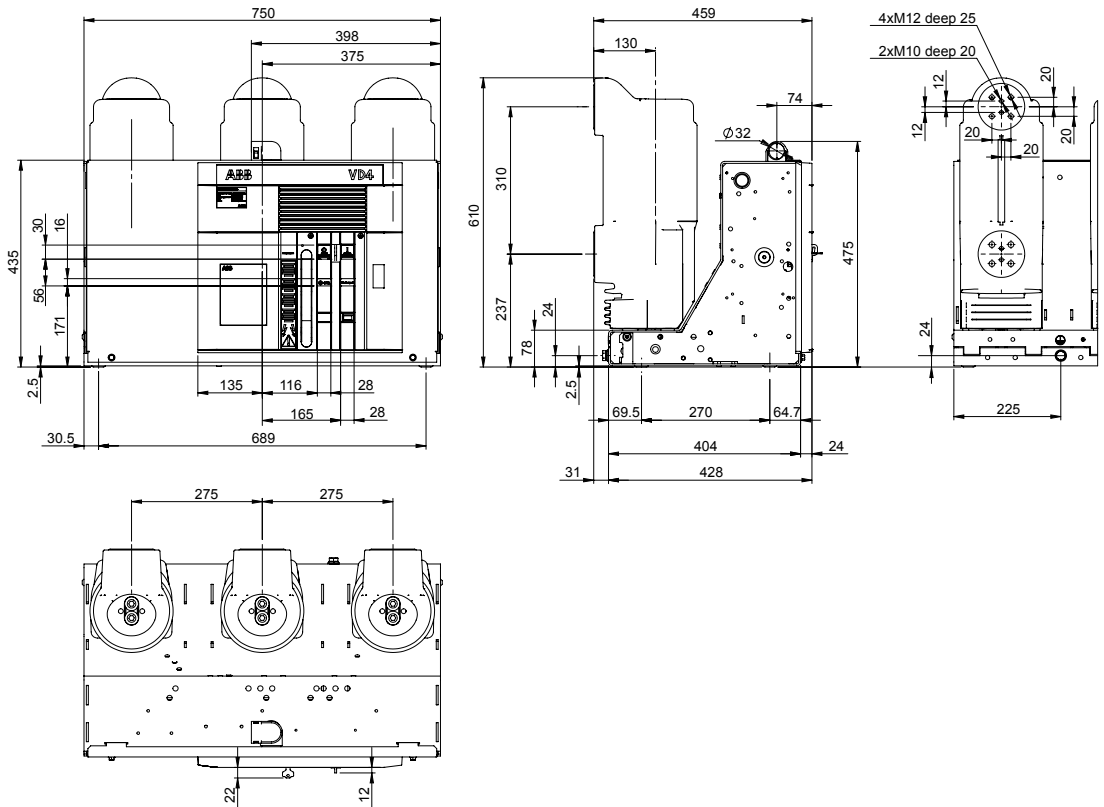

Fixed circuit-breakers

VD4	
TN	1VCD003443
Ur	12 kV
	17.5 kV
Ir	3150 A (*)
Isc	50 kA

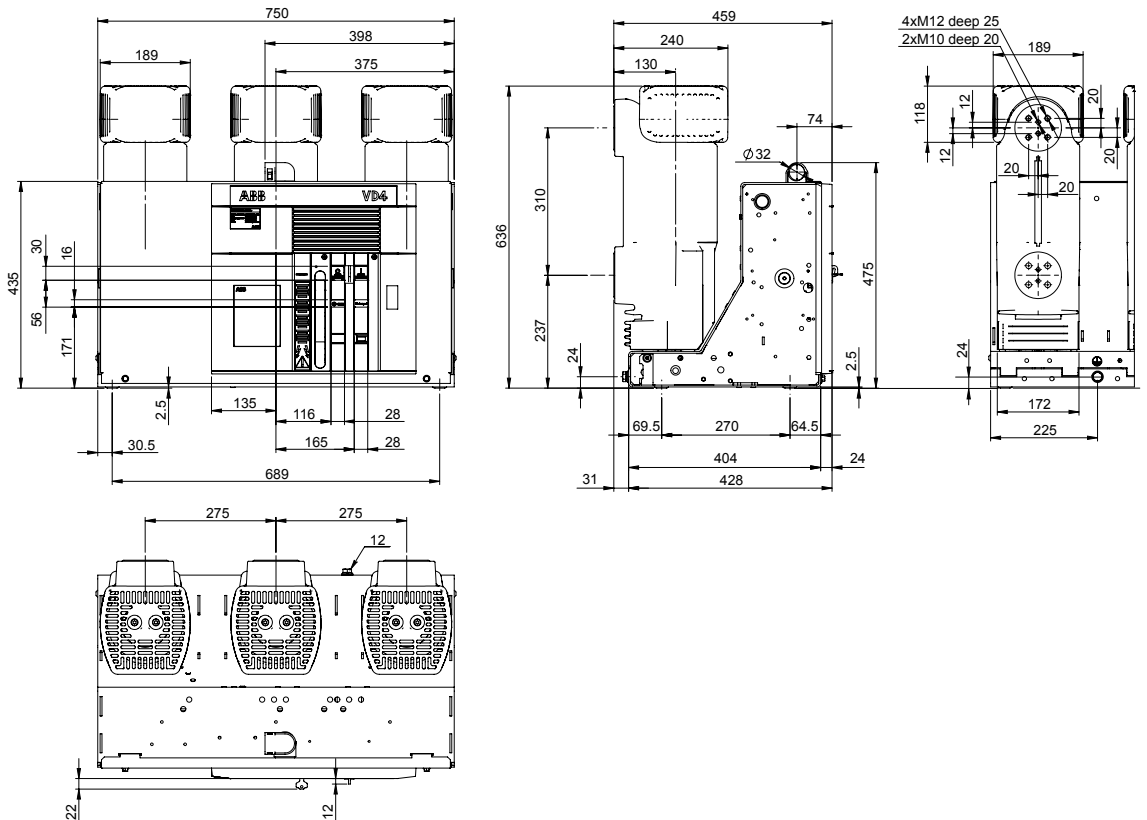

(*) 4000 A with forced ventilation.

4. Overall dimensions

Fixed circuit-breakers

VD4	
TN	7409
Ur	24 kV
Ir	630 A
	1250 A
Isc	16 kA
	20 kA
	25 kA

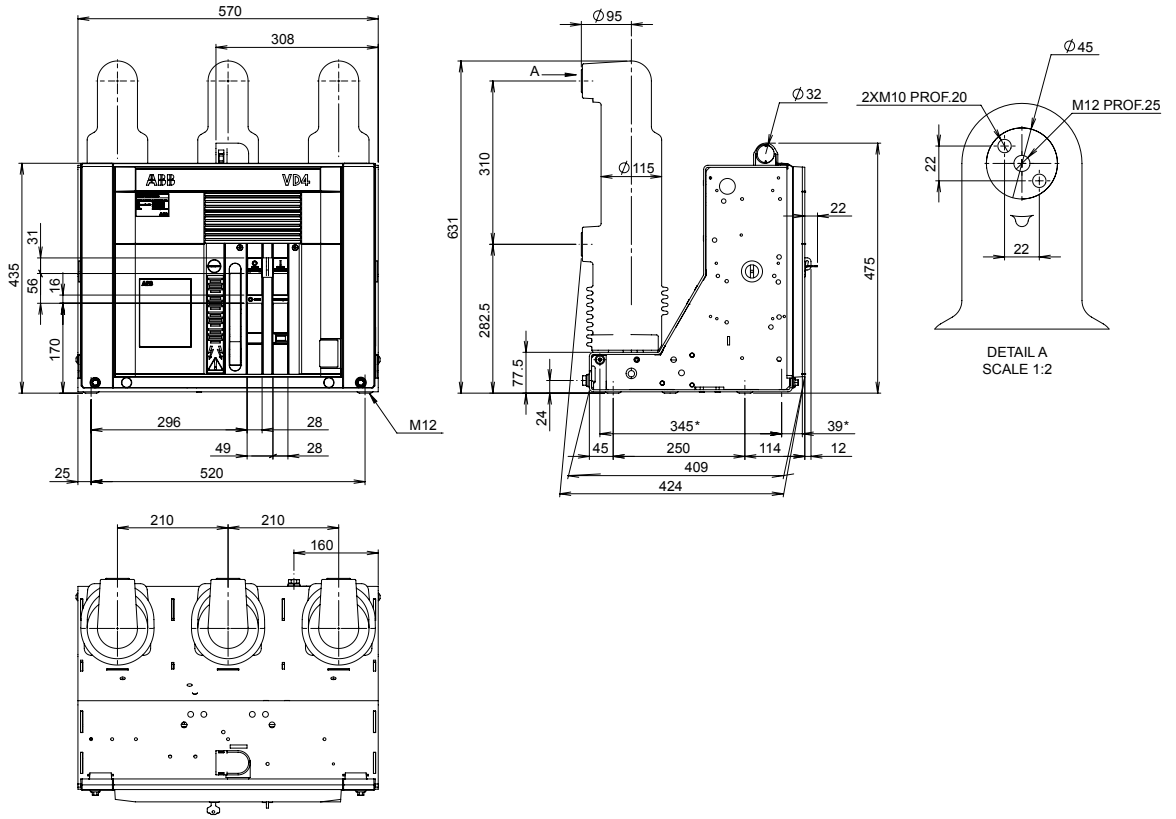

(*) Fixing interchangeability with previous series (345 x 520).

Fixed circuit-breakers

VD4	
TN	7410
Ur	24 kV
Ir	630 A
	1250 A
Isc	16 kA
	20 kA
	25 kA

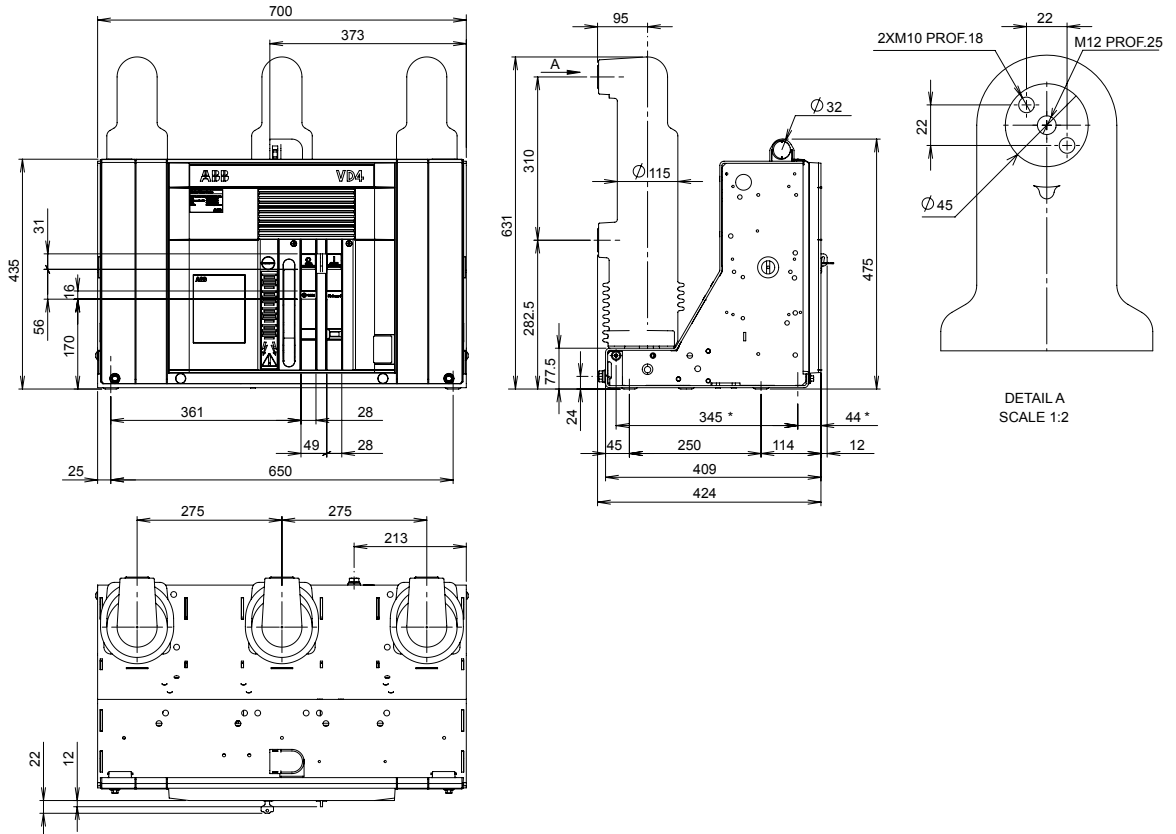

(*) Fixing interchangeability with previous series (345 x 650).

Fixed circuit-breakers

VD4	
TN	7411
Ur	24 kV
	1600 A
Ir	2000 A
	2500 A
	16 kA
Isc	20 kA
	25 kA
	31,5 kA

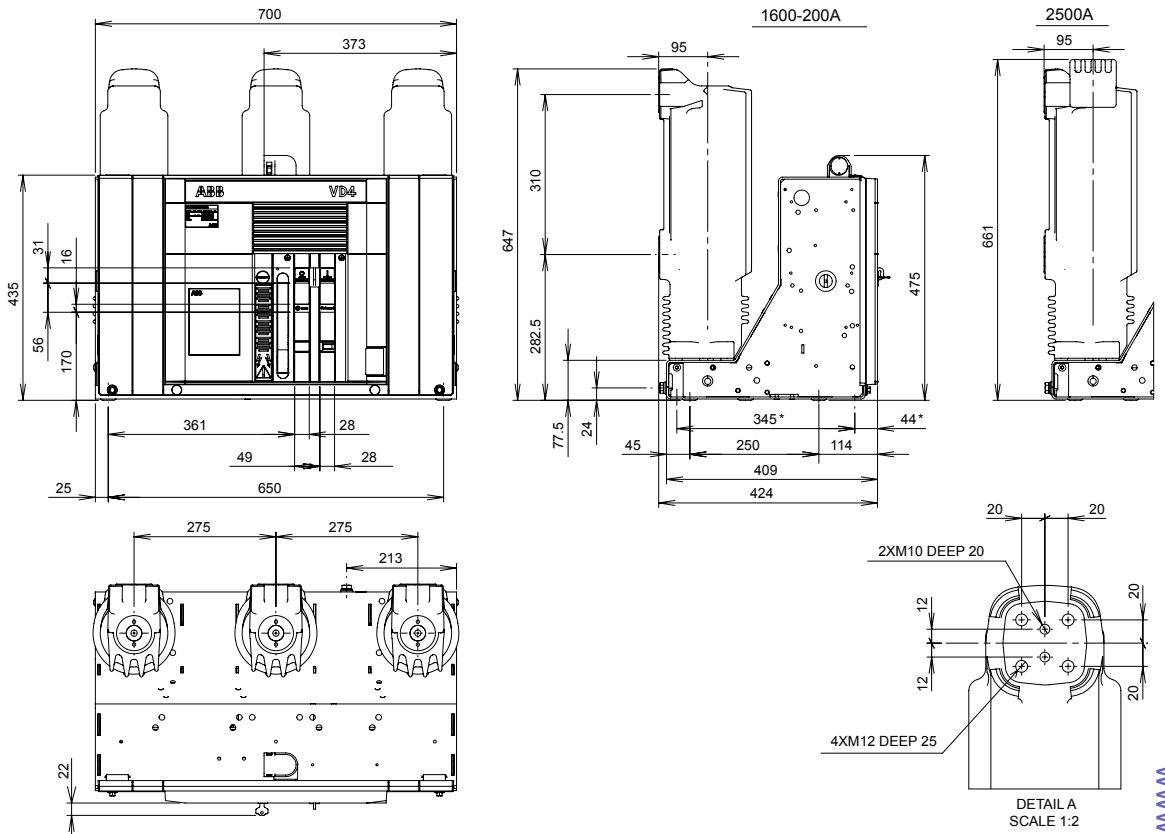

(*) Fixing interchangeability with previous series (345 x 650).

Fixed circuit-breakers

VD4	
TN	1VCD000172
Ur	24 kV
Ir	1250 A
Isc	31.5 kA

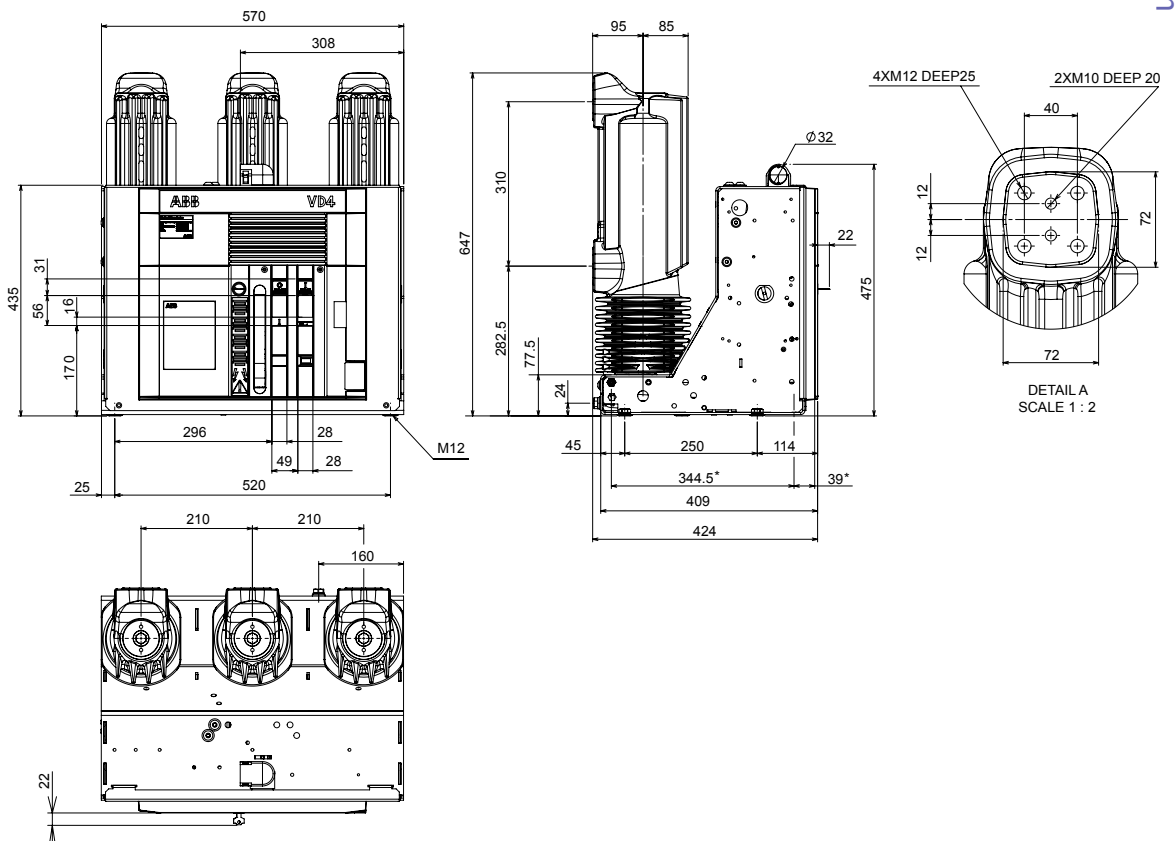

4. Overall dimensions

Fixed circuit-breakers

VD4	
TN	1VYN300901-LT
Ur	36 kV
	1250 A
Ir	1600 A
	2000 A
Isc	31.5 kA

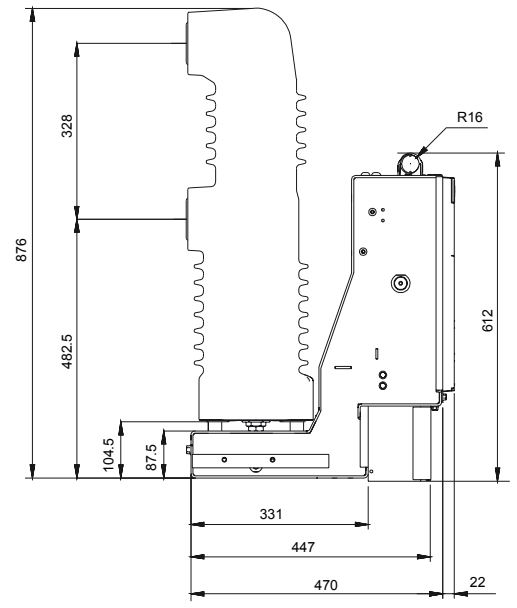
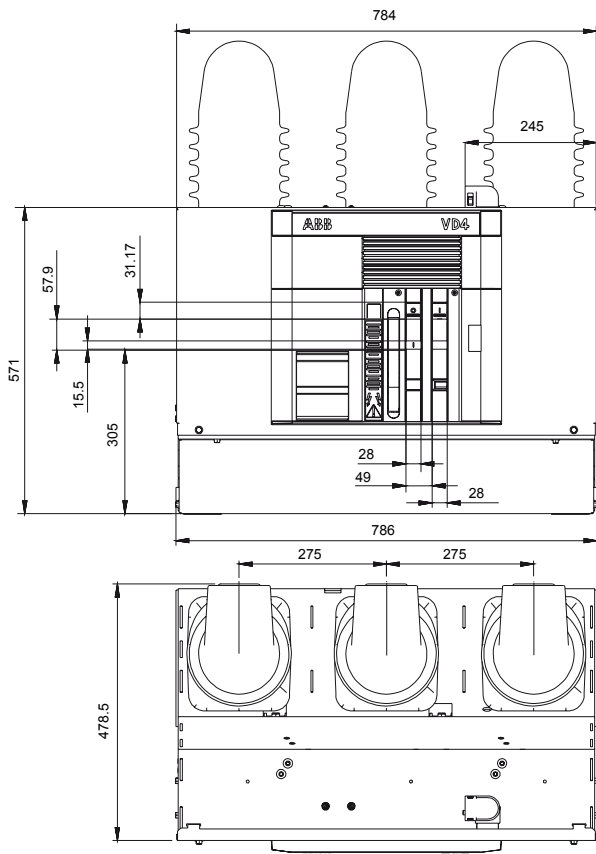

Provided by Northeast Power Systems, Inc.
www.nepsi.com

Withdrawable circuit-breakers for UniGear ZS1 switchgear and PowerCube modules

VD4/P	
TN	7412
Ur	12 kV
	17.5 kV
Ir	630 A
	1250 A
Isc	16 kA
	20 kA
	25 kA
	31.5 kA

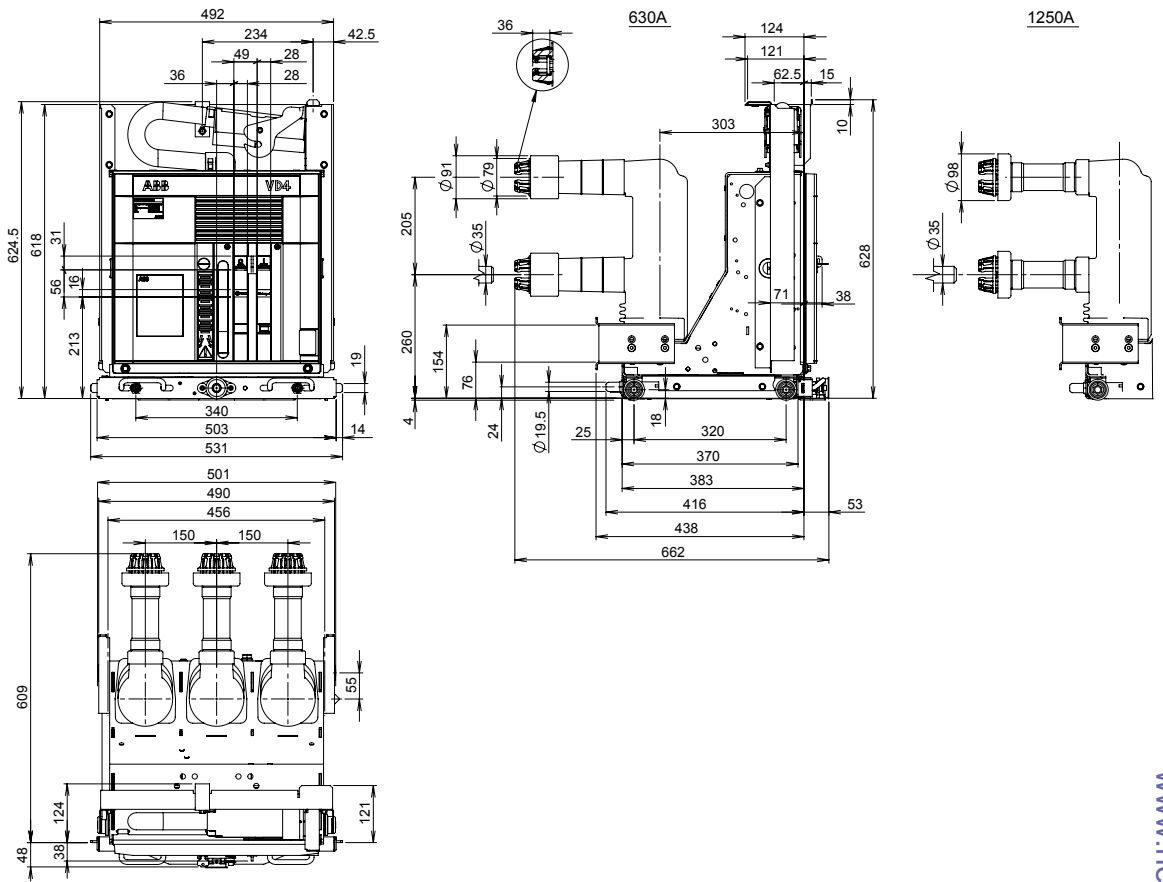

Withdrawable circuit-breakers for PowerCube modules

VD4/W	
TN	7420
Ur	12 kV
	17.5 kV
Ir	630 A
	1250 A
Isc	16 kA
	25 kA
	31.5 kA

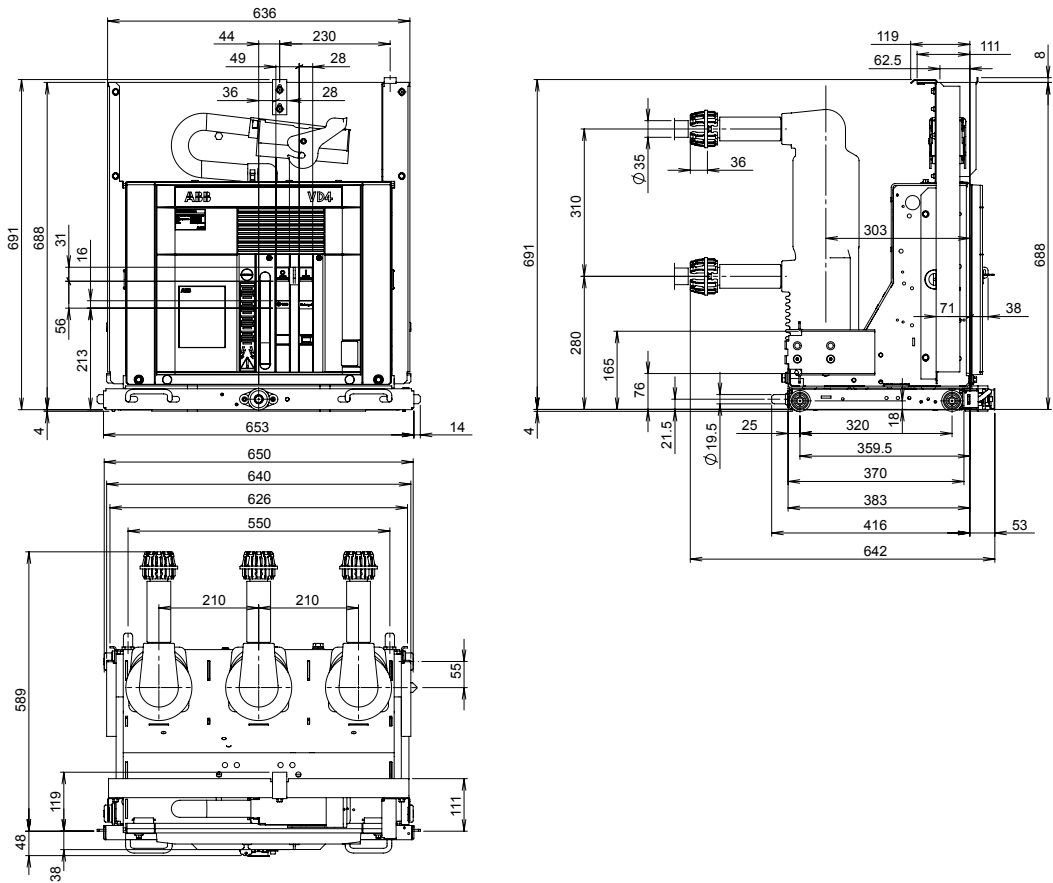

4. Overall dimensions

Withdrawable circuit-breakers for UniGear ZS1 switchgear and PowerCube modules

VD4/P	
TN	1VCD003284
Ur	12 kV
	17.5 kV
Ir	1250 A
	1600 A
Isc	40 kA

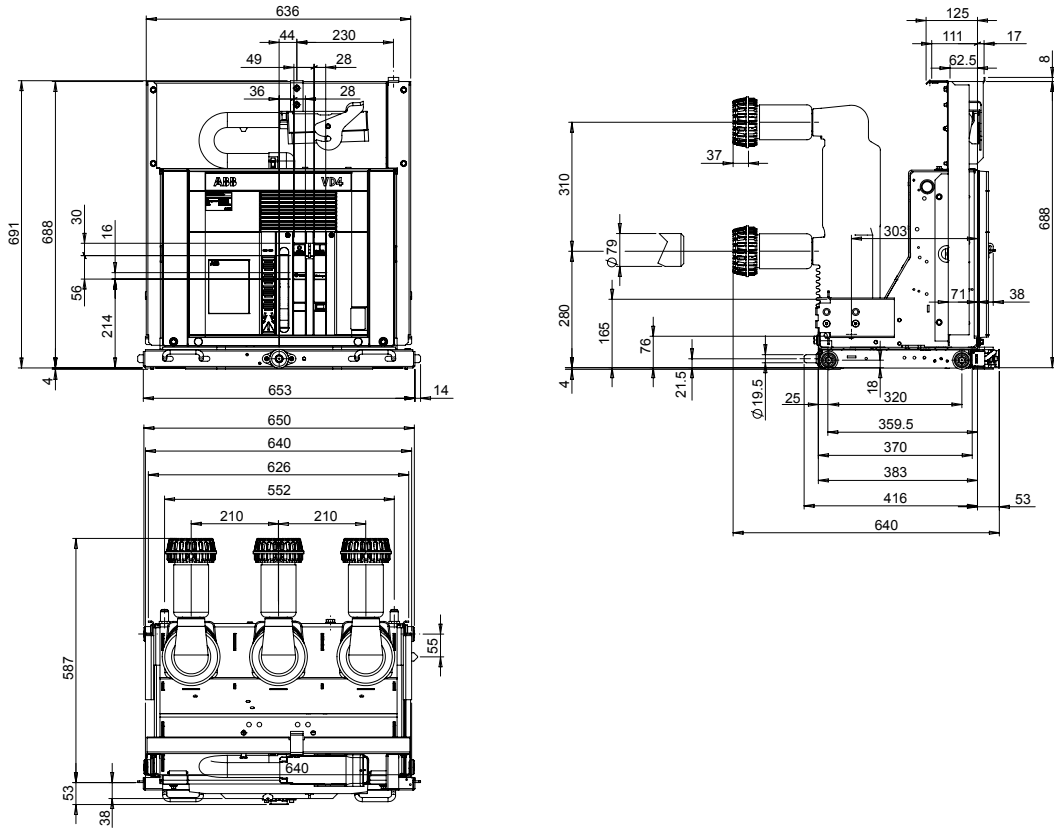

Withdrawable circuit-breakers for UniGear ZS1 switchgear and PowerCube modules

VD4/P	
TN	1VCD003286
Ur	12 kV
	17.5 kV
Ir	1250 A
	1600 A
Isc	40 kA

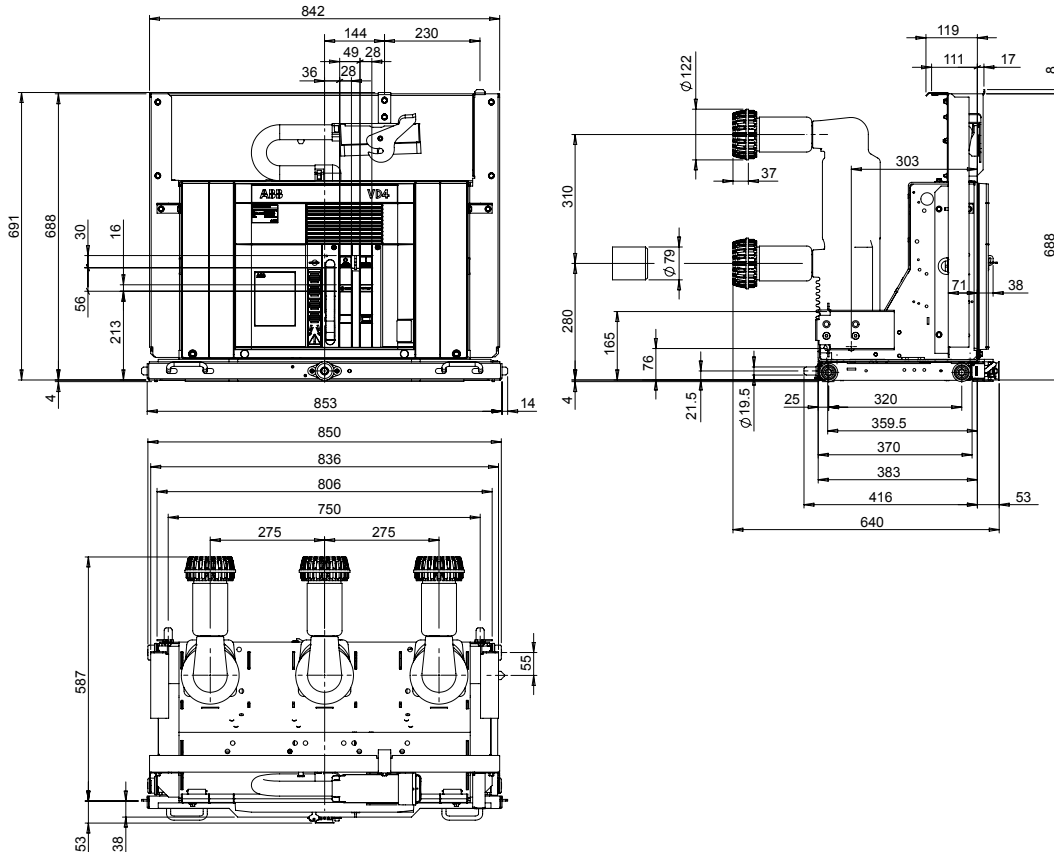

Withdrawable circuit-breakers for UniGear ZS1 switchgear and PowerCube modules

VD4/P	
TN	7415
Ur	12 kV
	17.5 kV
Ir	1600 A
	2000 A
Isc	20 kA
	25 kA
	31.5 kA

VD4/P	
TN	7415
Ur	12 kV
	17.5 kV
Ir	2000 A
Isc	40 kA

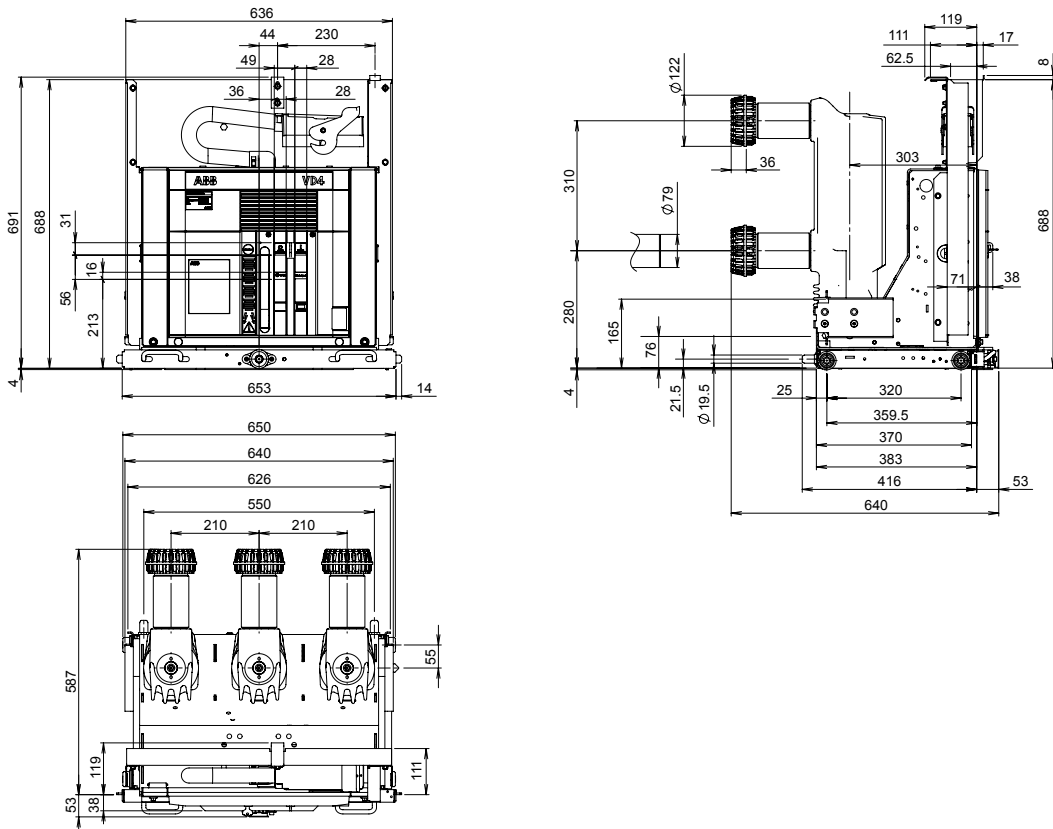

Withdrawable circuit-breakers for UniGear ZS1 switchgear and PowerCube modules

VD4/P	
TN	7416
Ur	12 kV
	17.5 kV
Ir	1600 A
	2000 A
Isc	20 kA
	25 kA
	31.5 kA

VD4/P	
TN	7416
Ur	12 kV
	17.5 kV
Ir	2000 A
Isc	40 kA

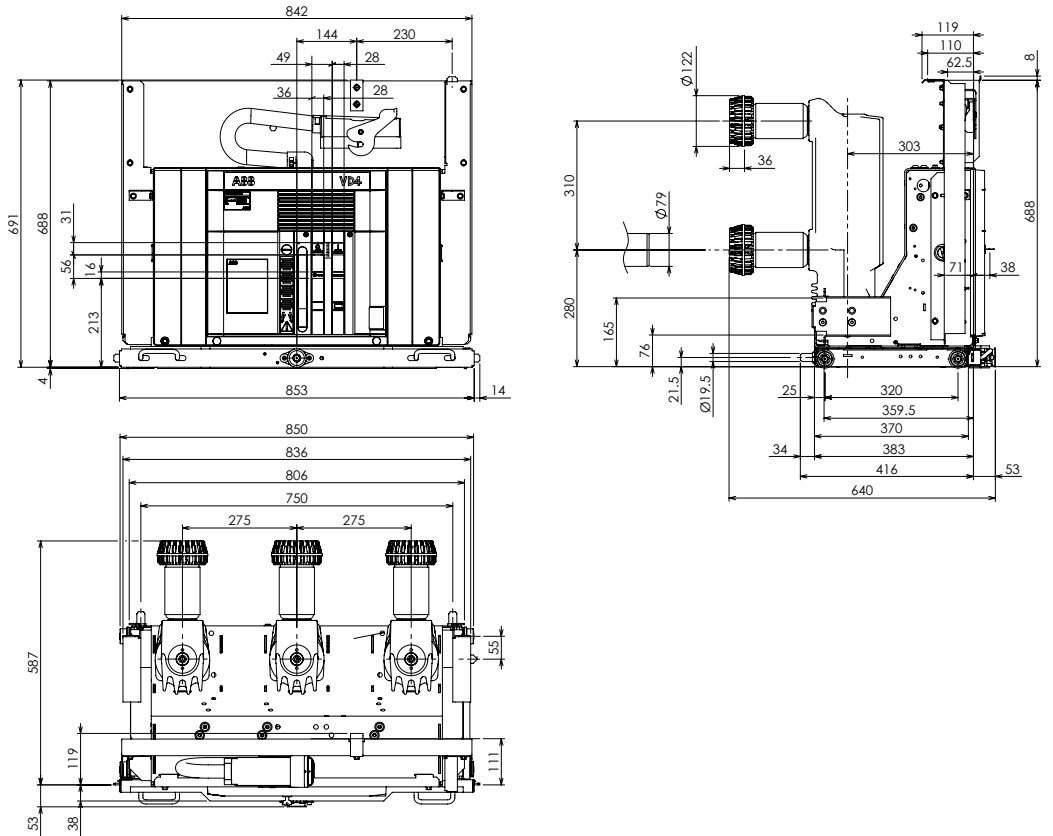

4. Overall dimensions

Withdrawable circuit-breakers for UniGear ZS1 switchgear and PowerCube modules

VD4/P	
TN	7417
Ur	12 kV
	17.5 kV
Ir	2500 A
	20 kA
Isc	25 kA
	31.5 kA
	40 kA

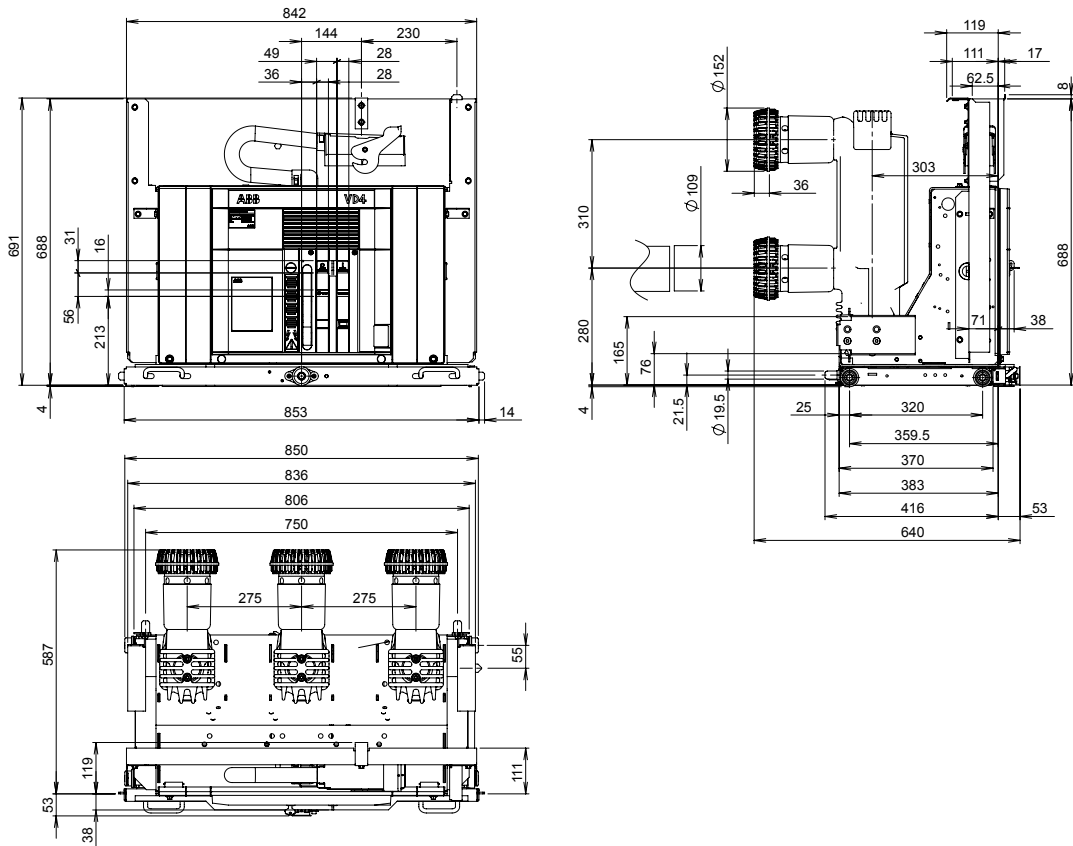

Withdrawable circuit-breakers for UniGear ZS1 switchgear and PowerCube modules

VD4/P	
TN	1VCD003444
Ur	12 kV
	17.5 kV
Ir	1250 A
	1600 A
Isc	2000 A
	50 kA

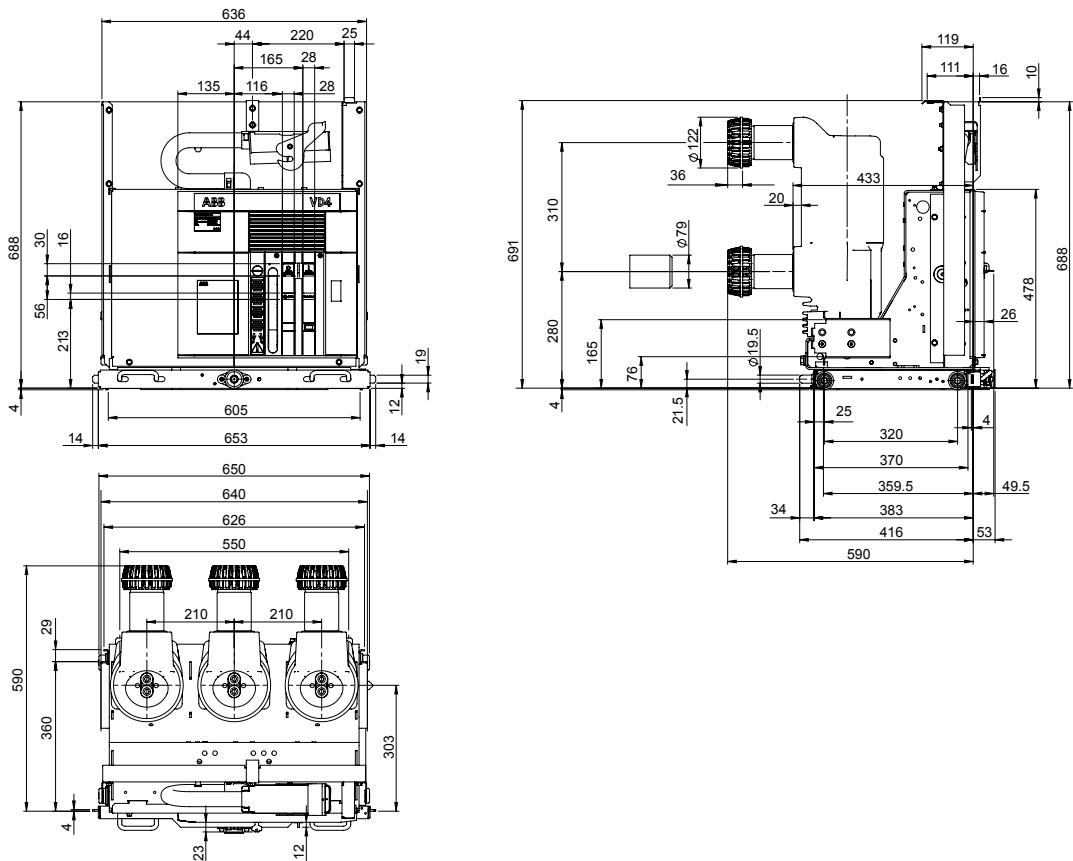

Withdrawable circuit-breakers for UniGear ZS1 switchgear

VD4/P	
TN	1VCD000153
Ur	12 kV
Ur	17.5 kV
Ir	3150 A (*)
Isc	20 kA
	25 kA
	31.5 kA
	40 kA

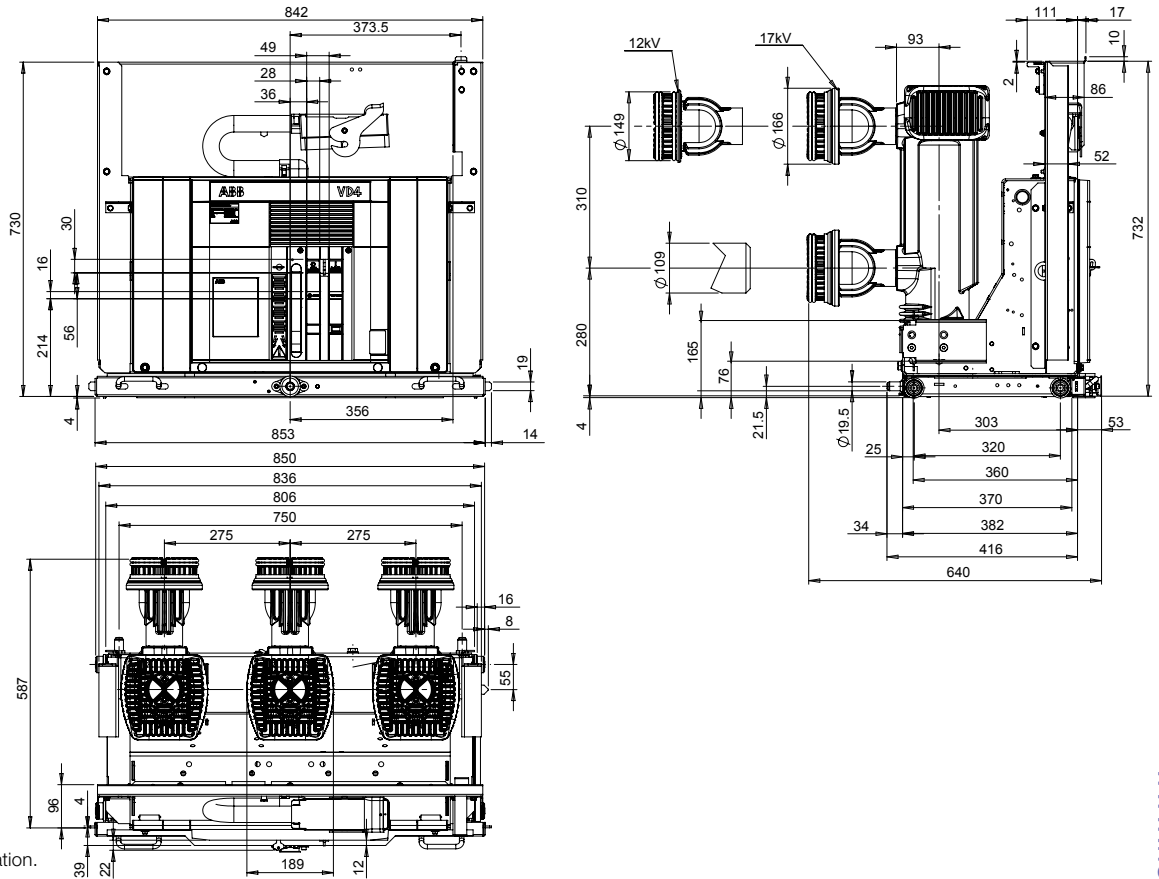

(*) 4000 A with forced ventilation.

Withdrawable circuit-breakers for UniGear ZS1 switchgear and PowerCube modules

VD4/P	
TN	7413
Ur	24 kV
Ir	630 A
Ir	1250 A
Isc	16 kA
	20 kA
	25 kA

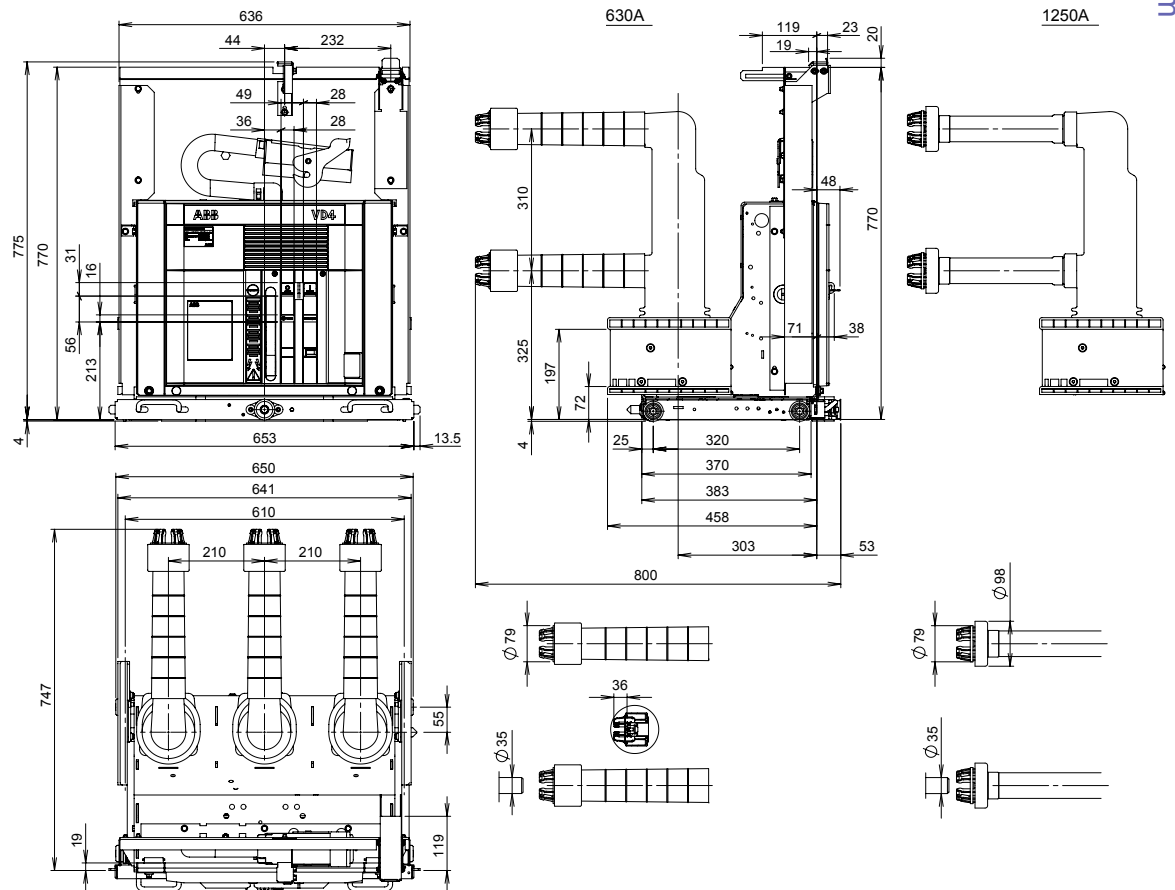

4. Overall dimensions

Withdrawable circuit-breakers for UniGear ZS1 switchgear

VD4/P	
TN	7414
Ur	24 kV
Ir	630 A
	1250 A
Isc	16 kA
	20 kA
	25 kA

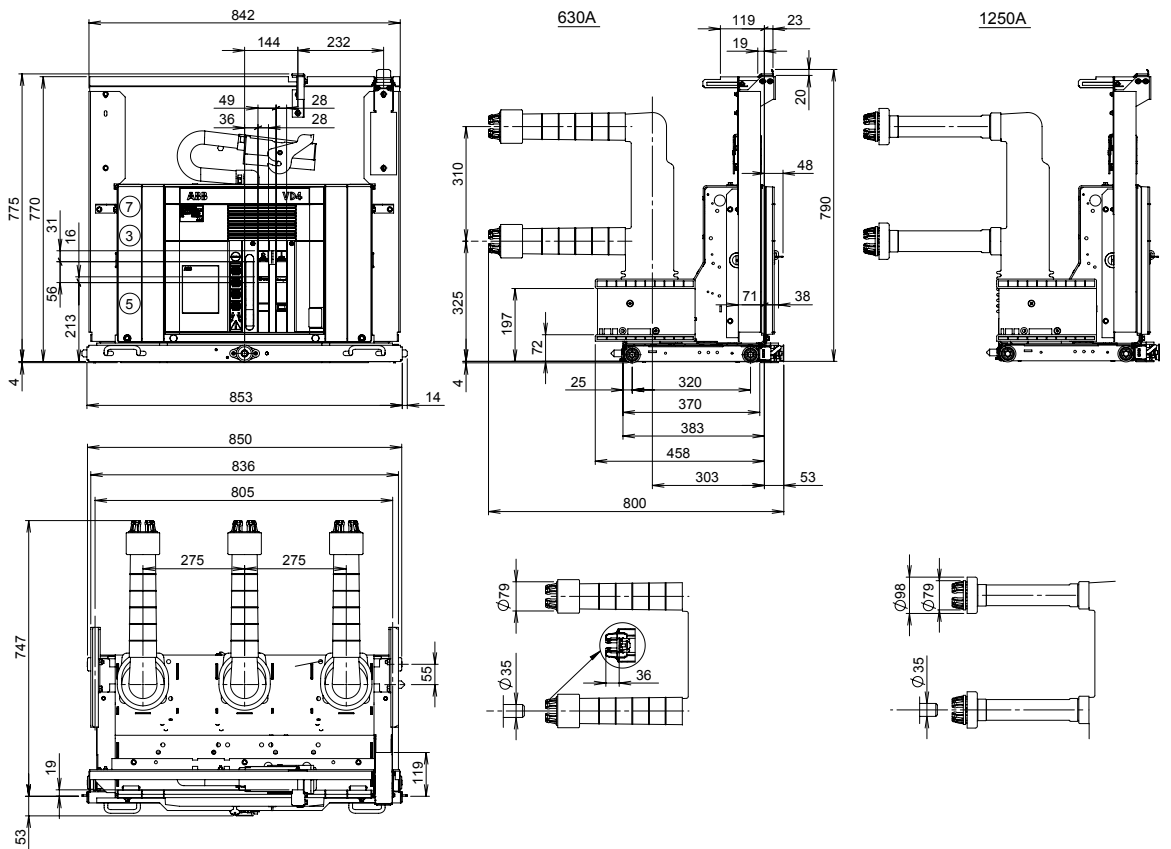

Withdrawable circuit-breakers for UniGear ZS1 switchgear

VD4/P	
TN	7418
Ur	24 kV
Ir	1600 A
	2000 A
	2500 A ⁽¹⁾
Isc	16 kA
	20 kA
	25 kA
	31.5 kA

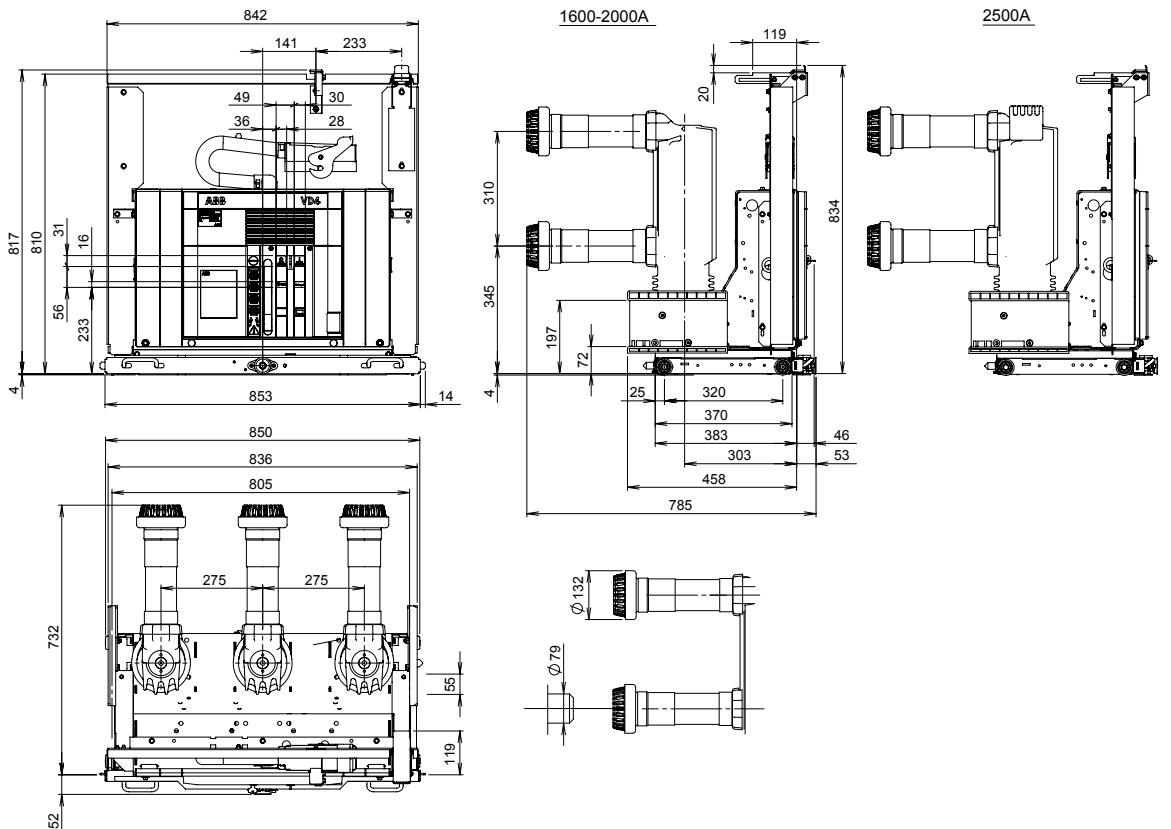

(1) The rated uninterrupted current of 2300 A is guaranteed with natural ventilation. The rated uninterrupted current of 2500 A is guaranteed with forced ventilation.

Withdrawable circuit-breakers for UniGear ZS1 switchgear

VD4/P	
TN	1VCD000173
Ur	24 kV
Ir	1250 A
Isc	31.5 kA

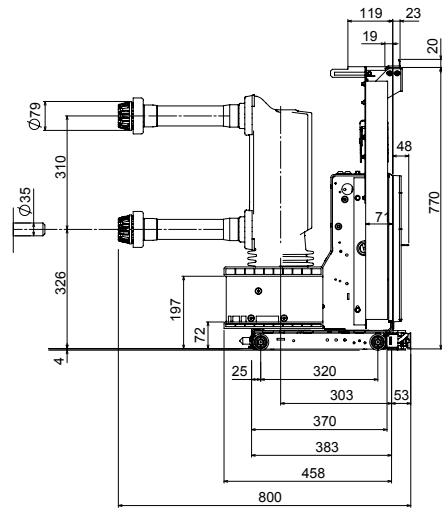
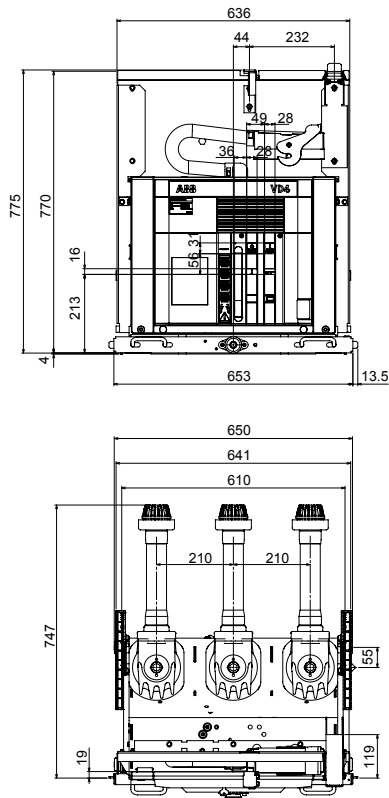

Withdrawable circuit-breakers for UniGear ZS1 switchgear

VD4/P	
TN	1VCD000177
Ur	24 kV
Ir	2700 A
Isc	31.5 kA

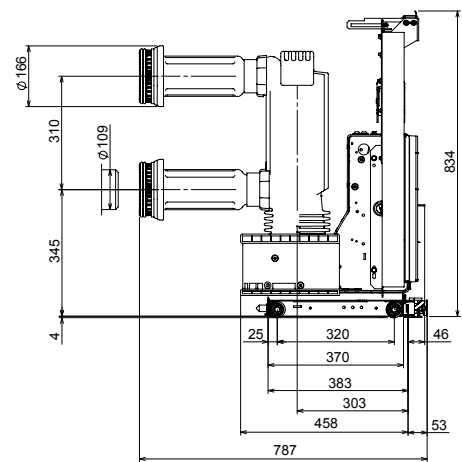
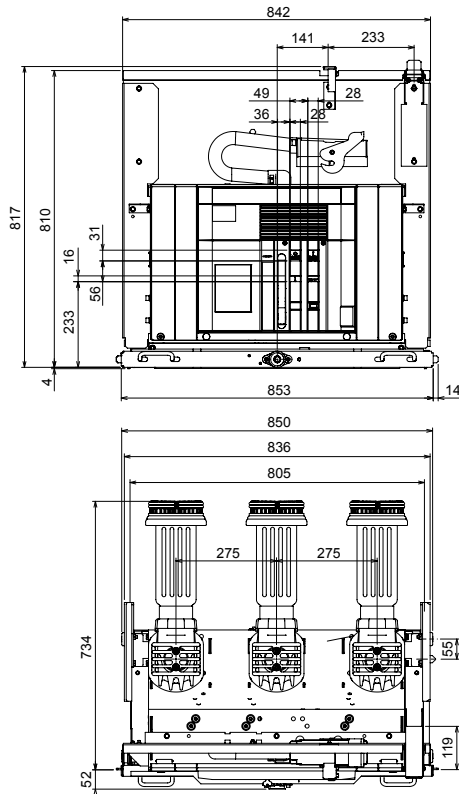

4. Overall dimensions

Withdrawable circuit-breakers for PowerCube modules

VD4/W	
TN	1VCD000152
Ur	12 kV
	17.5 kV
Ir	3150 A (*)
	20 kA
Isc	25 kA
	31.5 kA
	40 kA

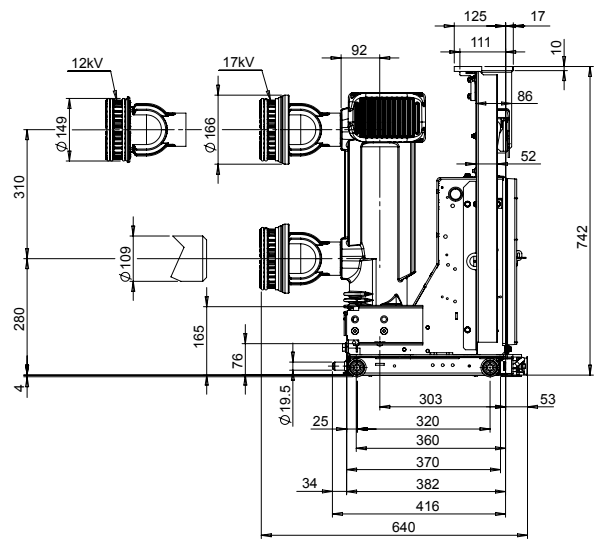
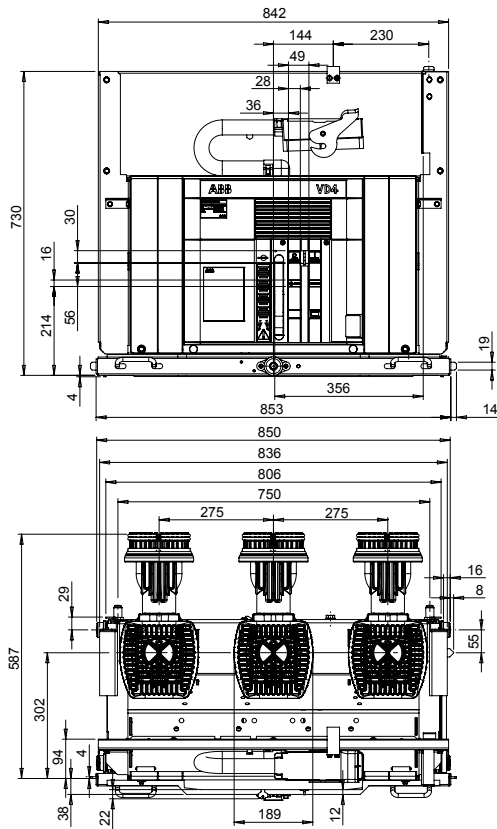

(*) 4000 A with forced ventilation.

Withdrawable circuit-breakers for ZS8.4 switchgear

VD4/Z8	
TN	1VCD000092
Ur	12 kV
Ir	630 A
Isc	20 kA
	25 kA

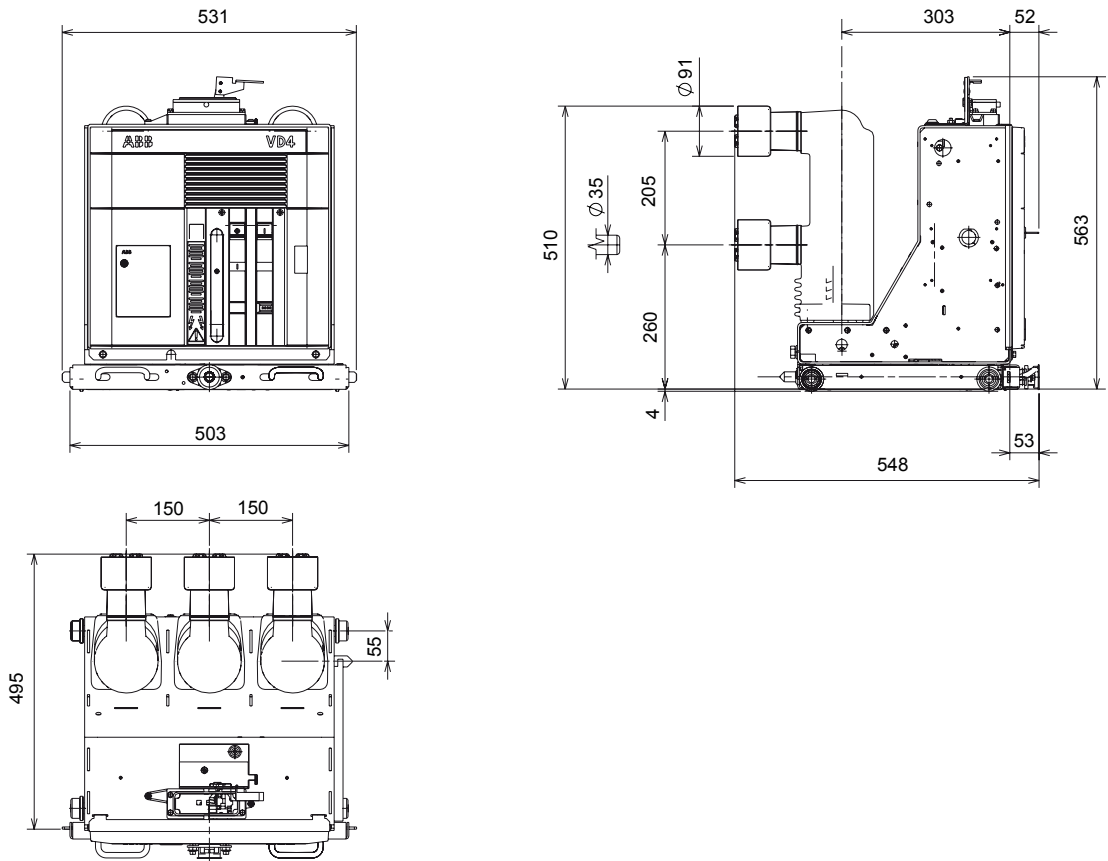

Withdrawable circuit-breakers for ZS8.4 switchgear

VD4/ZT8	
TN	1VCD000093
Ur	12 kV
Ir	630 A
Isc	20 kA
	25 kA

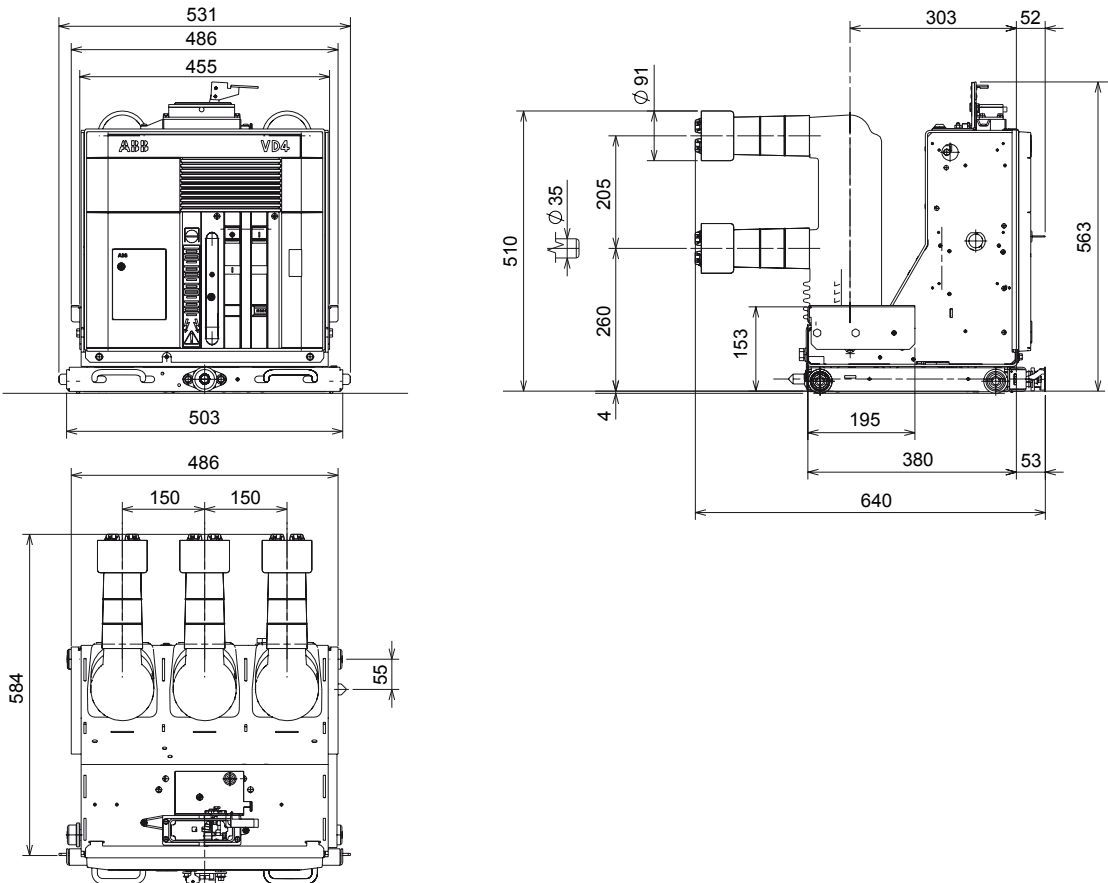

4. Overall dimensions

Withdrawable circuit-breakers for ZS8.4 switchgear

VD4/ZS8

TN	1VCD000091
Ur	12 kV
Ir	630 A
Isc	20 kA
	25 kA

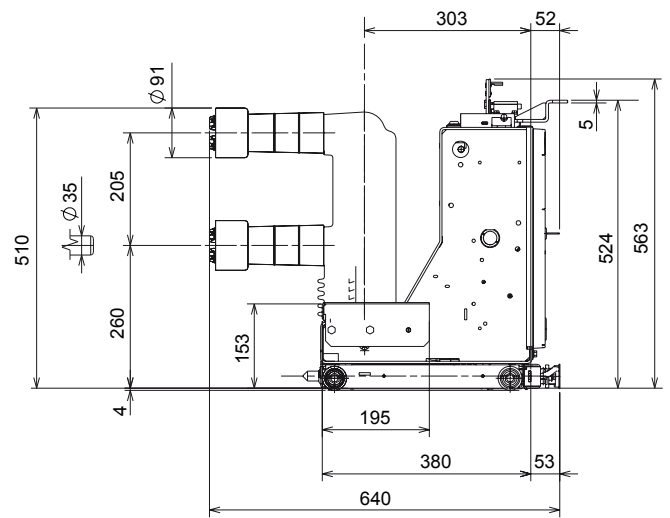
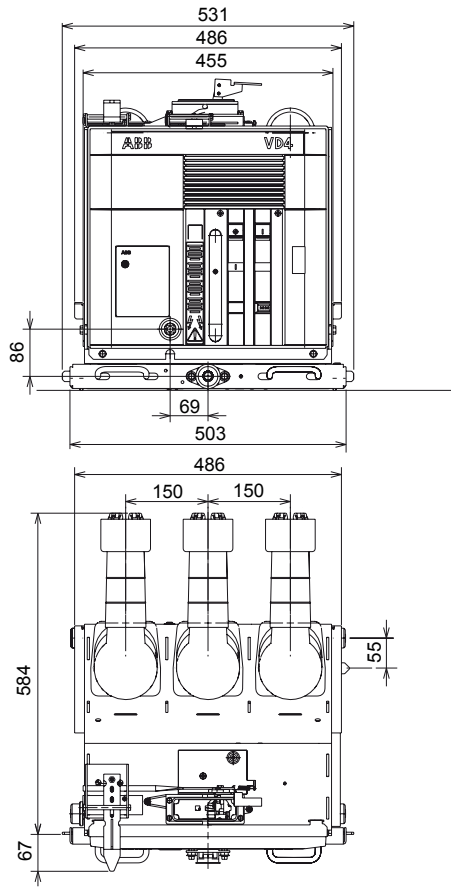

Withdrawable circuit-breakers for ZS8.4 switchgear

VD4/ZS8

TN	1VCD000133
Ur	12 kV
Ir	1250 A
Isc	20 kA
	25 kA

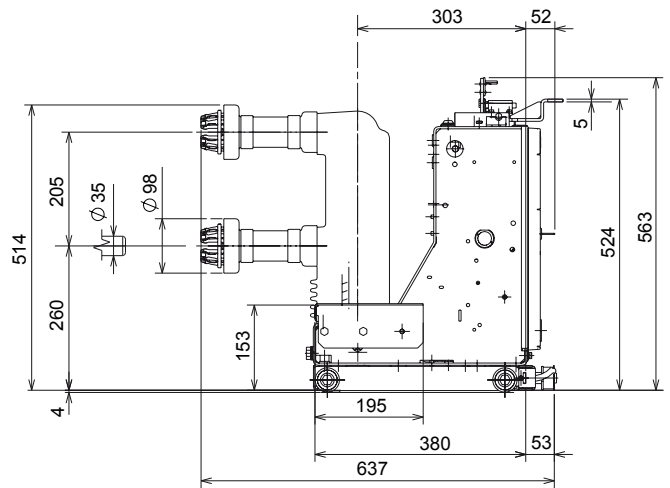
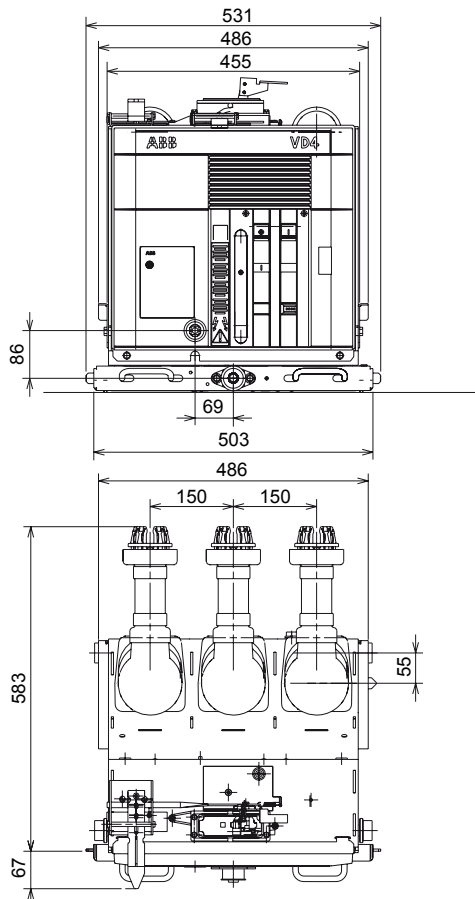

Withdrawable circuit-breakers for ZS8.4 switchgear

VD4/Z8	
TN	1VCD000137
Ur	12 kV
	17.5 kV
I_r	630 A
	1250 A
I_{sc}	20 kA
	25 kA

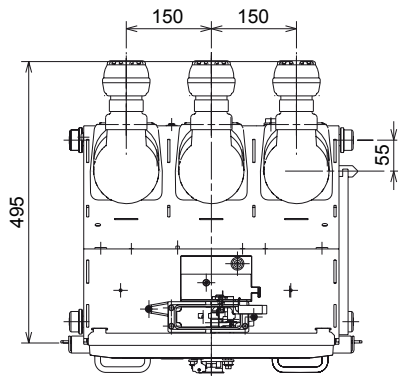
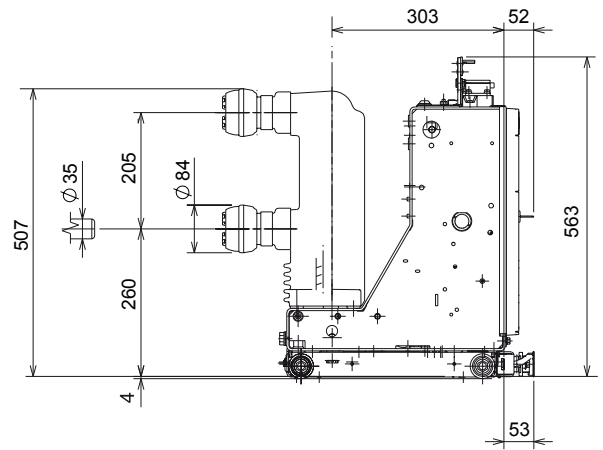
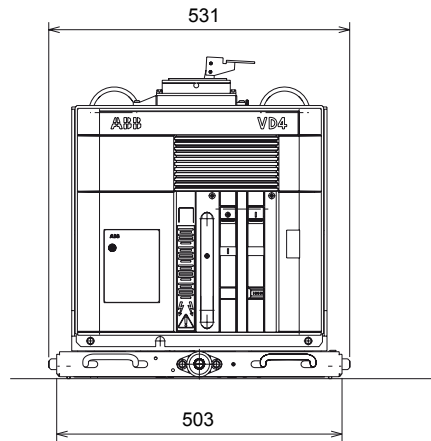

Withdrawable circuit-breakers for ZS8.4 switchgear

VD4/ZT8	
TN	1VCD000134
Ur	12 kV
	17.5 kV
I_r	630 A
	1250 A
I_{sc}	20 kA
	25 kA

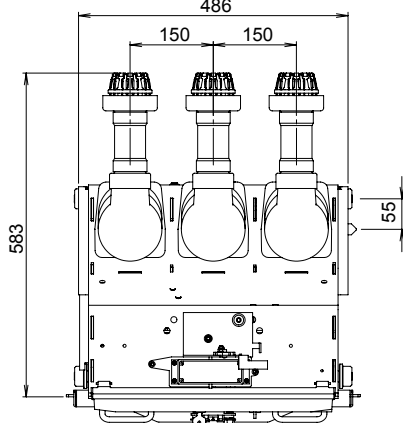
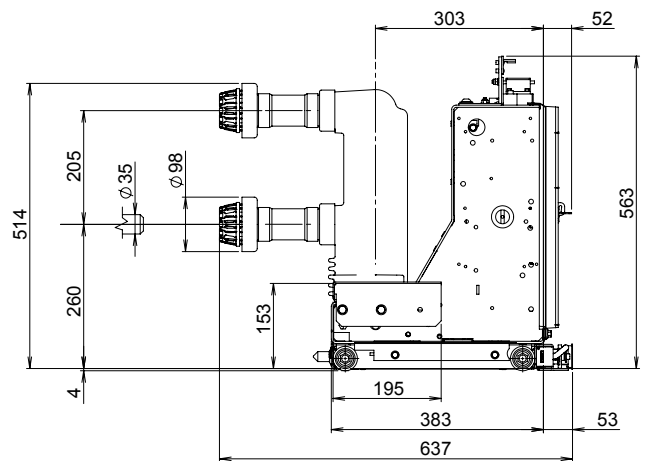
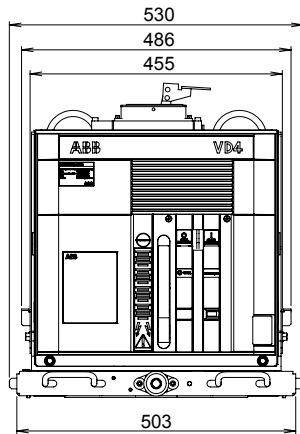

4. Overall dimensions

Withdrawable circuit-breakers for ZS8.4 switchgear

VD4/ZS8

TN	1VCD000088
Ur	24 kV
Ir	630 A
	16 kA
Isc	20 kA
	25 kA

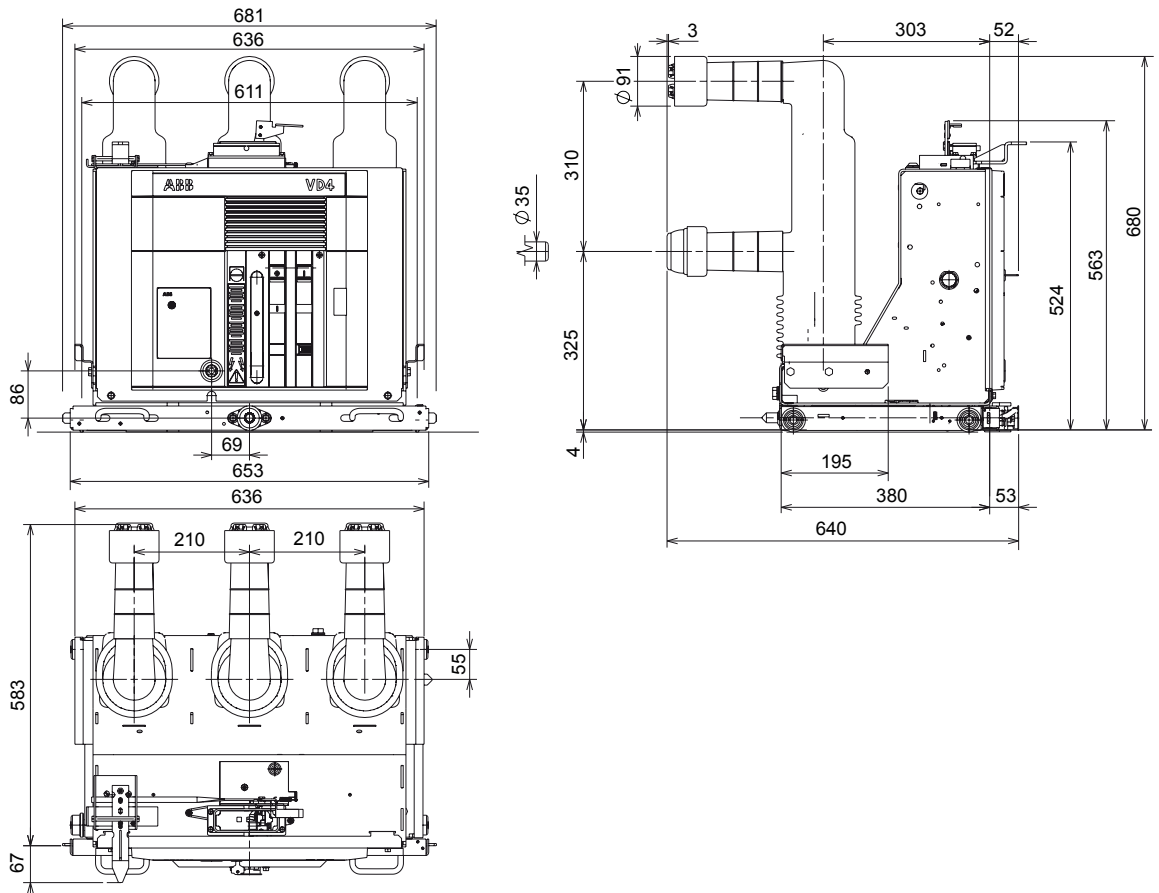

Withdrawable circuit-breakers for ZS8.4 switchgear

VD4/Z8

TN	1VCD000089
Ur	24 kV
Ir	630 A
	16 kA
Isc	20 kA
	25 kA

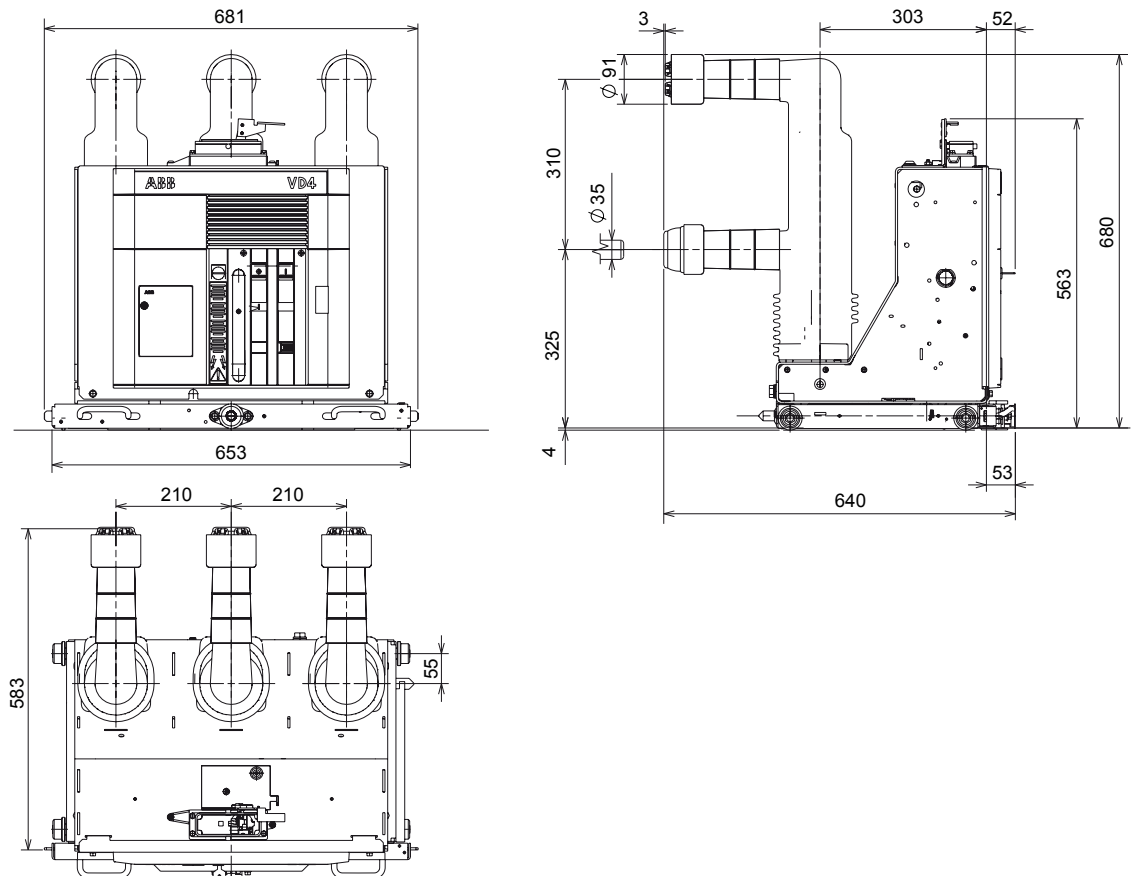

Withdrawable circuit-breakers for ZS8.4 switchgear

VD4/Z8	
TN	1VCD000138
Ur	24 kV
Ir	1250 A
	16 kA
Isc	20 kA
	25 kA

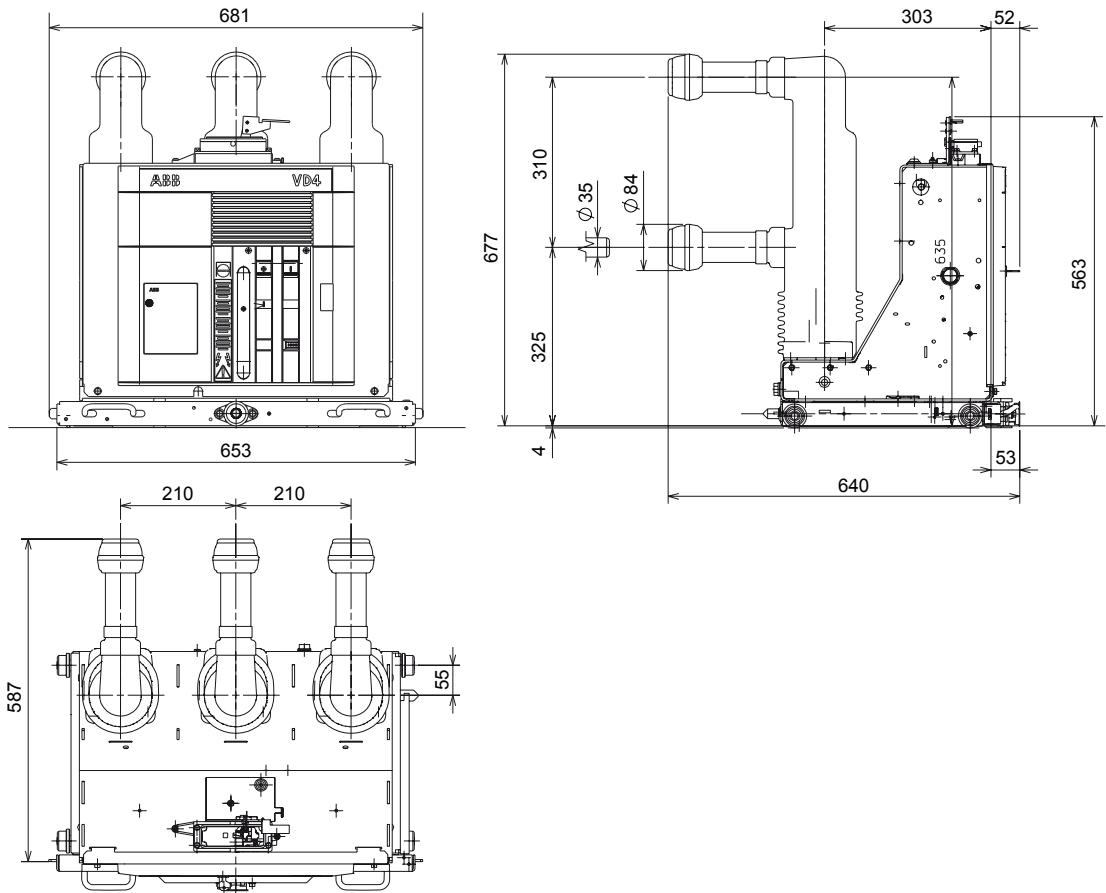

Withdrawable circuit-breakers for ZS8.4 switchgear

VD4/ZT8	
TN	1VCD000090
Ur	24 kV
Ir	630 A
	16 kA
Isc	20 kA
	25 kA

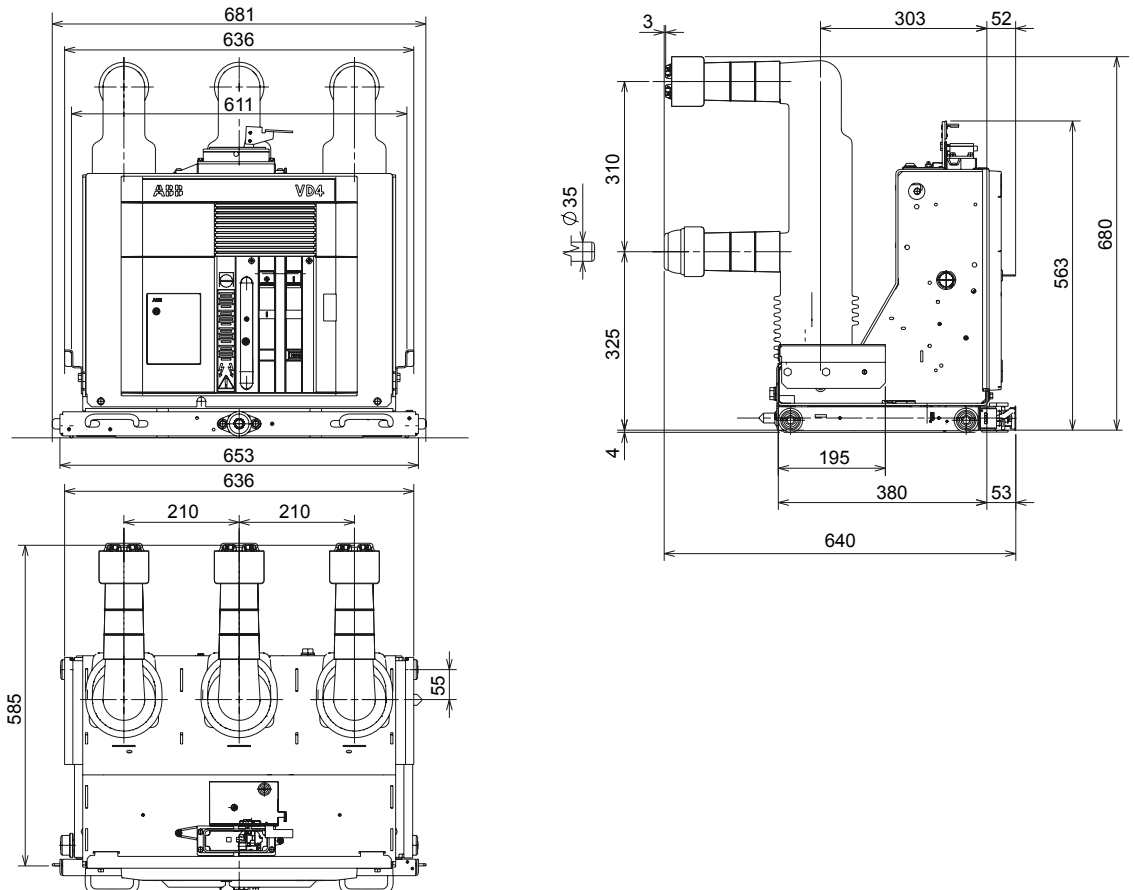

4. Overall dimensions

Withdrawable circuit-breakers for ZS8.4 switchgear

VD4/ZT8

TN	1VCD000136
Ur	24 kV
Ir	1250 A
	16 kA
Isc	20 kA
	25 kA

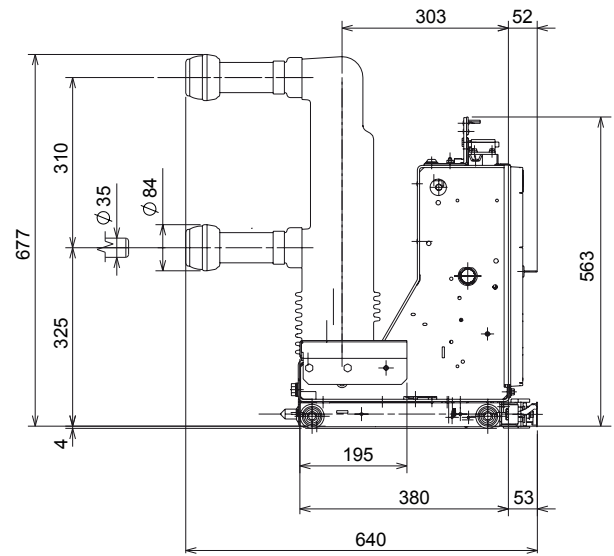
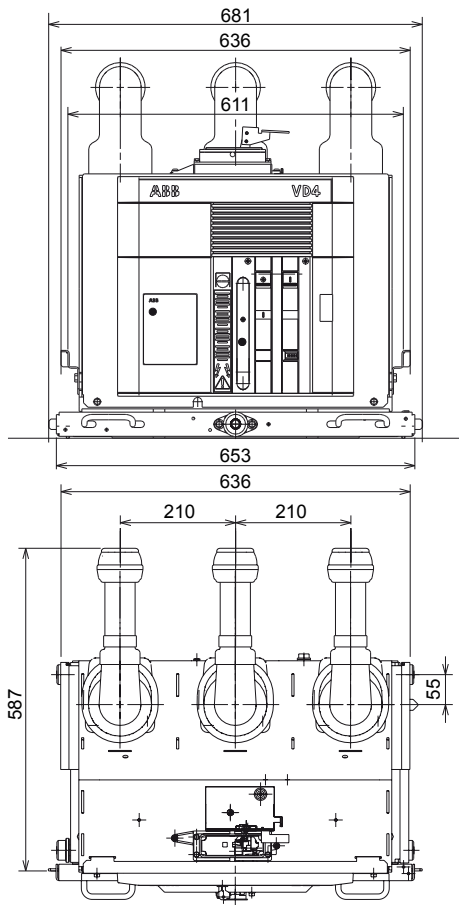

Withdrawable circuit-breakers for ZS8.4 switchgear

VD4/ZS8

TN	1VCD000135
Ur	24 kV
Ir	1250 A
	16 kA
Isc	20 kA
	25 kA

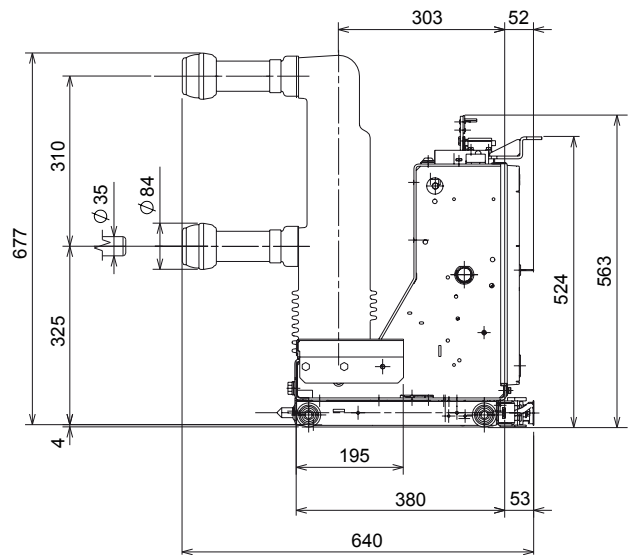
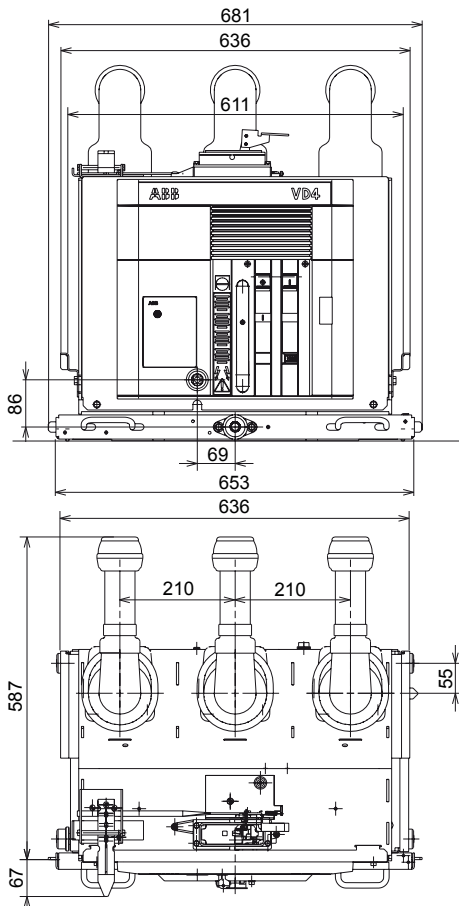

Withdrawable circuit-breakers for UniSwitch and UniMix switchgear

VD4/US	
TN	1VCD000047
Ur	24 kV
Ir	630 A
	1250 A
Isc	16 kA
	20 kA
	25 kA

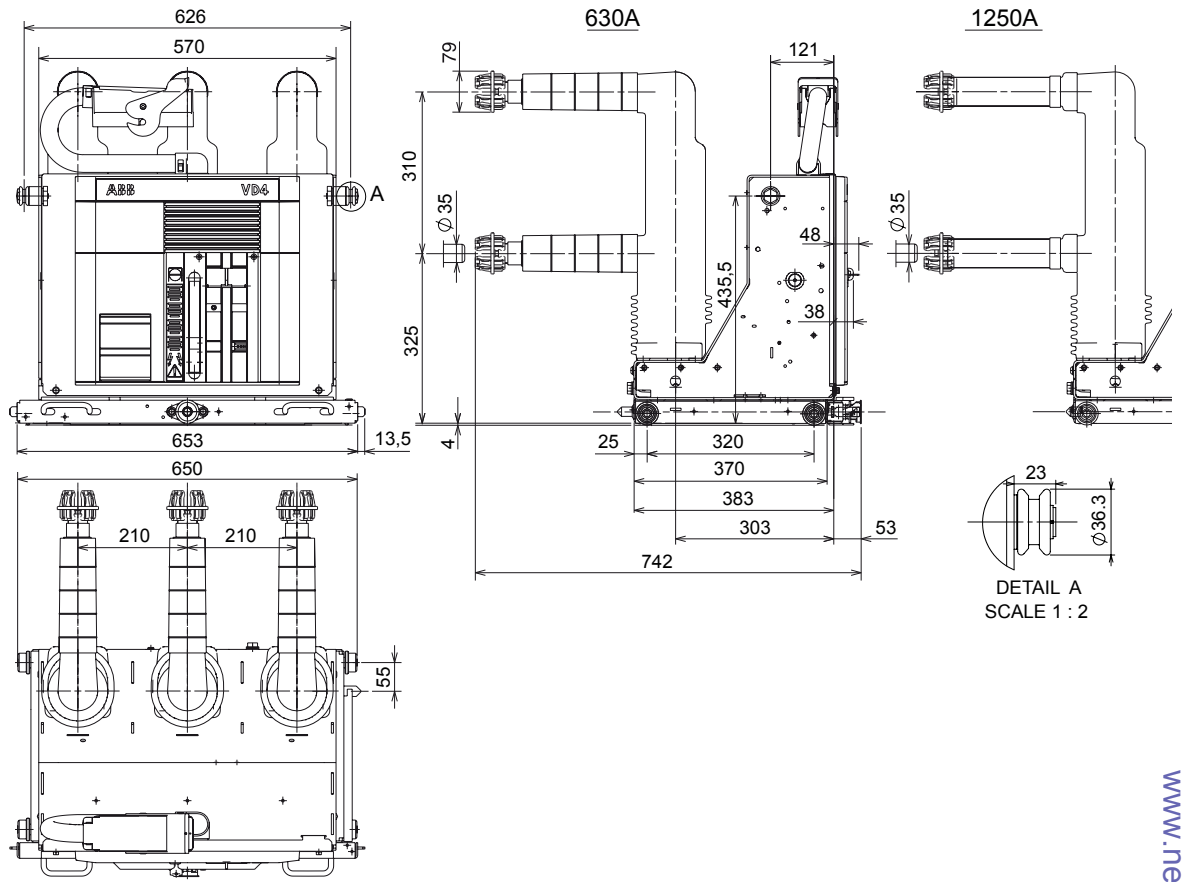

Withdrawable circuit-breakers for UniSec switchgear

VD4/SEC	
TN	1VCD000190
Ur	24 kV
Ir	630 A
	1250 A
Isc	16 kA
	20 kA
	25 kA

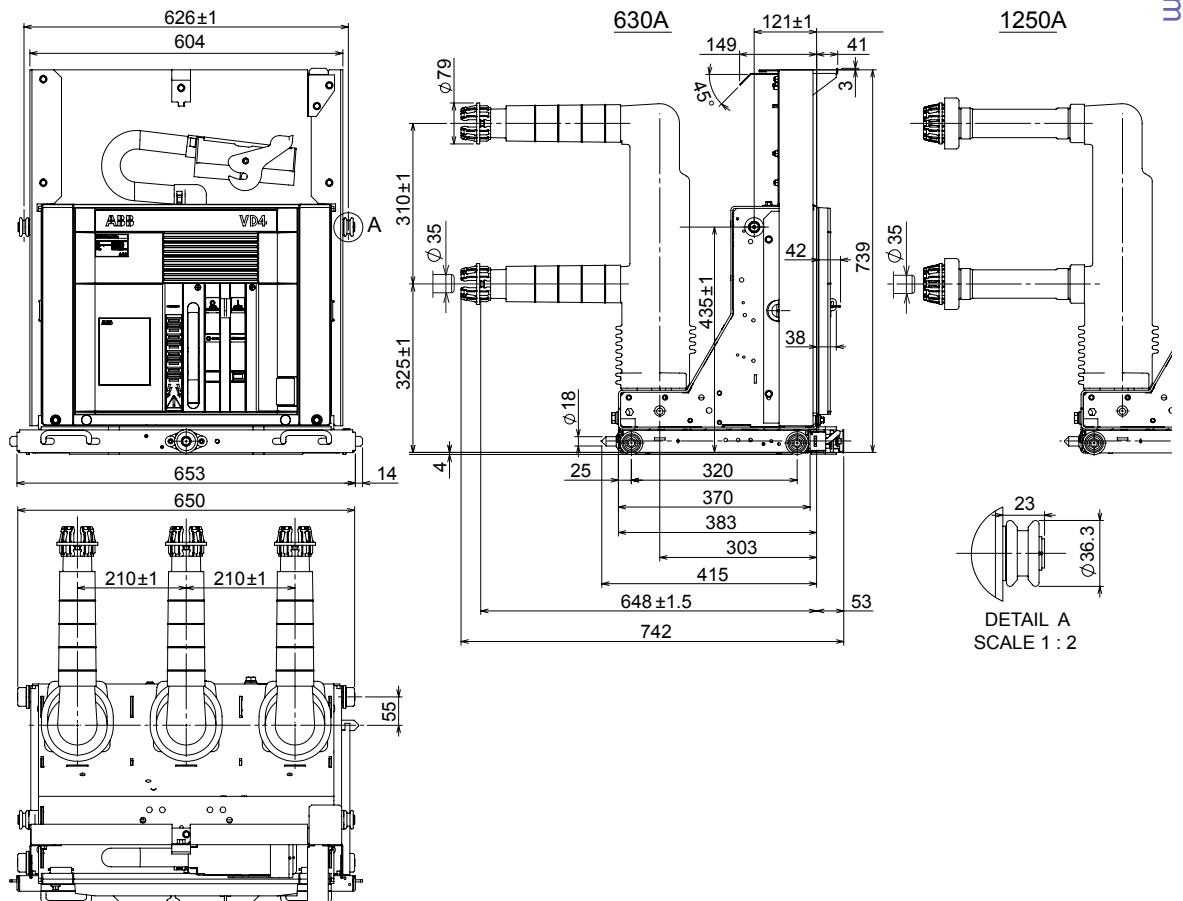

4. Overall dimensions

Withdrawable circuit-breakers for UniGear ZS2 switchgear and PowerCube modules (36 kV)

VD4	
TN	1VYN300901-KG
Ur	36 kV
I_r	1250 A
	1600 A
	2000 A
I_{sc}	31.5 kA

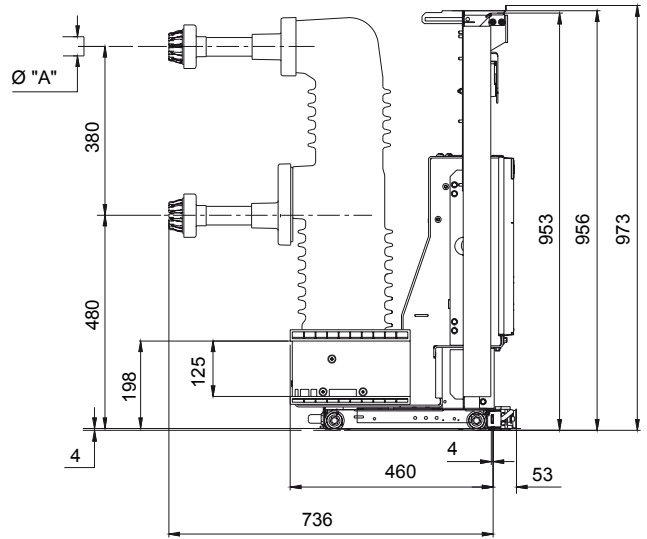
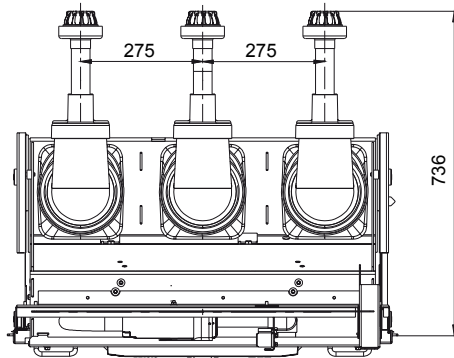
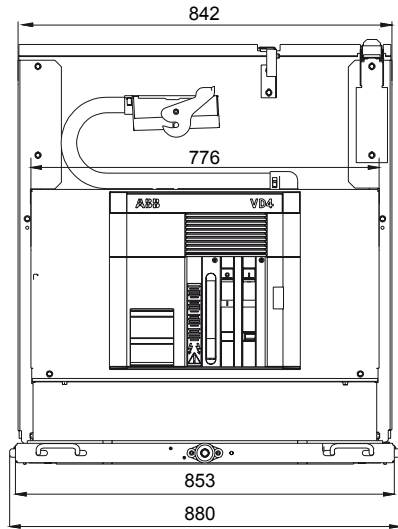

Breaker type	Ø A mm
VD4 36.12.32	35
VD4 36.16.32 - VD4 36.20.32	79

5. Electric circuit diagram

State of operation represented

The diagrams shows the following conditions:

- Circuit-breaker open and connected (only withdrawable circuit-breaker)
- Circuits de-energized
- Closing springs discharged

Graphical symbols for electric diagrams

	Thermal effect		Mass, frame		Capacitor (general symbol)		Passing make contact closing momentarily during release
	Electromagnetic effect		Conductors in shielded cable (two conductors shown)		Motor (general symbol)		Closing position contact (limit switch)
	Timing		Connection of conductors		Rectifier with two half-waves (bridge)		Opening position contact (limit switch)
	Pushbutton control		Terminal or clamp		Make contact		Power circuit-breaker with automatic opening
	Key control		Socket and plug (female and male)		Break contact		Control coil (general symbol)
	Earth (general symbol)		Resistor (general symbol)		Change-over break before make contact		Lamp (general symbol)

5. Electric circuit diagram

Electric circuit diagram of fixed circuit-breakers 1VCD 400046

The electric circuit diagram given in this section regards the fixed circuit-breakers with **breaking capacity up to 40 kA**.

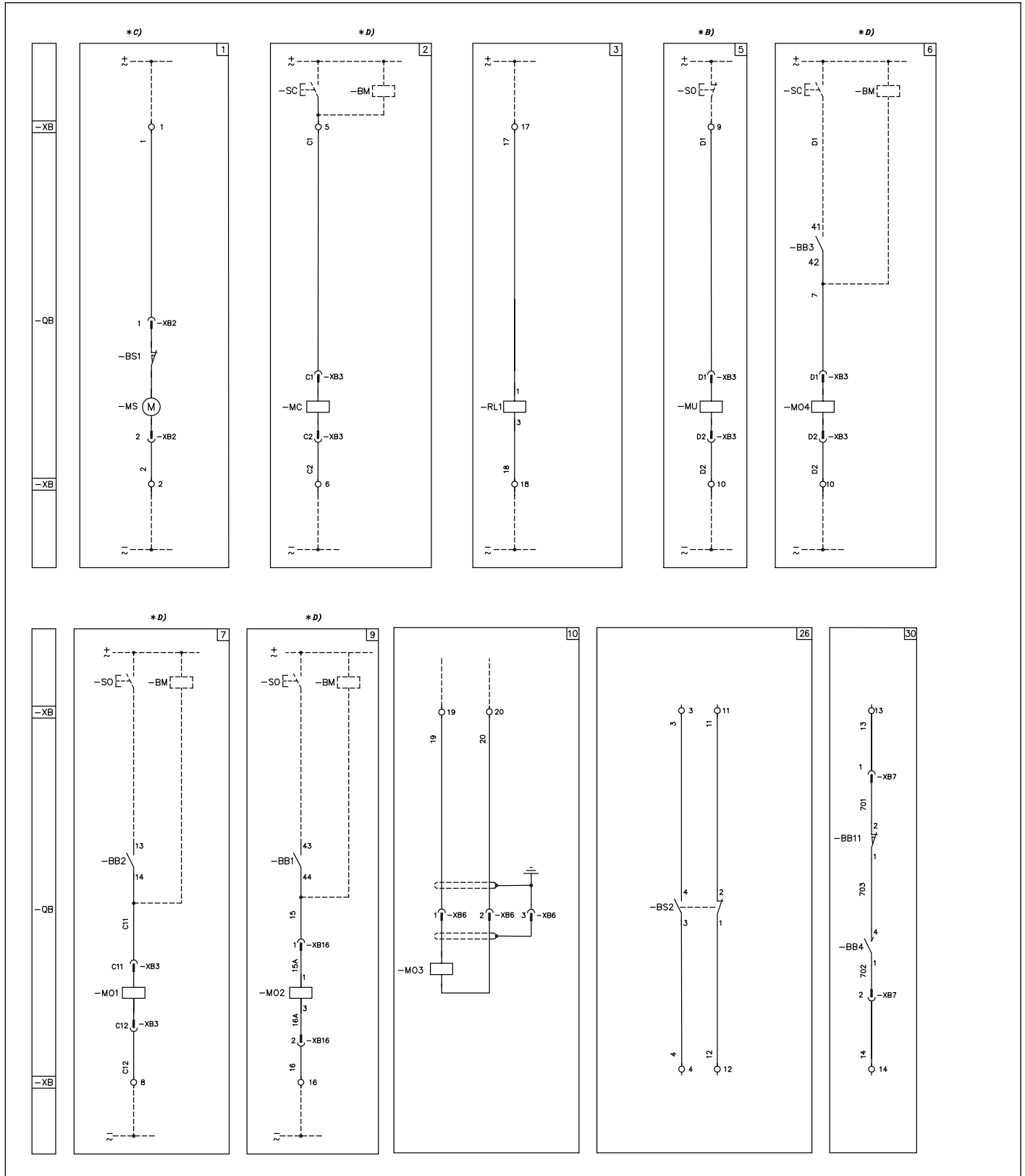

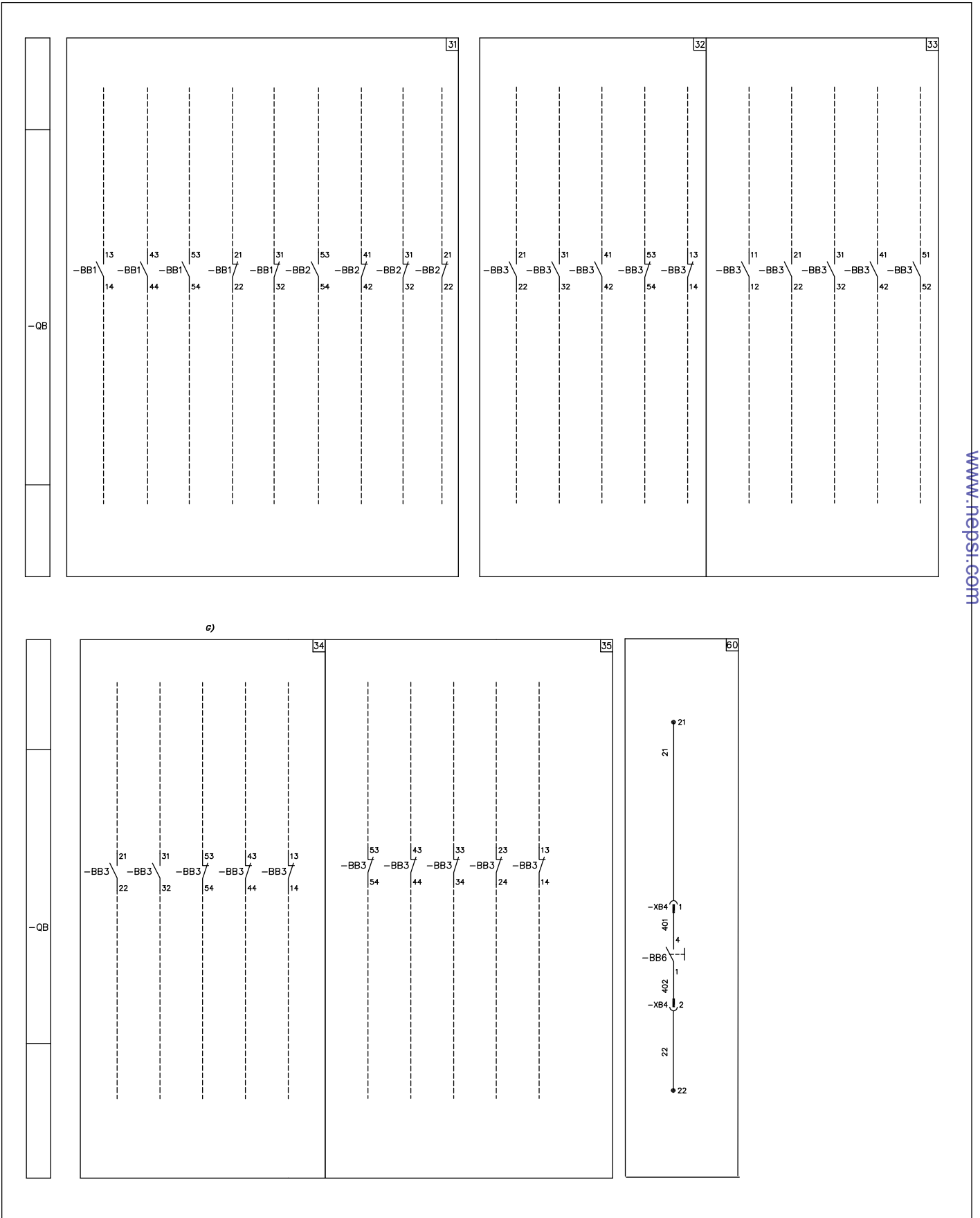

5. Electric circuit diagram

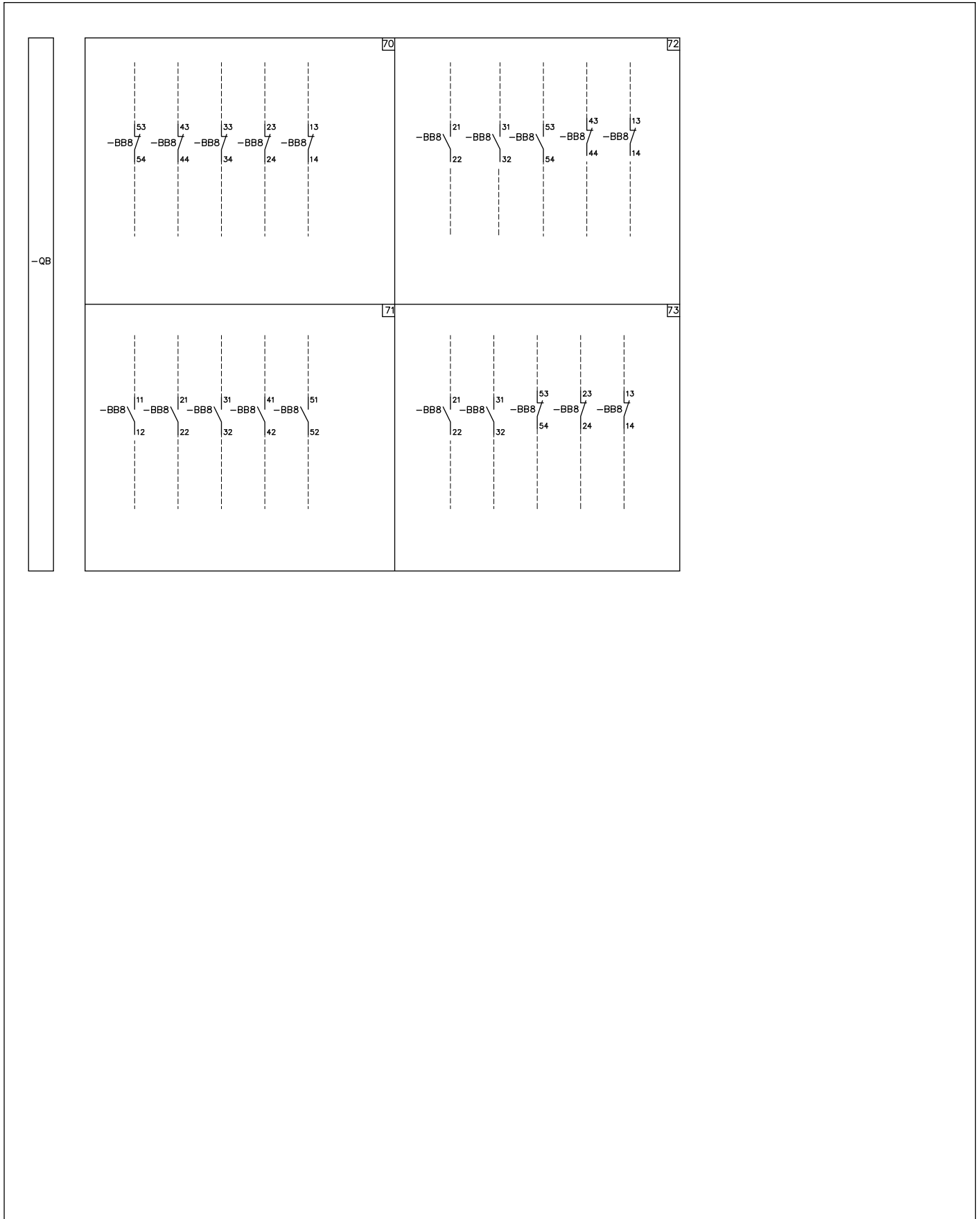

Caption

□	= Reference number of diagram figure.
*	= See the note indicated by the letter.
-BB1,...2-3	= Circuit-breaker auxiliary contacts.
-BB4	= Circuit-breaker auxiliary passing contact with momentary closing during opening.
-BB6	= Contact for the undervoltage release de-energized electrical signal
-BB11	= Contact to interrupt the –BB4 signal during the manual opening operation
-BM	= STU Test unit for supervision of shunt opening release and shunt closing release winding continuity (see note D).
-BS1	= Spring-charging motor limit contacts.
-BS2	= Limit contacts for signalling closing springs charged/discharged.
-MO1	= First shunt opening release (see note D).
-MO2	= Second shunt opening release (see note D).
-MO3	= Opening solenoid for release outside the circuit-breaker.
-MO4	= Third shunt opening release (see note D).
-MC	= Shunt closing release (see note D).
-MS	= Motor for closing spring charging (see note C).
-MU	= Undervoltage release (see note B).
-QB	= Circuit-breaker accessories.
-RL1	= Locking magnet. If de-energized, it mechanically prevents circuit-breaker closing (it is possible to limit its consumption by connecting a delayed pushbutton in series to enable the operation).
-SC	= Pushbutton or contact for circuit-breaker closing.
-SO	= Pushbutton or contact for circuit-breaker opening.
-XB	= Terminal box for the circuit-breaker circuits.
-XB2...16	= Accessory connectors.

Description of figures

Fig. 1	= Motor circuit for closing spring charging (see note C).
Fig. 2	= Shunt closing release (anti-pumping is carried out mechanically) (see note D).
Fig. 3	= Locking magnet. When de-energised, it mechanically prevents circuit-breaker closing. It is possible to limit consumption by connecting a delay pushbutton in series to enable the operation.
Fig. 5	= Instantaneous undervoltage release (see note B).
Fig. 6	= Circuit of third opening release with continuous control of the winding (see note D).
Fig. 7	= Circuit of the first shunt opening release with possibility of continuous control of the winding (see note D).
Fig. 9	= Circuit of the second shunt opening release with possibility of continuous control of the winding (see note D).
Fig. 10	= Opening solenoid for release outside the circuit-breaker.
Fig. 26	= Electrical signalling of closing springs charged and discharged.
Fig. 30	= Circuit-breaker auxiliary passing contact with momentary closing during circuit-breaker opening.
Fig. 31	= Available circuit-breaker auxiliary contacts.
Fig. 32 ÷ 35	= Available circuit-breaker auxiliary contacts. It is possible to have one of these figures. The standard configuration is figure 32.
Fig.60	= Contact for the undervoltage release de-energized electrical signal.
Fig. 70 to 73	= Available auxiliary contacts of the circuit-breaker. One of these figures can be obtained.

5. Electric circuit diagram

Selection of the figures

	Description	Figures	Notes
-MS	Spring charging motor	1	C
-MC	Shunt closing release	2	D
-MO1	Shunt opening release	7	D
-MU	Undervoltage release	5	B
-MO2	Additional shunt opening release	9	D
-BB1 -BB2	Set of 10 circuit-breaker auxiliary contacts	31	
	Set of 5 extra circuit-breaker auxiliary contacts 3C-20	32	
	Set of 5 extra circuit-breaker auxiliary contacts 5C	33	
	Set of 5 extra circuit-breaker auxiliary contacts 2C-30	34	
-BB3	Set of 5 extra circuit-breaker auxiliary contacts 50	35	
	Notes: C = normally open contact with circuit-breaker open 0 = normally closed contact with circuit-breaker open		
-RL1	Locking magnet on operating mechanism	3	
-BB4	Transient contact	30	
-BS2	Contact for signalling closing spring charged/discharged	26	
-MO3	Opening solenoid for release outside the circuit-breaker	10	F
-MO4	Third shunt opening release	6	D

Incompatibility

The combination of circuits given in the figures below are not possible on the same circuit-breaker:

32-33-34-35

Notes

- A) The circuit-breaker is only fitted with the accessories specified in the order acknowledgement. To draw up the order, please consult this catalogue.
- B) The undervoltage release can be supplied for power supply branched on the supply side of the circuit-breaker or from an independent source.
Circuit-breaker closing is only possible with the undervoltage release energized (the lock on closing is made mechanically). In the case where there is the same power supply for the shunt closing and undervoltage releases and automatic circuit-breaker closing is required on return of the auxiliary voltage, a delay of 50ms must be introduced between the moment of consent to the undervoltage release and energization of the shunt closing release.
Incompatible with -MO4.
- C) Check the auxiliary circuit power to verify the possibility of starting several motors for charging the closing springs at the same time.
To prevent excessive consumption the closing springs must be charged manually before energizing the auxiliary circuit.
- D) The circuit for controlling the shunt opening release winding continuity must only be used for this purpose.
It is possible to use the STU Test Unit to check continuity of the various release.
- E) When fig. 06 is required, contact -BB3 (41-42) of fig. 32-33 is not available and figs. 34-35 cannot be supplied. When fig. 09 is required, contact -BB1 (43-44) of fig. 31 is not available.

Electric circuit diagram of fixed circuit-breakers 1VCD 400099

The electric circuit diagram given in this section regards the fixed circuit-breakers **with breaking capacity up to 50 kA.**

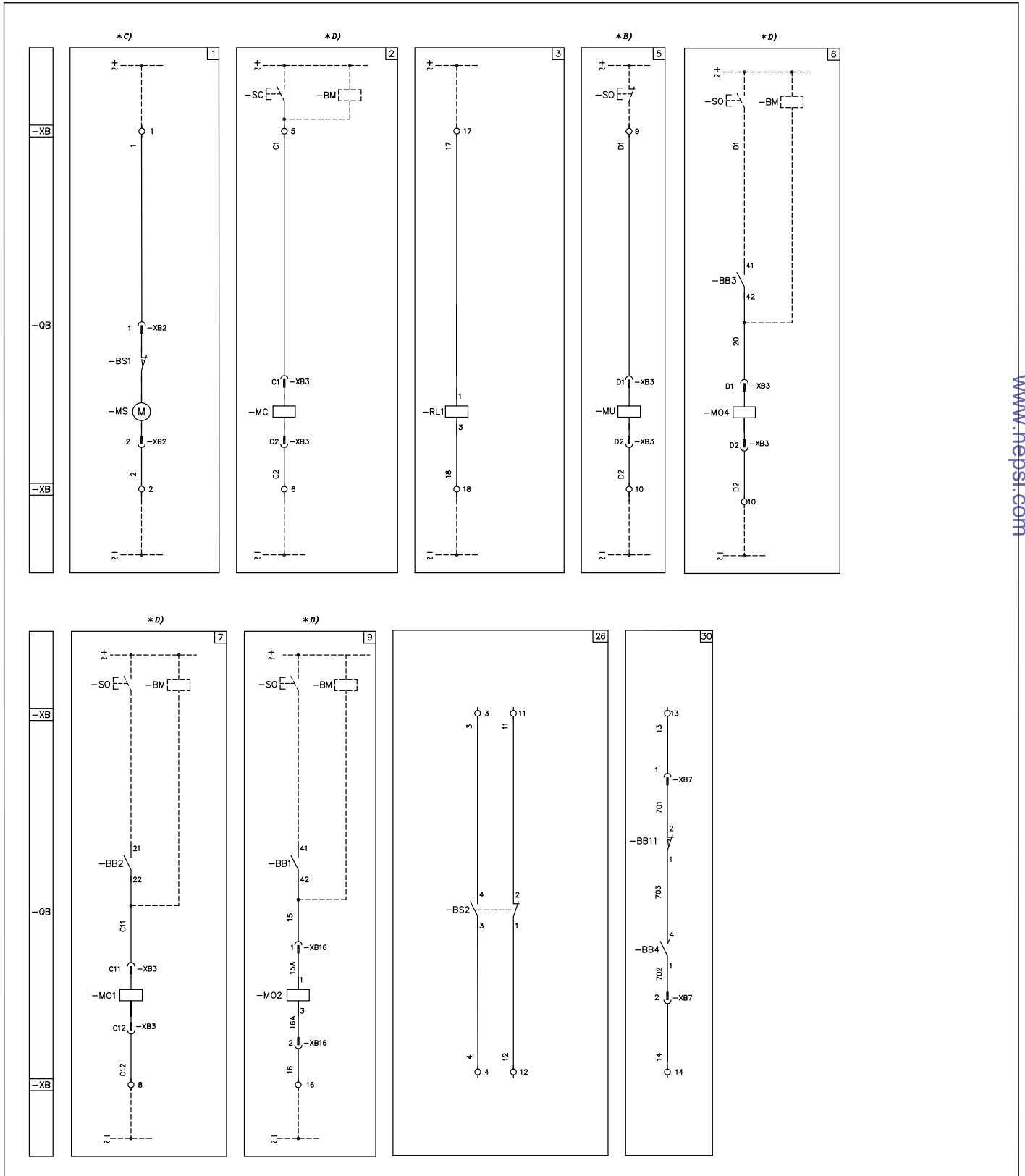

5. Electric circuit diagram

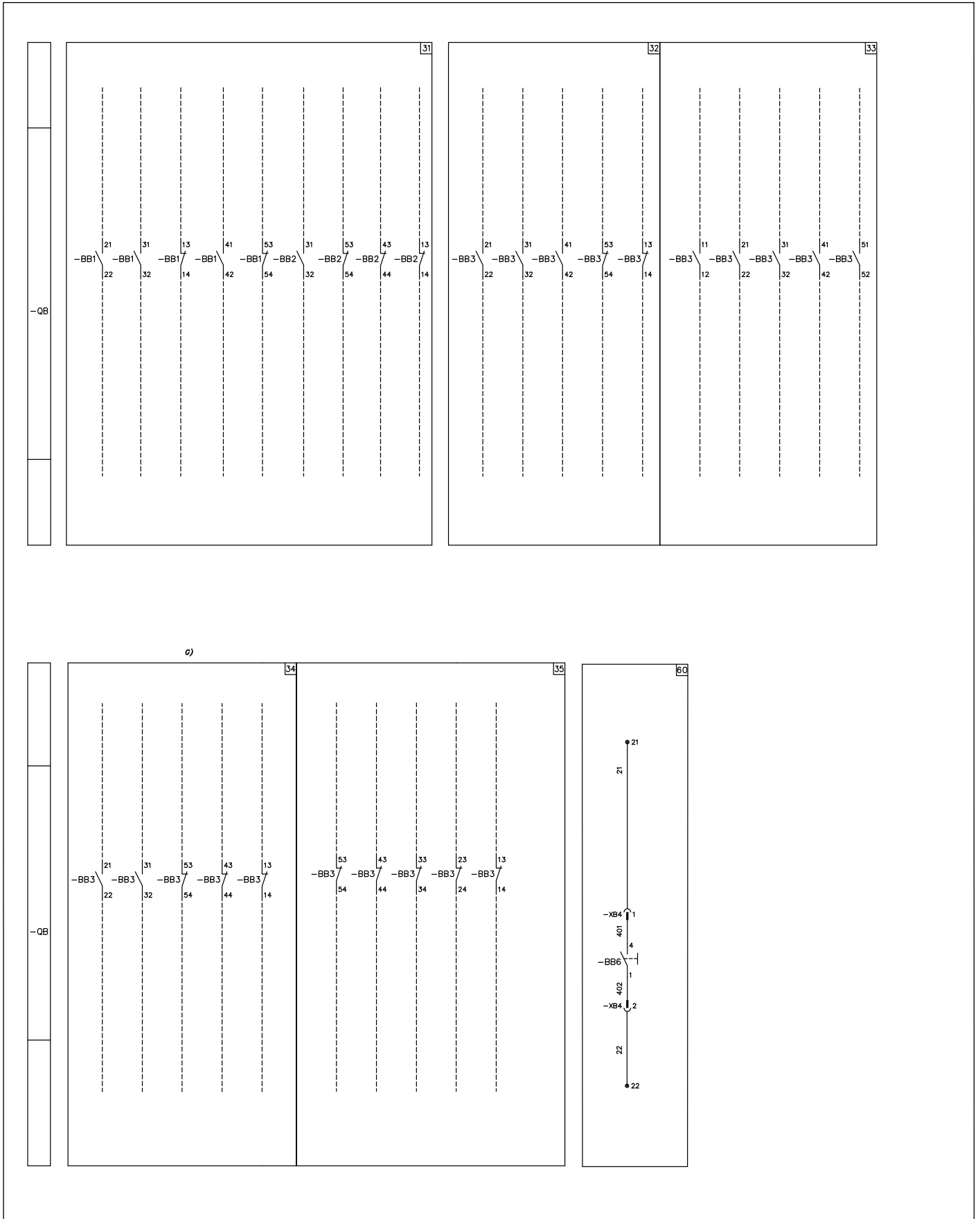

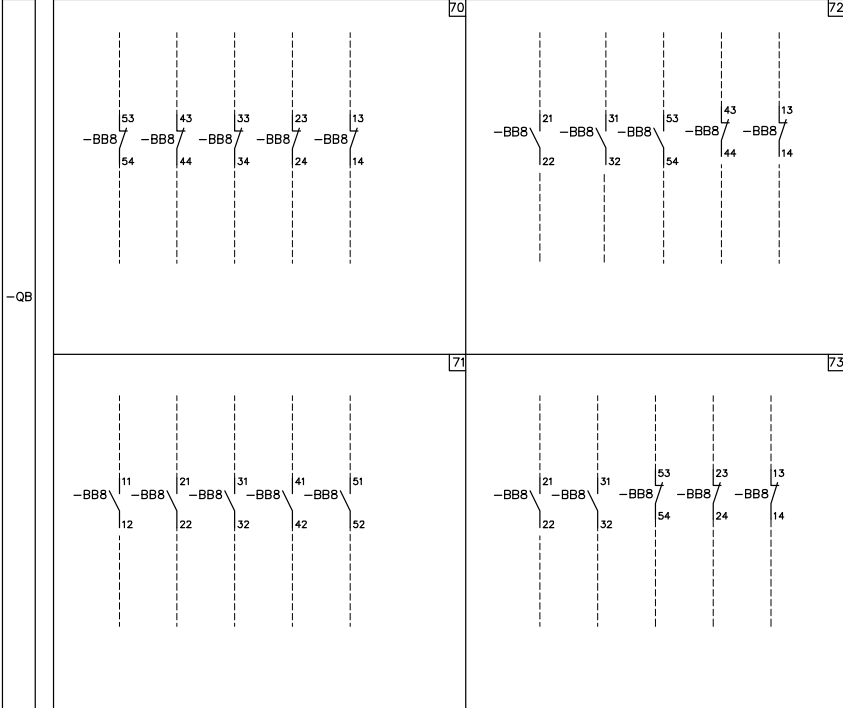

5. Electric circuit diagram

Caption

□	= Reference number of diagram figure.
*	= See the note indicated by the letter.
-BB1,...2-3	= Circuit-breaker auxiliary contacts.
-BB4	= Circuit-breaker auxiliary passing contact with momentary closing during opening.
-BB6	= Contact for the undervoltage release de-energized electrical signal.
-BB11	= Contact to interrupt the –BB4 signal during the manual opening operation.
-BM	= STU Test unit for supervision of shunt opening release and shunt closing release winding continuity (see note D).
-BS1	= Spring-charging motor limit contacts.
-BS2	= Limit contacts for signalling closing springs charged/discharged.
-MO1	= First shunt opening release (see note D).
-MO2	= Second shunt opening release (see note D).
-MO4	= Third shunt opening release (see note D).
-MC	= Shunt closing release (see note D).
-MS	= Motor for closing spring charging (see note C).
-MU	= Undervoltage release (see note B).
-QB	= Circuit-breaker accessories.
-RL1	= Locking magnet. If de-energized, it mechanically prevents circuit-breaker closing (it is possible to limit its consumption by connecting a delayed pushbutton in series to enable the operation).
-SC	= Pushbutton or contact for circuit-breaker closing.
-SO	= Pushbutton or contact for circuit-breaker opening.
-XB	= Terminal box for the circuit-breaker circuits.
-XB2...16	= Accessory connectors.

Description of figures

Fig. 1	= Motor circuit for closing spring charging (see note C).
Fig. 2	= Shunt closing release (anti-pumping is carried out mechanically) (see note D).
Fig. 3	= Locking magnet. When de-energized, it mechanically prevents circuit-breaker closing. It is possible to limit consumption by connecting a delay pushbutton in series to enable the operation.
Fig. 5	= Instantaneous undervoltage release (see note B).
Fig. 6	= Circuit of third opening release with continuous control of the winding (see note D).
Fig. 7	= Circuit of the first shunt opening release with possibility of continuous control of the winding (see note D).
Fig. 9	= Circuit of the second shunt opening release with possibility of continuous control of the winding (see note D).
Fig. 26	= Electrical signalling of closing springs charged and discharged.
Fig. 30	= Circuit-breaker auxiliary passing contact with momentary closing during circuit-breaker opening.
Fig. 31	= Available circuit-breaker auxiliary contacts.
Fig. 32 ÷ 35	= Available circuit-breaker auxiliary contacts. It is possible to have one of these figures. The standard configuration is figure 32.
Fig. 60	= Contact for the undervoltage release de-energized electrical signal.
Fig. 70 to 73	= Available auxiliary contacts of the circuit-breaker. One of these figures can be obtained.

Selection of the figures

	Description	Figures	Notes
-MS	Spring charging motor	1	C
-MC	Shunt closing release	2	D
-MO1	Shunt opening release	7	D
-MU	Undervoltage release	5	B
-MO2	Additional shunt opening release	9	D
-BB1 -BB2	Set of 10 circuit-breaker auxiliary contacts	31	
	Set of 5 extra circuit-breaker auxiliary contacts 3C-20	32	
	Set of 5 extra circuit-breaker auxiliary contacts 5C	33	
-BB3	Set of 5 extra circuit-breaker auxiliary contacts 2C-30	34	
	Set of 5 extra circuit-breaker auxiliary contacts 50	35	
	Notes: C = normally open contact with circuit-breaker open 0 = normally closed contact with circuit-breaker open		
-RL1	Locking magnet on operating mechanism	3	
-BB4	Transient contact	30	
-BS2	Contact for signalling closing spring charged/discharged	26	
-MO3	Opening solenoid for release outside the circuit-breaker	10	F
-MO4	Third shunt opening release	6	D

Incompatibility

The combination of circuits given in the figures below are not possible on the same circuit-breaker:

32-33-34-35

Notes

- A) The circuit-breaker is only fitted with the accessories specified in the order acknowledgement. To draw up the order, please consult this catalogue.
- B) The undervoltage release can be supplied for power supply branched on the supply side of the circuit-breaker or from an independent source.
Circuit-breaker closing is only possible with the undervoltage release energized (the lock on closing is made mechanically). In the case where there is the same power supply for the shunt closing and undervoltage releases and automatic circuit-breaker closing is required on return of the auxiliary voltage, a delay of 50ms must be introduced between the moment of consent to the undervoltage release and energization of the shunt closing release.
Incompatible with -MO4.
- C) Check the auxiliary circuit power to verify the possibility of starting several motors for charging the closing springs at the same time.
To prevent excessive consumption the closing springs must be charged manually before energizing the auxiliary circuit.
- D) The circuit for controlling the shunt opening release winding continuity must only be used for this purpose.
It is possible to use the STU Test Unit to check continuity of the various release.
- E) When fig. 06 is required, contact -BB3 (41-42) of fig. 32-33 is not available and figs. 34-35 cannot be supplied.
When fig. 09 is required, contact -BB1 (43-44) of fig. 31 is not available.

5. Electric circuit diagram

Electric circuit diagram of withdrawable circuit-breakers 1VCD 400047

The electric circuit diagram given in this section regards the withdrawable circuit-breakers with **breaking capacity up to 40 kA**. For withdrawable circuit-breakers with motorized truck, see diagram 1VCD400048.

For circuit-breaker of ZS8.4 switchgears the following diagrams are available:

- 1VCD400080** Standard version
- 1VCD400085** Version with motorized truck.

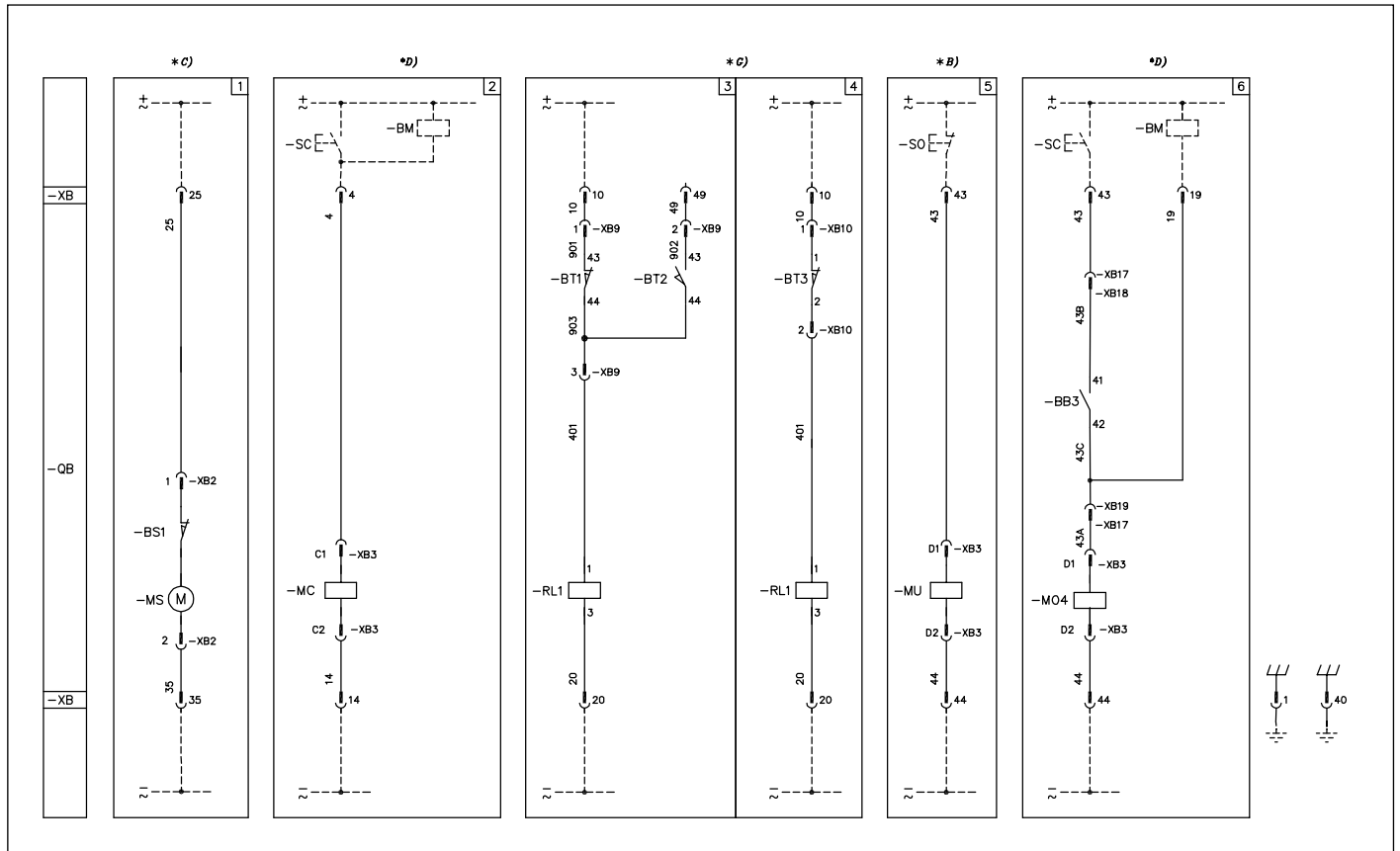

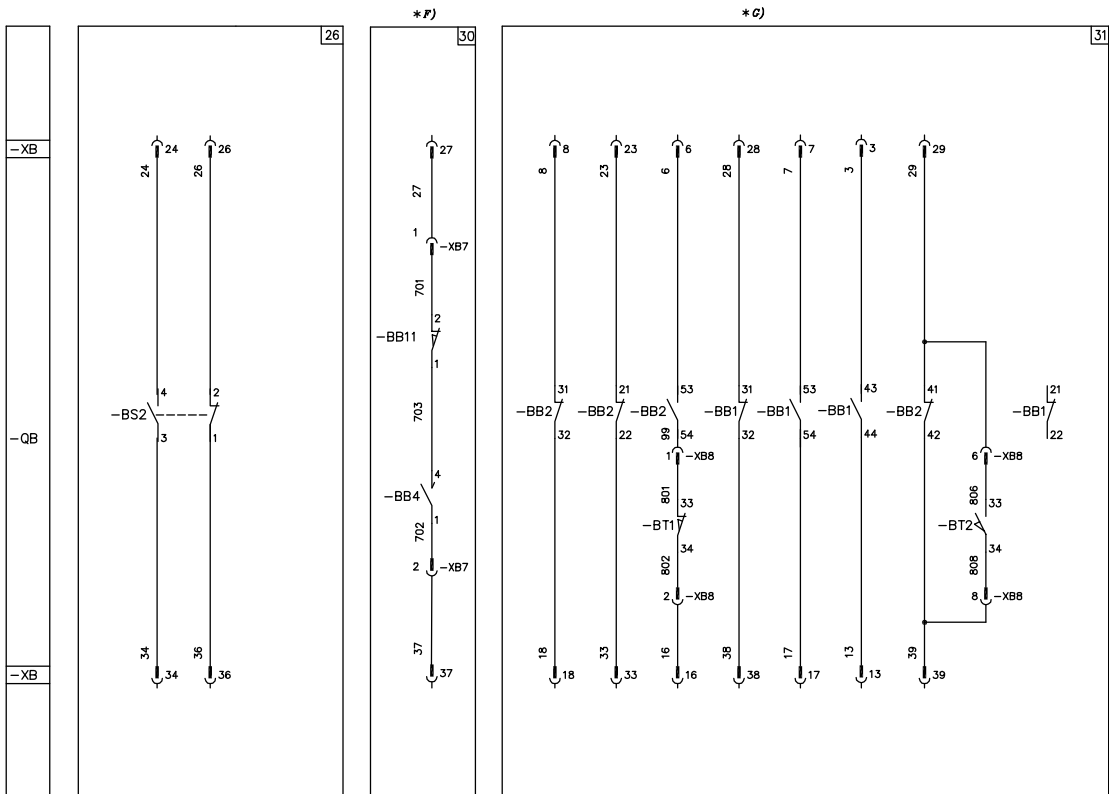
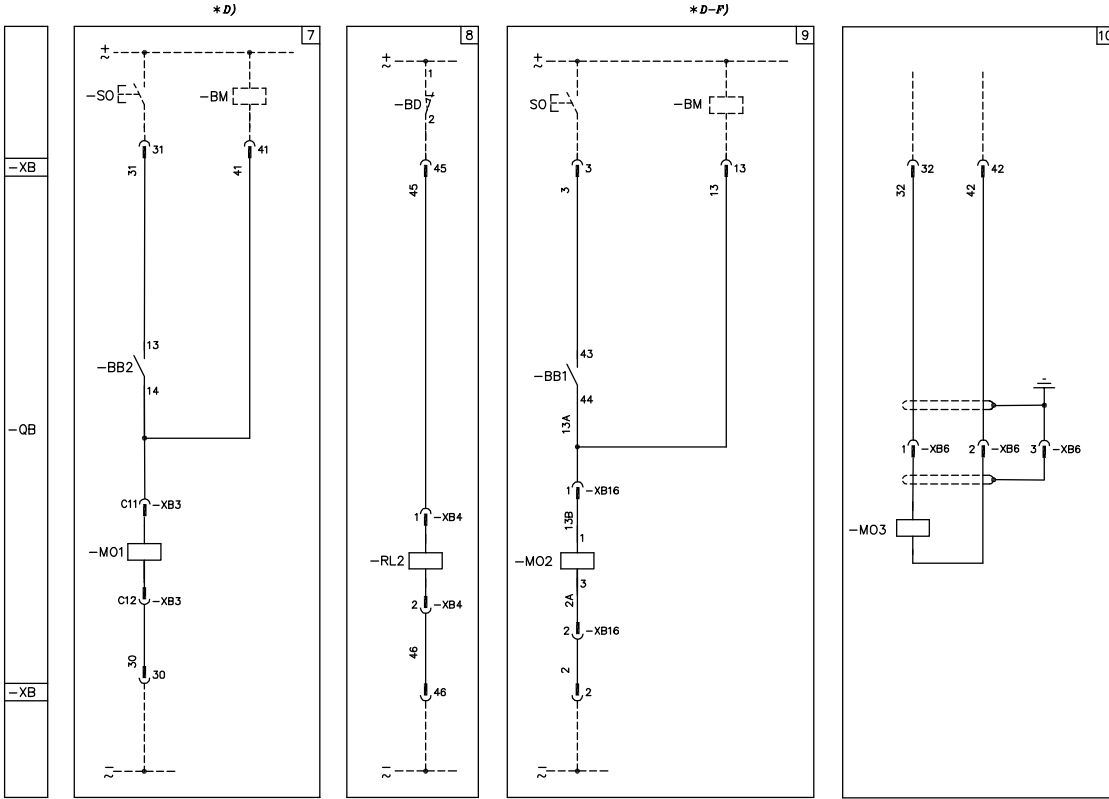

5. Electric circuit diagram

*P)

32

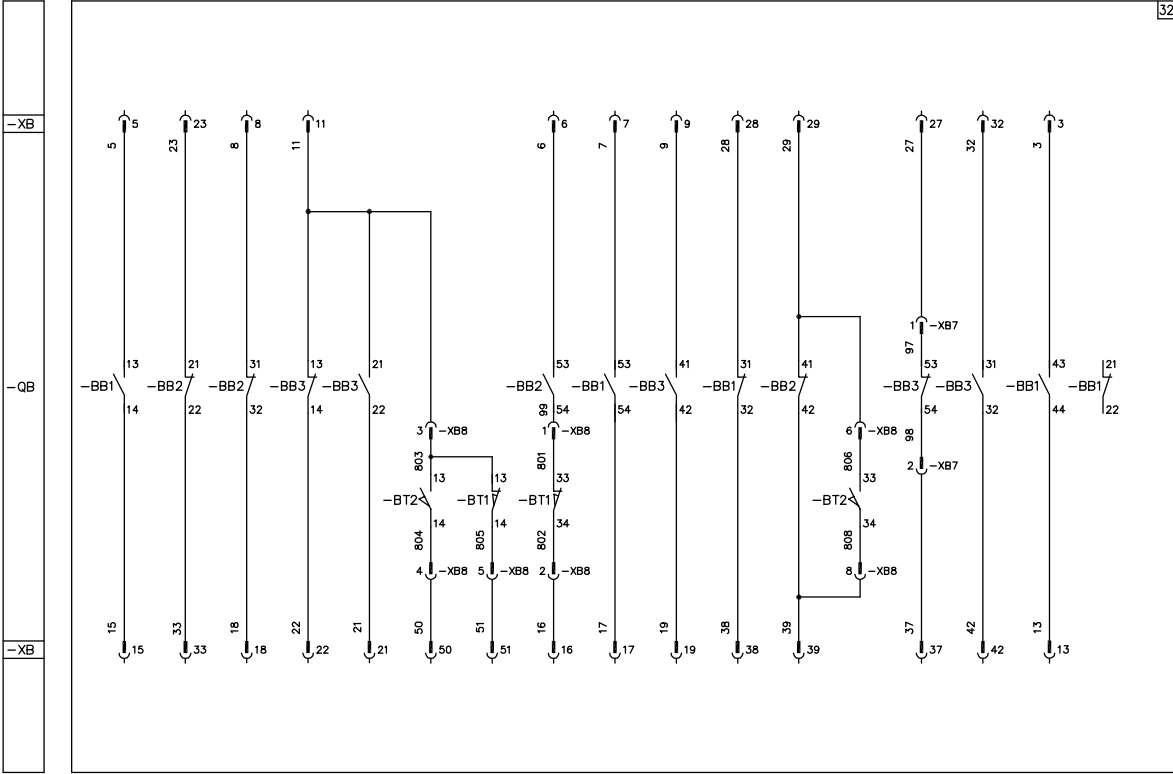

*P)

33

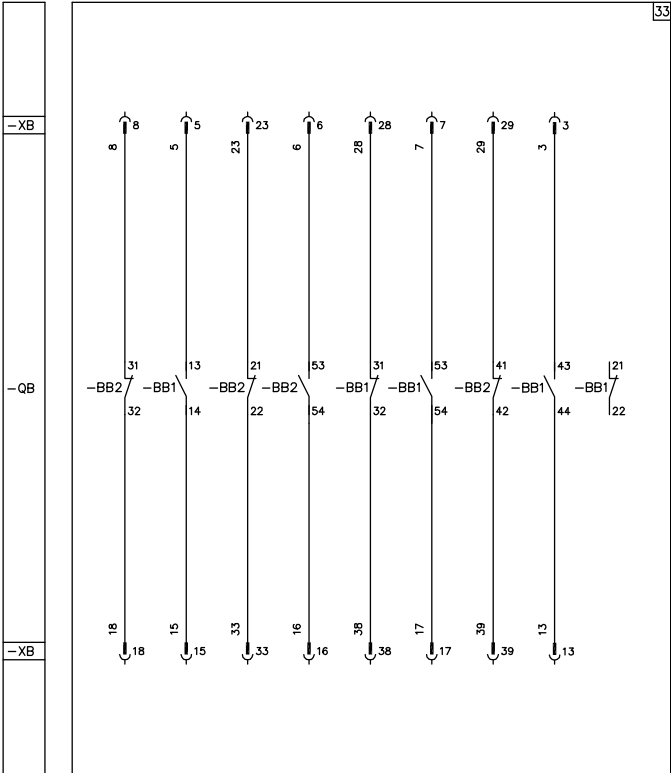

*P)

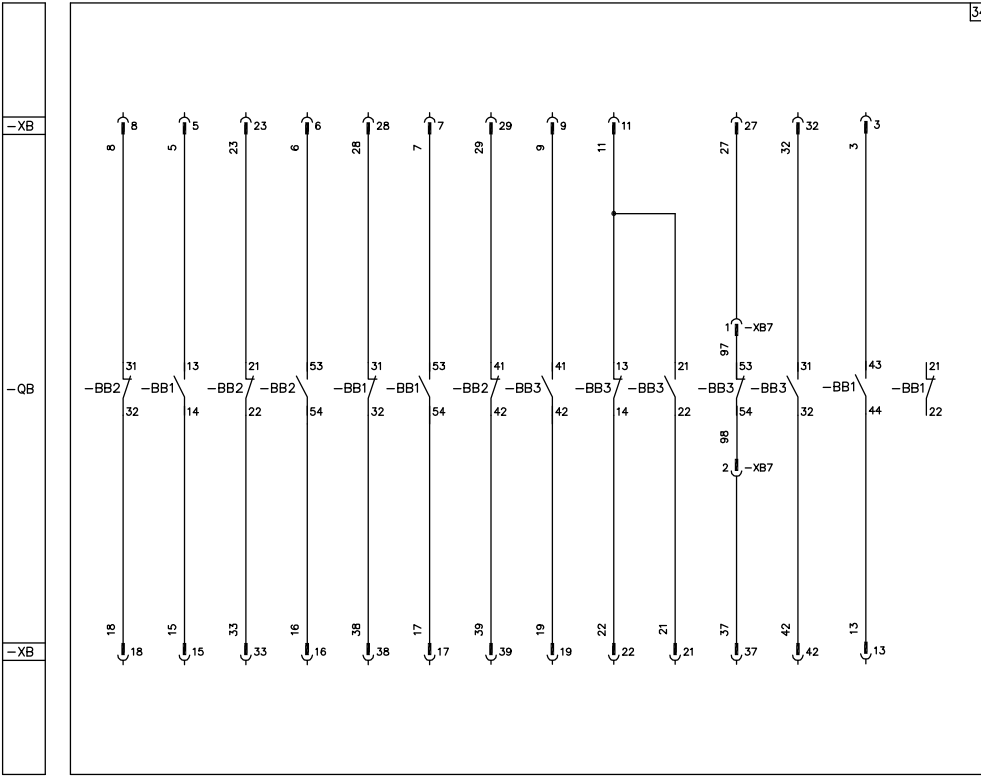

*B)

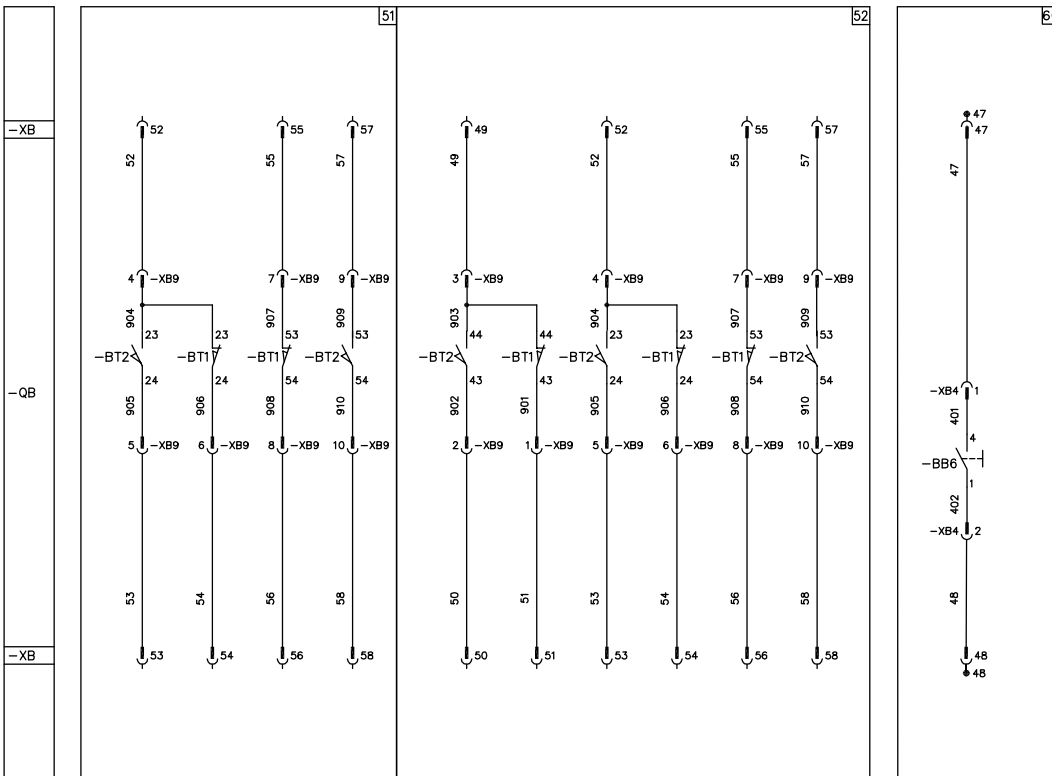

5. Electric circuit diagram

Caption

□	= Reference number of diagram figure.	-MO2	= Second shunt opening release (see note D).
*	= See the note indicated by the letter.	-MO3	= Opening solenoid for release outside the circuit-breaker.
-BB1,..2-3	= Circuit-breaker auxiliary contacts.	-MO4	= Third shunt opening release (see note D).
-BB4	= Circuit-breaker auxiliary passing contact with momentary closing during opening.	-MC	= Shunt closing release (see note D).
-BB6	= Contact for the undervoltage release de-energized electrical signal.	-MS	= Motor for closing spring charging (see note C).
-BB11	= Contact to interrupt the –BB4 signal during the manual opening operation,	-MU	= Undervoltage release (see note B).
-BD	= Enclosure door position contact.	-QB	= Circuit-breaker accessories.
-BM	= STU Test Unit for checking winding continuity of the shunt opening and closing release (see note D).	-RL1	= Locking magnet. If de-energized, it prevents mechanical closing of the circuit-breaker (it is possible to limit its consumption by connecting a delayed pushbutton in series to enable the operation).
-BS1	= Spring-charging motor limit contacts.	-RL2	= Locking magnet (on the truck). If de-energized, it prevents mechanical connection and isolation of the circuit-breaker (it is possible to limit its consumption by connecting a delayed pushbutton in series to enable the operation).
-BS2	= Limit contact for signalling closing springs charged/discharged.	-SC	= Pushbutton or contact for circuit-breaker closing.
-BT1	= Contacts for electrical signalling of circuit-breaker in connected position (see note E).	-SO	= Pushbutton or contact for circuit-breaker opening.
-BT2	= Contacts for electrical signalling of circuit-breaker in isolated position (see note E).	-XB	= Connector for the circuit-breaker circuits.
-BT3	= Circuit-breaker position contact, open during the circuit-breaker isolation run.	-XB2...16	= Accessory connectors.
-MO1	= First shunt opening release (see note D).		

Selection of the figures

	Description	Figures	Notes
-MS	Closing spring charging motor	1	C
-MC	Shunt closing release	2	D
-MO1	Shunt opening release	7	D
-MU	Undervoltage release	5	B
-MO2	Additional shunt opening release	9	D-F
-RL2	Locking magnet on the truck	8	
-BB4	Auxiliary passing contact	30	F
-BS2	Contact for signalling closing spring charged/discharged	26	
-MO3	Opening solenoid for release outside the circuit-breaker	10	F
-MO4	Third shunt opening release	6	D-F

Selection of the figures

Set of 10 circuit-breaker auxiliary contacts -BB1 -BB2	Set of 5 other circuit-breaker auxiliary contacts -BB3	Circuit-breaker connected isolated contact -BT1 -BT2	Position contact for withdrawable circuit-breakers -BT3	Locking magnet on the operating mechanism -RL1	Figures	Notes
X					31	F
X	X				32	F
X		X			31 / 51	E-F
X	X	X			32 / 51	E-F
X		X		X	3 / 31 / 51	E-F-G
X	X	X		X	3 / 32 / 51	E-F-G
X			X	X	4 / 33	E-F-G
X	X		X	X	4 / 34	E-F-G
X		X	X	X	4 / 33 / 52	E-F-G
X	X	X	X	X	4 / 34 / 52	E-F-G

Incompatibility

The circuits given in the figures below cannot be supplied at the same time in the same circuit-breaker:

3-4 **31-32-33-34** **4-31-32** **3-33-34**
31-32-52 **33-34-51** **51-52** **5-6**

Notes

- A) The circuit-breaker is only fitted with the accessories specified in the order acknowledgement. To draw up the order, please consult the present catalogue.
- B) The undervoltage release can be supplied for power supply branched on the supply side of the circuit-breaker or from an independent source. Circuit-breaker closing is only possible with the undervoltage release energized (the lock on closing is made mechanically). In the case where there is the same power supply for the closing and undervoltage releases and automatic circuit-breaker closing is required on return of the auxiliary voltage, a delay of 50ms must be introduced between the moment of consent to the undervoltage release and energization of the shunt closing release.
 Incompatible with -MO4.

- C) Check the power available on the auxiliary circuit to verify the possibility of starting several motors for charging the closing springs at the same time. To prevent excessive consumption the closing springs must be charged manually before energizing the auxiliary circuit.
- D) The circuit for controlling the shunt opening release winding continuity must only be used for this purpose. It is possible to use the STU Shunt Test Unit to check continuity of the winding.
- E) The contacts for electrical signalling of circuit-breaker in the connected and isolated position (-BT1 and -BT2) shown in fig. 51 or 52 are located in the circuit-breaker truck
- F) When fig. 10 is requested, contact -BB3 31-32 indicated of fig. 32-34 is not available. When fig. 30 is requested, contact -BB3 (53-54) indicated of fig. 32-34 is not available. When fig. 9 is requested, contact -BB1 (43-44 indicated) of fig. 31-32-33-34 is not available. When fig. 06 is required, contact -BB3 (terminals 41-42) of figs. 32 and 34 is not available.
- G) Fig. 3 is supplied when fig. 31 or 32 is requested. Fig. 4 is supplied when fig. 33 or 34 is requested (in this case it is compulsory to supply the -BT3).

5. Electric circuit diagram

Electric circuit diagram of withdrawable circuit-breakers 1VCD 400100

The electric circuit diagram given in this section regards the withdrawable circuit-breakers with **breaking capacity up to 50 kA**. For withdrawable circuit-breakers with motorized truck, see diagram 1VCD400102.

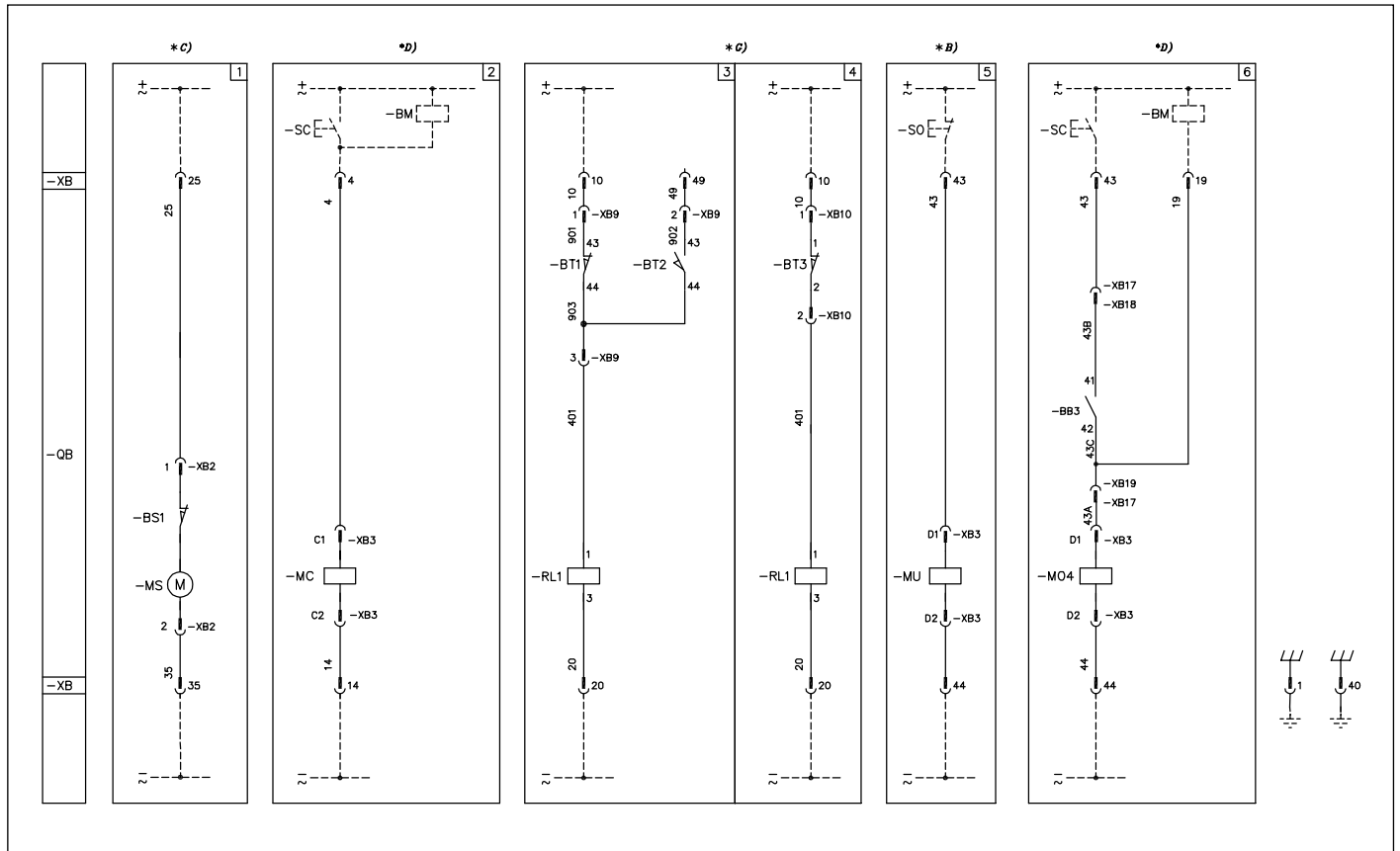

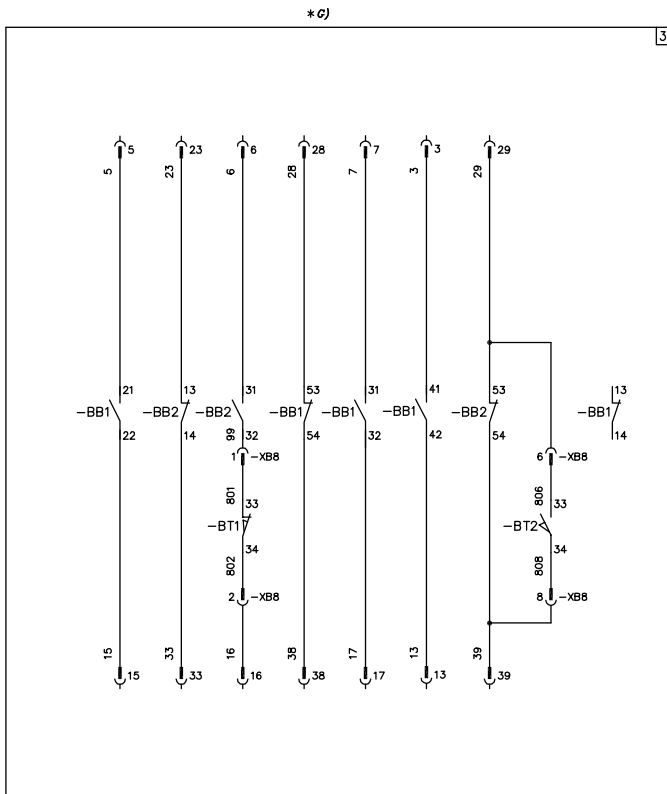
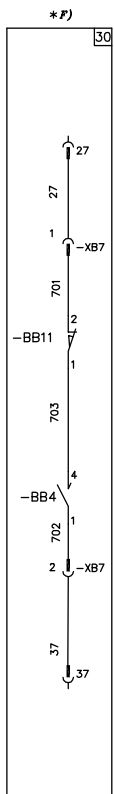
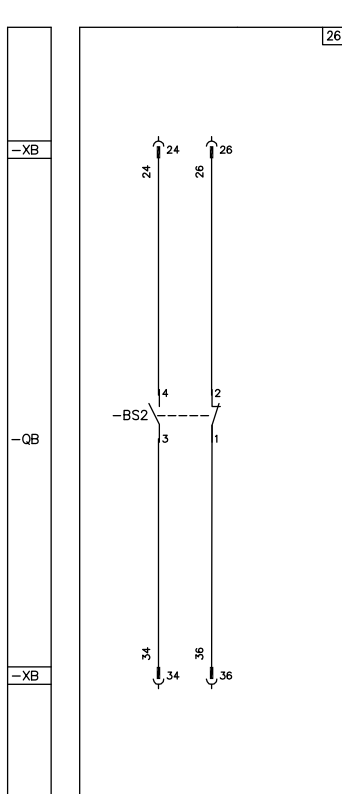
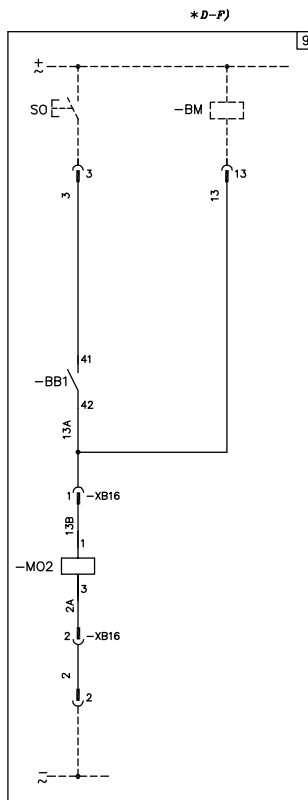
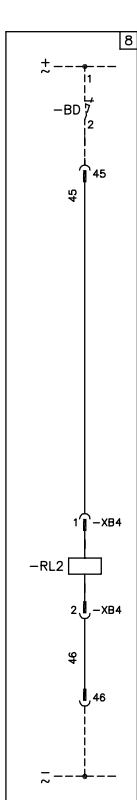
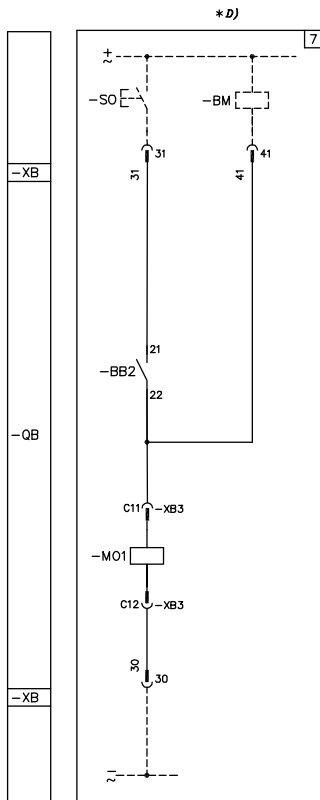

5. Electric circuit diagram

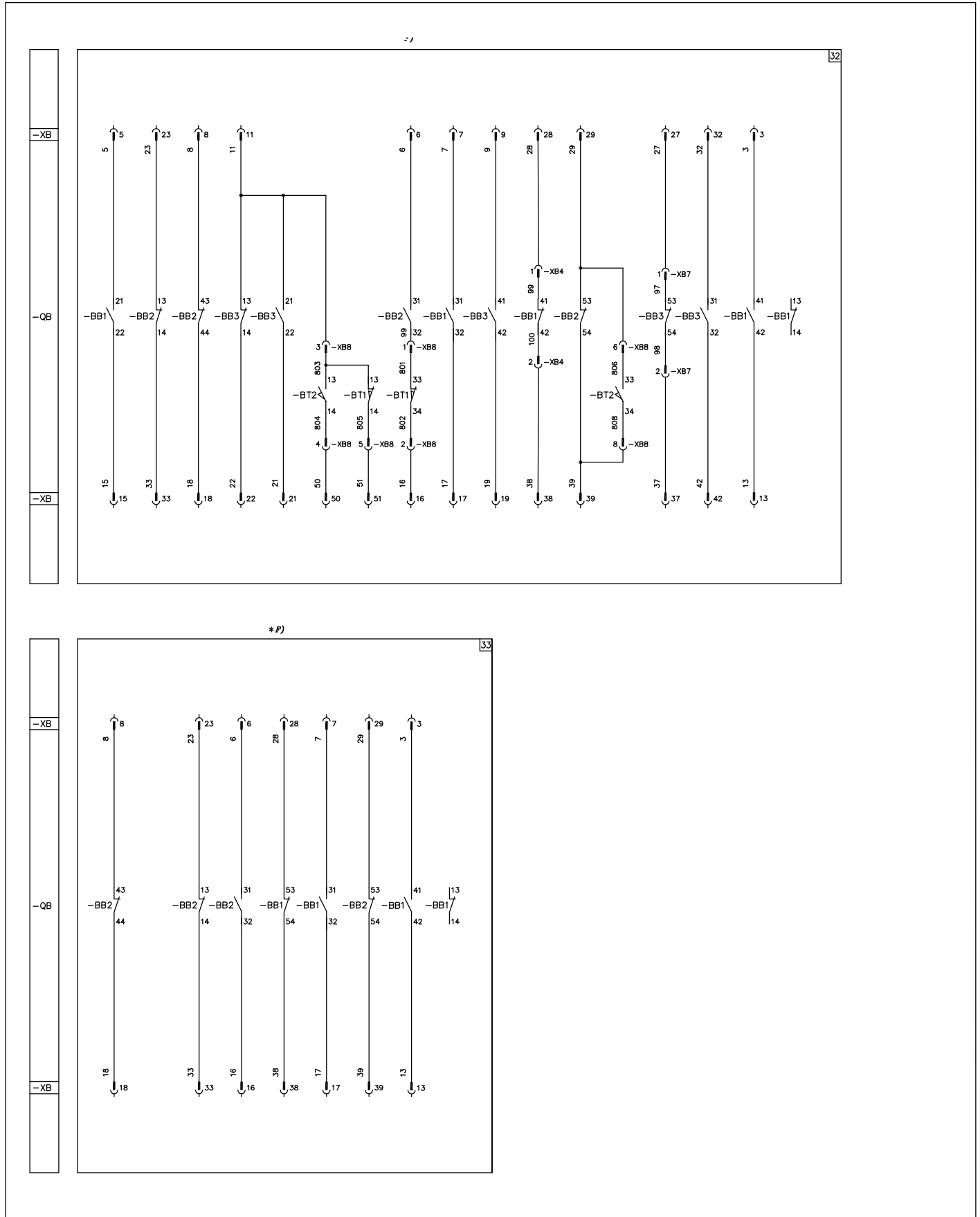

*P)

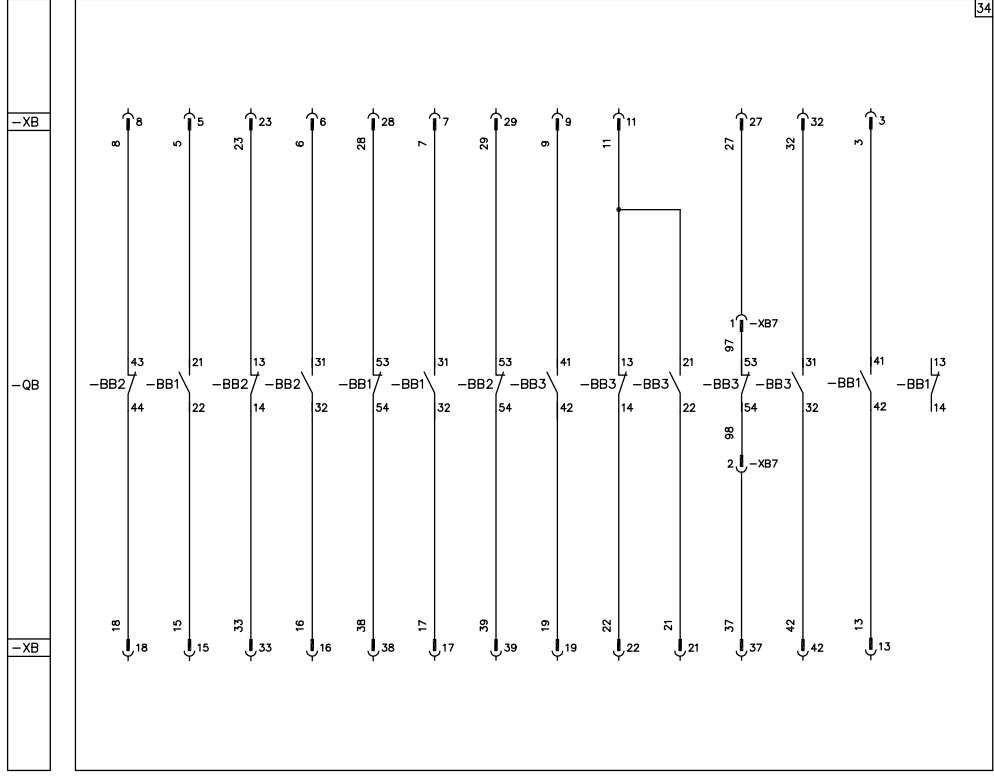

*B)

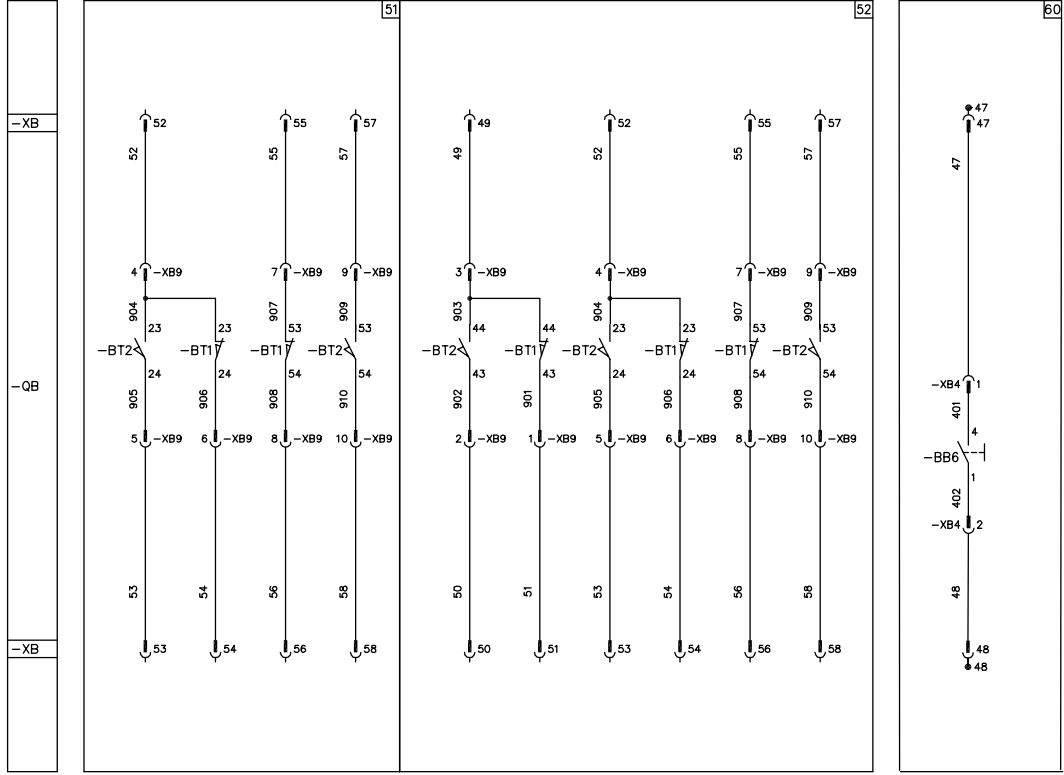

5. Electric circuit diagram

Caption

□	= Reference number of diagram figure.	-MO1	= First shunt opening release (see note D).
*	= See the note indicated by the letter.	-MO2	= Second shunt opening release (see note D).
-BB1,...2-3	= Circuit-breaker auxiliary contacts.	-MO4	= Third shunt opening release (see note D).
-BB4	= Circuit-breaker auxiliary passing contact with momentary closing during opening.	-MC	= Shunt closing release (see note D).
-BB6	= Contact for the undervoltage release de-energized electrical signal	-MS	= Motor for closing spring charging (see note C).
-BB11	= Contact to interrupt the –BB4 signal during the manual opening operation,	-MU	= Undervoltage release (see note B).
-BD	= Enclosure door position contact.	-QB	= Circuit-breaker accessories.
-BM	= STU Test Unit for checking winding continuity of the shunt opening and closing release (see note D).	-RL1	= Locking magnet. If de-energized, it prevents mechanical closing of the circuit-breaker (it is possible to limit its consumption by connecting a delayed pushbutton in series to enable the operation).
-BS1	= Spring-charging motor limit contacts.	-RL2	= Locking magnet (on the truck). If de-energized, it prevents mechanical connection and isolation of the circuit-breaker (it is possible to limit its consumption by connecting a delayed pushbutton in series to enable the operation).
-BS2	= Limit contact for signalling closing springs charged/discharged.	-SC	= Pushbutton or contact for circuit-breaker closing.
-BT1	= Contacts for electrical signalling of circuit-breaker in connected position (see note E).	-SO	= Pushbutton or contact for circuit-breaker opening.
-BT2	= Contacts for electrical signalling of circuit-breaker in isolated position (see note E).	-XB	= Connector for the circuit-breaker circuits.
-BT3	= Circuit-breaker position contact, open during the circuit-breaker isolation run.	-XB2...16	= Accessory connectors.

Selection of the figures

	Description	Figures	Notes
-MS	Closing spring charging motor	1	C
-MC	Shunt closing release	2	D
-MO1	Shunt opening release	7	D
-MU	Undervoltage release	5	B
-MO2	Additional shunt opening release	9	D-F
-RL2	Locking magnet on the truck	8	
-BB4	Auxiliary passing contact	30	F
-BS2	Contact for signalling closing spring charged/discharged	26	
-MO4	Third shunt opening release	6	D-F

Selection of the figures

Set of 10 circuit-breaker auxiliary contacts -BB1 -BB2	Set of 5 other circuit-breaker auxiliary contacts -BB3	Circuit-breaker connected isolated contact -BT1 -BT2	Position contact for withdrawable circuit-breakers -BT3	Locking magnet on the operating mechanism -RL1	Figures	Notes
X					31	F
X	X				32	F
X		X			31 / 51	E-F
X	X	X			32 / 51	E-F
X		X		X	3 / 31 / 51	E-F-G
X	X	X		X	3 / 32 / 51	E-F-G
X			X	X	4 / 33	E-F-G
X	X		X	X	4 / 34	E-F-G
X		X	X	X	4 / 33 / 52	E-F-G
X	X	X	X	X	4 / 34 / 52	E-F-G

Incompatibility

The circuits given in the figures below cannot be supplied at the same time in the same circuit-breaker:

3-4 **31-32-33-34** **4-31-32** **3-33-34**
31-32-52 **31-34-51** **51-52** **5-6**

Note

- A) The circuit-breaker is only fitted with the accessories specified in the order acknowledgement. To draw up the order, please consult the apparatus catalogue.
- B) The undervoltage release can be supplied for power supply branched on the supply side of the circuit-breaker or from an independent source.
 Circuit-breaker closing is only possible with the undervoltage release energized (the lock on closing is made mechanically).
 In the case where there is the same power supply for the closing and undervoltage releases and automatic circuit-breaker closing is required on return of the auxiliary voltage, a delay of 50ms must be introduced between the moment of consent to the undervoltage release and energization of the shunt closing release.
 Incompatible with -MO4

- C) Check the power available on the auxiliary circuit to verify the possibility of starting several motors for charging the closing springs at the same time. To prevent excessive consumption the closing springs must be charged manually before energizing the auxiliary circuit.
- D) The circuit for controlling the shunt opening release winding continuity must only be used for this purpose.
 It is possible to use the Shunt Test Unit to check continuity of the winding.
- E) The contacts for electrical signalling of circuit-breaker in the connected and isolated position (-BT1 and -BT2) shown in fig. 51 or 52 are located in the circuit-breaker truck
- F) When fig. 9 is required, contact -BB1 (terminals 41-42) of figs. 31-32-33-34 is not available. When fig. 30 is required, contact -BB3 (terminals 53-54) of figs. 32 and 34 is not available. When fig. 06 is required, contact -BB3 (terminals 41-42) of figs. 32-34 is not available.
- G) Fig. 3 is supplied when fig. 31 or 32 are required. Fig. 4 is supplied when fig. 33 or 34 are required (in this case, it is obligatory for -BT3 to be supplied).

Contact us

ABB S.p.A.

Power Products Division Unità Operativa Sace-MV

Via Friuli, 4

I-24044 Dalmine

Tel.: +39 035 6952 111

Fax: +39 035 6952 874

e-mail: info.mv@it.abb.com

ABB AG

Calor Emag Medium Voltage Products

Oberhausener Strasse 33 Petzower Strasse 8

D-40472 Ratingen D-14542 Gliindow

Phone: +49(0)2102/12-1230, Fax: +49(0)2102/12-1916

E-mail: powertech@de.abb.com

www.abb.com

The data and illustrations are not binding. We reserve the right to make changes without notice in the course of technical development of the product.

© Copyright 2012 ABB. All rights reserved.