

VD4/R - VD4/L - VD4/UniAir - VD4/UniMix - VD4/R-SEC - VD4/L-SEC

Installation and operating instructions

12...24 kV - 630...1250 A - 12...25 kA

I.	Foreword	4
II.	Environmental protection program	5
1.	Packing and transport	6
2.	Inspection on arrival	7
3.	Storing	8
4.	Handling	9
5.	Description	10
5.1	General	10
5.2	Reference Standards	11
5.3	Fixed circuit-breakers	11
5.4	Standard equipment	19
5.5	Available types	21
5.6	Characteristics of the electrical accessories	26
6.	Instructions for circuit-breaker operation	27
6.1	Safety indications	27
6.2	Operating and signalling parts	27
6.3	Circuit-breaker closing and opening operations	28
7.	Installation	29
7.1	General	29
7.2	Installation and operating conditions	29
7.3	Preliminary operations	30
7.4	Installation of fixed circuit-breakers	30
7.5	Installation of circuit-breakers for ABB switchgear	30
7.6	Power circuit connections	30
7.7	Earthing	31
7.8	Connection of the auxiliary circuits	31
8.	Putting into service	32
8.1	General procedures	32
9.	Maintenance	33
9.1	General	33
9.2	Inspections and functionality tests	33
9.3	Overhaul	34
9.4	Repairs section	34
10.	Application of the X-ray emission Standards	36
11.	Spare parts and accessories	37
11.1	List of spare parts	37
12.	Overall dimensions	38
13.	Quality of the products and environmental protection	52



For your safety!

- Make sure that the installation room (space, divisions and environment) is suitable for the electrical apparatus.
- Make sure that all the installation, putting into service and maintenance operations are carried out by skilled personnel with in-depth knowledge of the equipment.
- Make sure that all the installation, service and maintenance operations comply with the standards and laws so as to ensure that the installations are constructed in accordance with the rules of good workmanship and safety in the work place.
- Strictly comply with the instructions in this manual.
- Make sure that the rated performance of the apparatus is not exceeded during service.
- Make sure that the personnel are provided with this manual and are aware of all the relevant information while operating on the apparatus.
- Pay special attention to the information in the manual highlighted by the following symbol:



Responsible behaviour safeguards your own and others' safety!
Please contact the ABB Assistance Service for any further requirements.

I. Foreword

This publication contains the information required for installing the following medium voltage circuit-breakers and putting them into service: VD4/R - VD4/L - VD4/UniAir - VD4/UniMix, VD4/S, VD4/R-SEC and VD4/L-SEC, hereinafter called VD4.

Please read the manual carefully to ensure that the product is used correctly.

Similarly to all the apparatus we manufacture, the VD4 circuit-breakers are also designed for different installation configurations.

However, these devices can be subjected to further technical-construction modifications (at the customer's request) so as to adapt them to special installation requirements.

Consequently, the manual may not contain instructions concerning special customized configurations.

Besides this manual, it is therefore always necessary to consult the latest technical documentation (electric circuit and wiring diagrams, assembly and installation drawings, any protection coordination studies, etc.), especially regarding any variants requested in relation to the standard configurations.

Only use original spare parts for maintenance operations.

Please also consult the technical catalogue of the circuit-breaker and the spare parts catalogue for further details.



All the installation, putting into service, running and maintenance operations must be carried out by suitably qualified personnel with in-depth knowledge of the apparatus.

II. Environmental protection program

The VD4 circuit-breakers are manufactured in compliance with Standard ISO 14000 (Environmental management guidelines). The manufacturing processes are implemented in accordance with the environmental protection standards when it comes to reducing both energy consumption and the production of waste. All this is thanks to the environmental management system applied in the medium voltage apparatus manufacturing facility.

1. Packing and transport

The circuit-breaker is shipped in special packing, in the open position and with the springs discharged.

Each piece of apparatus is protected by a plastic cover to prevent water from infiltrating during the loading and unloading stages and to keep the dust off during storage.

2. Inspection on arrival



Before proceeding with any operation, always make sure that the springs of the operating mechanism are discharged and that the apparatus is in the open position.

Upon arrival, check the condition of the apparatus, that the packing is undamaged and that the nameplate data (see fig. 1) correspond to the information in the order confirmation and shipping note.

Also make sure that all the materials described in the shipping note are included in the supply.

Should any damage or irregularity be noted in the supply on unpacking, notify ABB (directly or through the agent or supplier) as soon as possible and in any case within five days of receipt.

The apparatus is only supplied with the accessories specified at the time of ordering and validated in the order confirmation sent by ABB.

The following documents accompany the apparatus when it is shipped:

- instruction manual (this document)
- test certificate
- identification label
- copy of the shipping documents
- wiring diagram.

Other documents, sent prior to shipment of the apparatus, are:

- order confirmation
- original shipping notification
- any drawings or documents referring to special configurations/conditions.

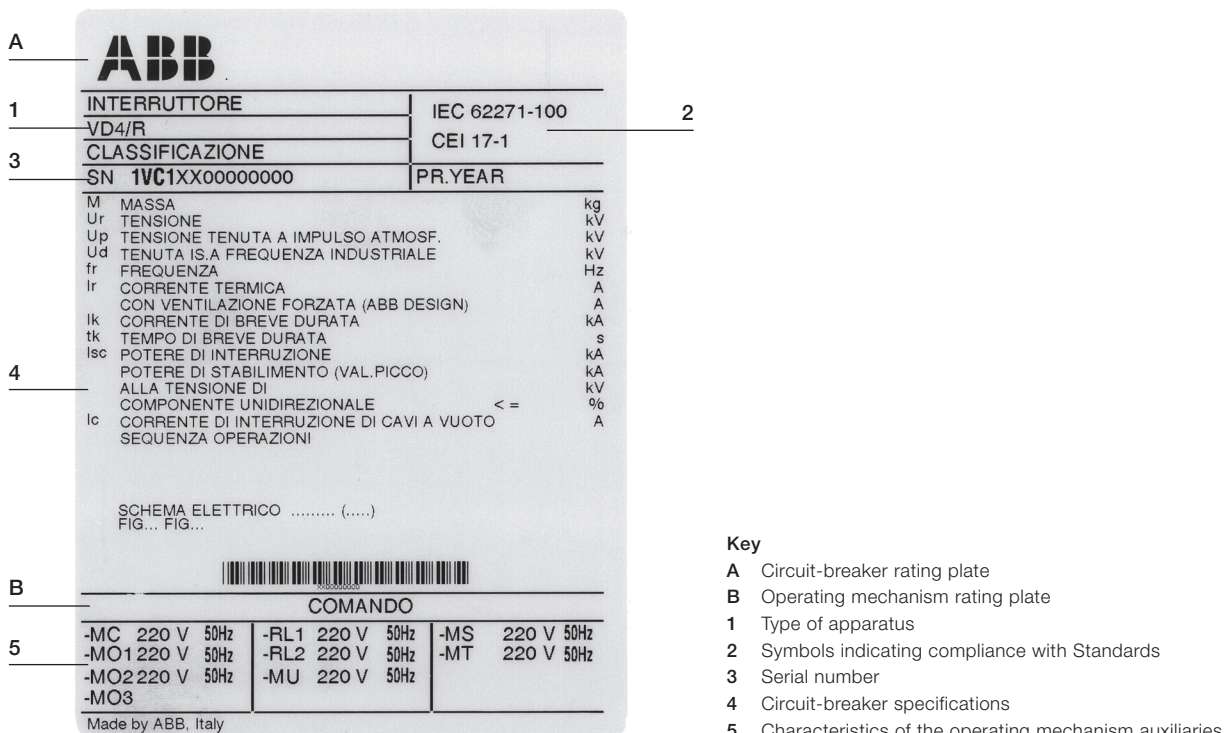

Figure 1

3. Storing

When the apparatus must be stored for a certain period of time, our workshops can (on request) provide suitable packing for the specified storage conditions.

On arrival, the apparatus must be carefully unpacked and checked as described in the Checking on arrival section (chap. 2).

If the apparatus cannot be installed immediately, it must be repacked in the original packing materials.

Insert at least one standard packet of special hygroscopic sub-

stance per piece of apparatus inside the packing.

Should the original packing no longer be available and the apparatus cannot be installed immediately, it should be stored indoors in a well-ventilated, dry, dust-free, noncorrosive environment, well away from any easily flammable materials and at a temperature between -5 °C and +40 °C.

Avoid any accidental impact or positions which stress the structure of the apparatus.

4. Handling

Before proceeding with any operation, always make sure that the springs of the operating mechanism spring are discharged and that the apparatus is in the open position.

When handling the apparatus, take great care to prevent the insulating parts and the terminals of the circuit-breaker from being stressed.



The apparatus must not be handled by inserting lifting devices directly under the apparatus itself. If this technique is unavoidable, place the circuit-breaker on a pallet or a sturdy supporting surface (see fig. 2).

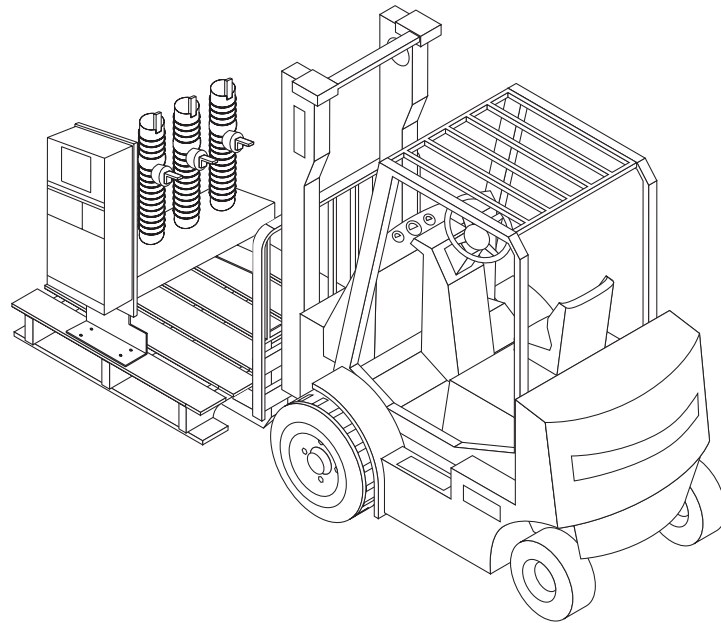

Figure 2

5. Description

5.1 General

VD4 series circuit-breakers are devices under vacuum for indoor installation. Please refer to the corresponding technical catalogue code 1VCP000263 for the relative electrical performance. Please contact ABB for special installation requirements.

VD4 series medium voltage vacuum circuit-breakers with lateral operating mechanism for indoor installation feature the separate pole construction technique.

Each pole houses a vacuum interrupter which is encased in the resin when the cylinder is moulded thanks to a special manufacturing process.

This construction method protects the vacuum interrupter from shock, pollution and condensation.

The operating mechanism is the EL trip-free stored energy type with independent opening and closing regardless of the operator's action. The EL operating mechanism is widely used in all VD4 series circuit-breakers with frontal control.

The circuit-breaker can be remote controlled when fitted with dedicated electrical accessories (gearmotor, opening and closing release).

The operating mechanism, the three poles and the current sensors (if provided) are installed on a metal frame without wheels. The construction is particularly compact, sturdy and of limited weight.

VD4 series circuit-breakers with lateral operating mechanisms are life-long sealed pressure devices (Standards IEC 62271-100 and CEI-EN 62271-100).

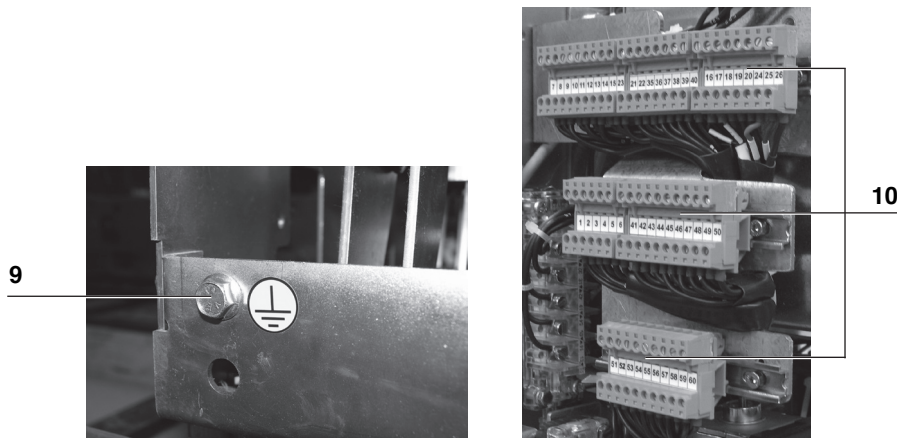
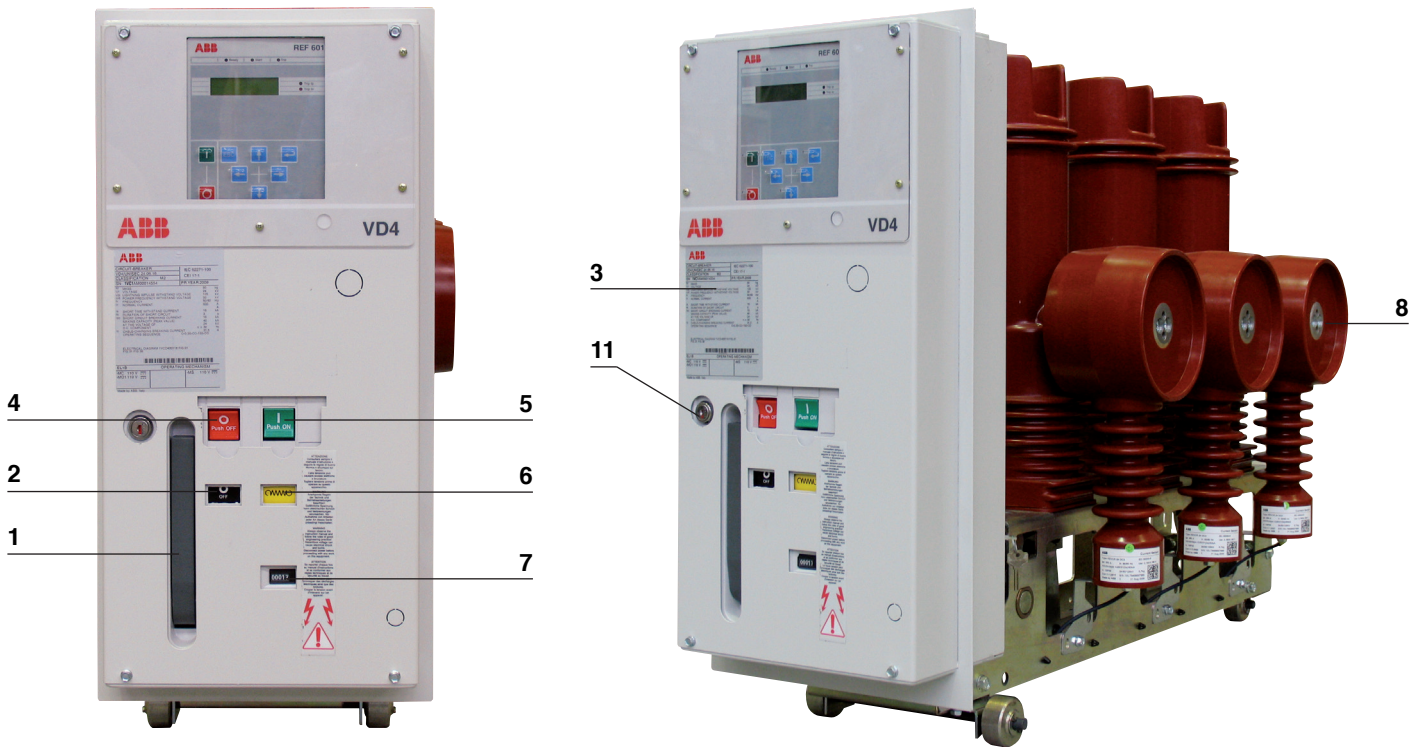

Key

- 1 Lever for loading the closing springs in the manual mode
- 2 Circuit-breaker open/closed indicator
- 3 Rating plate
- 4 Opening pushbutton
- 5 Closing pushbutton
- 6 Signalling device for closing springs loaded/discharged
- 7 Operation counter
- 8 Terminals
- 9 Earthing screw
- 10 Delivery terminal box
- 11 Key lock (circuit-breaker open) (*)

(*) **Warning!** To activate the key lock: open the circuit-breaker, keep the opening pushbutton depressed, then turn the key and remove it from the housing.

Figure 3

5.1.1 Available versions

VD4 circuit-breakers with lateral operating mechanism are available in the following versions:

- fixed, with rh lateral operating mechanism and 230 mm pole center-distance
- fixed, with lh lateral operating mechanism and 230 mm pole center-distance
- fixed, with rh lateral operating mechanism and 300 mm pole center-distance
- fixed, with lh lateral operating mechanism and 300 mm pole center-distance
- removable, with rh lateral operating mechanism, version for UniSwitch switchgear, 210 mm pole center-distance
- removable, with rh lateral operating mechanism, version for UniMix switchgear, 230 mm pole center-distance
- removable, with rh lateral operating mechanism, version for UniAir switchgear, 300 mm pole center-distance
- removable, with rh lateral operating mechanism, version for UniSec switchgear, 230 mm pole center-distance
- removable, with lh lateral operating mechanism, version for UniSec switchgear, 230 mm pole center-distance.

Depending on the version, they can be equipped on request with two or three current sensors and with a PR521 series or REF 601 series device for protection against overcurrents.

5.2 Reference Standards

The VD4 circuit-breakers conform to standards IEC 62271-100, CEI-EN 62271-100 (dossier 7642) and those of the major industrialized countries.

5.3 Fixed circuit-breakers

The fixed circuit-breaker (fig. 4) is the basic version complete with structure and front protection shield. There are two drilled supports in the lower part of the structure to allow the circuit-breaker to be fixed.

The terminal box (10) is available for the electrical connections of the circuit-breaker's auxiliary circuits.

The earthing screw is located in the rear part of the circuit-breaker. See the key to figure 4 for further details.

5.3.1 General specifications of fixed circuit-breakers with rh lateral operating mechanisms (12 - 17.5 - 24 kV)

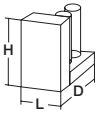
Circuit-breaker		VD4/R 12			VD4/R 17			VD4/R 24			
Standards	IEC 62271-100	•			•			•			
	CEI EN 62271-100 (dossier 7642)	•			•			•			
Rated voltage	Ur [kV]	12			17.5			24			
Rated insulation voltage	Us [kV]	12			17.5			24			
Withstand voltage at 50 Hz	Ud (1 min) [kV]	28			38			50			
Impulse withstand voltage	Up [kV]	75			95			125			
Rated frequency	fr [Hz]	50-60			50-60			50-60			
Rated thermal current (40 °C)	Ir [A]	630	800	1250	630	800	1250	630	800	1250	
Rated duty breaking capacity (symmetrical rated short-circuit current)	Isc [kA]	12.5	-	-	12.5	-	-	12.5	-	-	
		16	16	16	16	16	16	16	16	16	
		20	20	20	20	20	20	20	20	20	
		25	25	25	25	25	25	-	-	-	
Short-time withstand current (3 s)	Ik [kA]	12.5	-	-	12.5	-	-	12.5	-	-	
		16	16	16	16	16	16	16	16	16	
		20	20	20	20	20	20	20	20	20	
		25	25	25	25	25	25	-	-	-	
Making capacity	Ip [kA]	31.5	-	-	31.5	-	-	31.5	-	-	
		40	40	40	40	40	40	40	40	40	
		50	50	50	50	50	50	50	50	50	
		63	63	63	63	63	63	-	-	-	
Sequence of operations	[O - 0.3s - CO - 15s - CO]	•			•			•			
Opening time	[ms]	40...60			40...60			40...60			
Arcing time	[ms]	10...15			10...15			10...15			
Total break-time	[ms]	50...75			50...75			50...75			
Closing time	[ms]	30...60			30...60			30...60			
Overall dimensions (maximum)		H [mm]	785			785			785		
		L [mm]	317			317			317		
		D [mm]	1029 ⁽¹⁾ / 1170 ⁽²⁾			1029 ⁽¹⁾ / 1170 ⁽²⁾			1029 ⁽¹⁾ / 1170 ⁽²⁾		
		Pole center-distance l [mm]	230 / 300			230 / 300			230 / 300		
Weight ⁽³⁾	[kg]	65 ⁽¹⁾ - 67 ⁽²⁾			65 ⁽¹⁾ - 67 ⁽²⁾			65 ⁽¹⁾ - 67 ⁽²⁾			
Application of PR521 protection device	In [A]	40 - 80 - 250 - 1250 ⁽⁴⁾			40 - 80 - 250 - 1250 ⁽⁴⁾			40 - 80 - 250 - 1250 ⁽⁴⁾			
Application of REF 601 protection device ⁽⁶⁾		• ⁽⁵⁾			• ⁽⁵⁾			• ⁽⁵⁾			
Standardized dimensions table		1VCD000100 ⁽¹⁾			1VCD000100 ⁽¹⁾			1VCD000100 ⁽¹⁾			
		1VCD000101 ⁽²⁾			1VCD000101 ⁽²⁾			1VCD000101 ⁽²⁾			
Wiring diagram	without protection device installed	1VCD400097			1VCD400097			1VCD400097			
	with PR521	1VCD400097			1VCD400097			1VCD400097			
	with REF 601	1VCD400115			1VCD400115			1VCD400115			
Operating temperature	[°C]	-5 ... +40 ⁽⁷⁾			-5 ... +40 ⁽⁷⁾			-5 ... +40 ⁽⁷⁾			
Tropicalization	IEC: 60068-2-30, 60721-2-1	•			•			•			
Electromagnetic compatibility	IEC 62271-1	•			•			•			

⁽¹⁾ 230 mm pole center-distance

⁽²⁾ 300 mm pole center-distance

⁽³⁾ increase the indicated weight by 20 kg for circuit-breakers with PR521 / REF 601 devices and 3 current sensors

⁽⁴⁾ rated current of the current sensors (the PR521 device and the current sensors are available on request)

⁽⁵⁾ the rated current of the REF 601 device must be set in the relay in accordance with the circuit-breaker's rated current

⁽⁶⁾ "IEC" or "CEI 0-16" version. If the "CEI 0-16" is required, the circuit-breaker is always supplied with 3 phase current sensors (Rogowsky coils) installed on the actual circuit-breaker and with a loose toroidal TA. In the "CEI 0-16" version, the REF 601 device opens the circuit-breaker by means of the undervoltage release - MU

⁽⁷⁾ for operating temperature up to -25 °C and storage temperature up to -40 °C, please ask ABB

5.3.2 General specifications of fixed circuit-breakers with lh lateral operating mechanisms (12 - 17.5 - 24 kV)

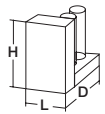
Circuit-breaker		VD4/L 12			VD4/L 17			VD4/L 24			
Standards	IEC 62271-100	●			●			●			
	CEI EN 62271-100 (dossier 7642)	●			●			●			
Rated voltage	Ur [kV]	12			17.5			24			
Rated insulation voltage	Us [kV]	12			17.5			24			
Withstand voltage at 50 Hz	Ud (1 min) [kV]	28			38			50			
Impulse withstand voltage	Up [kV]	75			95			125			
Rated frequency	fr [Hz]	50-60			50-60			50-60			
Rated thermal current (40 °C)	Ir [A]	630	800	1250	630	800	1250	630	800	1250	
Rated duty breaking capacity (symmetrical rated short-circuit current)	Isc [kA]	12.5	-	-	12.5	-	-	12.5	-	-	
		16	16	16	16	16	16	16	16	16	
		20	20	20	20	20	20	20	20	20	
		25	25	25	25	25	25	-	-	-	
Short-time withstand current (3 s)	Ik [kA]	12.5	-	-	12.5	-	-	12.5	-	-	
		16	16	16	16	16	16	16	16	16	
		20	20	20	20	20	20	20	20	20	
		25	25	25	25	25	25	-	-	-	
Making capacity	Ip [kA]	31.5	-	-	31.5	-	-	31.5	-	-	
		40	40	40	40	40	40	40	40	40	
		50	50	50	50	50	50	50	50	50	
		63	63	63	63	63	63	-	-	-	
Sequence of operations	[O - 0.3s - CO - 15s - CO]	●			●			●			
Opening time	[ms]	40...60			40...60			40...60			
Arcing time	[ms]	10...15			10...15			10...15			
Total break-time	[ms]	50...75			50...75			50...75			
Closing time	[ms]	30...60			30...60			30...60			
Overall dimensions (maximum)		H [mm]	785			785			785		
		L [mm]	317			317			317		
		D [mm]	1029 ⁽¹⁾ / 1170 ⁽²⁾			1029 ⁽¹⁾ / 1170 ⁽²⁾			1029 ⁽¹⁾ / 1170 ⁽²⁾		
		Pole center-distance I [mm]	230 / 300			230 / 300			230 / 300		
Weight ⁽³⁾	[kg]	65 ⁽¹⁾ - 67 ⁽²⁾			65 ⁽¹⁾ - 67 ⁽²⁾			65 ⁽¹⁾ - 67 ⁽²⁾			
Application of PR521 protection device	In [A]	40 - 80 - 250 - 1250 ⁽⁴⁾			40 - 80 - 250 - 1250 ⁽⁴⁾			40 - 80 - 250 - 1250 ⁽⁴⁾			
Application of REF 601 protection device ⁽⁶⁾		● ⁽⁵⁾			● ⁽⁵⁾			● ⁽⁵⁾			
Standardized dimensions table		1VCD003453 ⁽¹⁾			1VCD003453 ⁽¹⁾			1VCD003453 ⁽¹⁾			
		1VCD003454 ⁽²⁾			1VCD003454 ⁽²⁾			1VCD003454 ⁽²⁾			
Wiring diagram	without protection device installed	1VCD400097			1VCD400097			1VCD400097			
	with PR521	1VCD400097			1VCD400097			1VCD400097			
	with REF 601	1VCD400115			1VCD400115			1VCD400115			
Operating temperature	[°C]	-5 ... +40 ⁽⁷⁾			-5 ... +40 ⁽⁷⁾			-5 ... +40 ⁽⁷⁾			
Tropicalization	IEC: 60068-2-30, 60721-2-1	●			●			●			
Electromagnetic compatibility	IEC 62271-1	●			●			●			

⁽¹⁾ 230 mm pole center-distance

⁽²⁾ 300 mm pole center-distance

⁽³⁾ increase the indicated weight by 20 kg for circuit-breakers with PR521 / REF 601 devices and 3 current sensors

⁽⁴⁾ rated current of the current sensors (the PR521 device and the current sensors are available on request)

⁽⁵⁾ the rated current of the REF 601 device must be set in the relay in accordance with the circuit-breaker's rated current

⁽⁶⁾ "IEC" or "CEI 0-16" version. If the "CEI 0-16" is required, the circuit-breaker is always supplied with 3 phase current sensors (Rogowsky coils) installed on the actual circuit-breaker and with a loose toroidal TA. In the "CEI 0-16" version, the REF 601 device opens the circuit-breaker by means of the undervoltage release - MU

⁽⁷⁾ for operating temperature up to -25 °C and storage temperature up to -40 °C, please ask ABB

5.3.3 General specifications of fixed circuit-breakers with rh lateral operating mechanisms for ABB UniSwitch switchgear (12 - 17.5 - 24 kV)

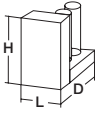
Circuit-breaker		VD4/S 12			VD4/S 17			VD4/S 24			
Standards	IEC 62271-100	•			•			•			
	CEI EN 62271-100 (dossier 7642)	•			•			•			
Rated voltage	Ur [kV]	12			17.5			24			
Rated insulation voltage	Us [kV]	12			17.5			24			
Withstand voltage at 50 Hz	Ud (1 min) [kV]	28			38			50			
Impulse withstand voltage	Up [kV]	75			95			125			
Rated frequency	fr [Hz]	50-60			50-60			50-60			
Rated thermal current (40 °C)	Ir [A]	630	800	1250	630	800	1250	630	800	1250	
Rated duty breaking capacity (symmetrical rated short-circuit current)	Isc [kA]	12.5	12.5	12.5	12.5	12.5	12.5	12.5	12.5	12.5	
		16	16	16	16	16	16	16	16	16	
		20	20	20	20	20	20	20	20	20	
		25	25	25	–	–	–	–	–	–	
Short-time withstand current (3 s)	Ik [kA]	12.5	12.5	12.5	12.5	12.5	12.5	12.5	12.5	12.5	
		16	16	16	16	16	16	16	16	16	
		20	20	20	20	20	20	20	20	20	
		25 ⁽⁶⁾	25 ⁽⁶⁾	25 ⁽⁶⁾	–	–	–	–	–	–	
Making capacity	Ip [kA]	31.5	31.5	31.5	31.5	31.5	31.5	31.5	31.5	31.5	
		40	40	40	40	40	40	40	40	40	
		50	50	50	50	50	50	50	50	50	
		63	63	63	–	–	–	–	–	–	
Sequence of operations	[O - 0.3s - CO - 15s - CO]	•			•			•			
Opening time	[ms]	40...60			40...60			40...60			
Arcing time	[ms]	10...15			10...15			10...15			
Total break-time	[ms]	50...75			50...75			50...75			
Closing time	[ms]	30...60			30...60			30...60			
Overall dimensions (maximum)		H [mm]	730			730			730		
		L [mm]	282			282			282		
		D [mm]	990			990			990		
		Pole center-distance l [mm]	210			210			210		
Weight ⁽¹⁾	[kg]	67			67			67			
Application of PR521 protection device	In [A]	40 - 80 - 250 - 1250 ⁽²⁾			40 - 80 - 250 - 1250 ⁽²⁾			–			
Application of PR521 protection device ⁽³⁾		see note ⁽³⁾			see note ⁽³⁾			–			
Application of REF 601 protection device ⁽⁴⁾		• ⁽⁴⁾			• ⁽⁴⁾			–			
Standardized dimensions table		1VCD000098			1VCD000098			1VCD000098			
Wiring diagram	without protection device installed	1VCD400098			1VCD400098			1VCD400098			
	with PR521	1VCD400098			1VCD400098			–			
	with PR512	see note ⁽³⁾			see note ⁽³⁾			–			
	with REF 601	1VCD400117			1VCD400117			–			
Operating temperature	[°C]	- 5 ... + 40			- 5 ... + 40			- 5 ... + 40			
Tropicalization	IEC: 60068-2-30, 60721-2-1	•			•			•			
Electromagnetic compatibility	IEC 62271-1	•			•			•			

⁽¹⁾ increase the indicated weight by 20 kg for circuit-breakers with PR521 / PR512 / REF 601 devices and 3 current sensors

⁽²⁾ rated current of the current sensors (the PR521 device and the current sensors are available on request)

⁽³⁾ special version with curves "β = 1" or "β = 1, RI" for the Belgian market: ask ABB for the availability, delivery lead times, wiring diagram

⁽⁴⁾ the rated current of the REF 601 device must be set in the relay in accordance with the circuit-breaker's rated current

⁽⁵⁾ "IEC" or "CEI 0-16" version. If the "CEI 0-16" is required, the circuit-breaker is always supplied with 3 phase current sensors (Rogowsky coils) installed on the actual circuit-breaker and with a loose toroidal TA. In the "CEI 0-16" version, the REF 601 device opens the circuit-breaker by means of the undervoltage release - MU

⁽⁶⁾ rated short-time withstand current 25 kA x 2 s

5.3.4 General specifications of fixed circuit-breakers with rh lateral operating mechanisms for ABB UniMix switchgear (12 - 17.5 - 24 kV)

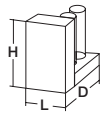
Circuit-breaker		VD4/UniMix 12	VD4/UniMix 17	VD4/UniMix 24	
Standards	IEC 62271-100	•	•	•	
	CEI EN 62271-100 (dossier 7642)	•	•	•	
Rated voltage	Ur [kV]	12	17.5	24	
Rated insulation voltage	Us [kV]	12	17.5	24	
Withstand voltage at 50 Hz	Ud (1 min) [kV]	28	38	50	
Impulse withstand voltage	Up [kV]	75	95	125	
Rated frequency	fr [Hz]	50-60	50-60	50-60	
Rated thermal current (40 °C)	Ir [A]	630	630	630	
Rated duty breaking capacity (symmetrical rated short-circuit current)	Isc [kA]	12.5	12.5	12.5	
		16	16	16	
		20	20	20	
		25	25	–	
Short-time withstand current (3 s)	I _k [kA]	12.5	12.5	12.5	
		16	16	16	
		20	20	20	
		25	25	–	
Making capacity	I _p [kA]	31.5	31.5	31.5	
		40	40	40	
		50	50	50	
		63	63	–	
Sequence of operations	[O - 0.3s - CO - 15s - CO]	•	•	•	
Opening time	[ms]	40...60	40...60	40...60	
Arcing time	[ms]	10...15	10...15	10...15	
Total break-time	[ms]	50...75	50...75	50...75	
Closing time	[ms]	30...60	30...60	30...60	
Overall dimensions (maximum)		H [mm]	700 ⁽¹⁾ / 734 ⁽²⁾	700 ⁽¹⁾ / 734 ⁽²⁾	700 ⁽¹⁾ / 734 ⁽²⁾
		L [mm]	382 (IP30) - 393 (A.I.)	382 (IP30) - 393 (A.I.)	382 (IP30) - 393 (A.I.)
		D [mm]	1030	1030	1030
		Pole center-distance l [mm]	230	230	230
Weight ⁽³⁾	[kg]	65	65	65	
Application of PR521 protection device	I _n [A]	40 - 80 - 250 - 1250 ⁽⁴⁾	40 - 80 - 250 - 1250 ⁽⁴⁾	40 - 80 - 250 - 1250 ⁽⁴⁾	
Application of REF 601 protection device ⁽⁵⁾		• ⁽⁵⁾	• ⁽⁵⁾	• ⁽⁵⁾	
Standardized dimensions table		1VCD000106 ⁽¹⁾	1VCD000106 ⁽¹⁾	1VCD000106 ⁽¹⁾	
		1VCD000107 ⁽²⁾	1VCD000107 ⁽²⁾	1VCD000107 ⁽²⁾	
Wiring diagram	without / with PR521	1VCD400097 ⁽¹⁾	1VCD400097 ⁽¹⁾	1VCD400097 ⁽¹⁾	
		1VCD400098 ⁽²⁾	1VCD400098 ⁽²⁾	1VCD400098 ⁽²⁾	
	with REF 601	1VCD400115 ⁽¹⁾	1VCD400115 ⁽¹⁾	1VCD400115 ⁽¹⁾	
		1VCD400117 ⁽²⁾	1VCD400117 ⁽²⁾	1VCD400117 ⁽²⁾	
Operating temperature	[°C]	- 5 ... + 40	- 5 ... + 40	- 5 ... + 40	
Tropicalization	IEC: 60068-2-30, 60721-2-1	•	•	•	
Electromagnetic compatibility	IEC 62271-1	•	•	•	

⁽¹⁾ VD4/UniMix-F for Unit P1/F (fixed circuit-breaker without wheels and wiring in terminal box)

⁽²⁾ VD4/UniMix-R for Unit P1/F (fixed circuit-breaker without wheels plug connection)

⁽³⁾ increase the indicated weight by 20 kg for circuit-breakers with PR521 / REF 601 devices and 3 current sensors

⁽⁴⁾ rated current of the current sensors (the PR521 device and the current sensors are available on request)

⁽⁵⁾ the rated current of the REF 601 device must be set in the relay in accordance with the circuit-breaker's rated current

⁽⁶⁾ "IEC" or "CEI 0-16" version. If the "CEI 0-16" is required, the circuit-breaker is always supplied with 3 phase current sensors (Rogowsky coils) installed on the actual circuit-breaker and with a loose toroidal TA. In the "CEI 0-16" version, the REF 601 device opens the circuit-breaker by means of the undervoltage release - MU

⁽⁷⁾ for operating temperature -25 °C and storage temperature -40 °C, please ask ABB

5.3.5 General specifications of fixed circuit-breakers with rh lateral operating mechanisms for ABB UniAir IP30 switchgear (12 - 17.5 - 24 kV)

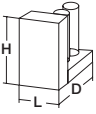
Circuit-breaker		VD4/UniAir 12			VD4/UniAir 17			VD4/UniAir 24			
Standards	IEC 62271-100	●			●			●			
	CEI EN 62271-100 (dossier 7642)	●			●			●			
Rated voltage	Ur [kV]	12			17.5			24			
Rated insulation voltage	Us [kV]	12			17.5			24			
Withstand voltage at 50 Hz	Ud (1 min) [kV]	28			38			50			
Impulse withstand voltage	Up [kV]	75			95			125			
Rated frequency	fr [Hz]	50-60			50-60			50-60			
Rated thermal current (40 °C)	Ir [A]	630	800	1250	630	800	1250	630	800	1250	
Rated duty breaking capacity (symmetrical rated short-circuit current)	Isc [kA]	12.5	–	–	12.5	–	–	12.5	–	–	
		16	16	16	16	16	16	16	16	16	
		20	20	20	20	20	20	20	20	20	
		25	25	25	–	–	–	–	–	–	
Short-time withstand current (3 s)	Ik [kA]	12.5	–	–	–	–	–	12.5	–	–	
		16	16	16	16	16	16	16	16	16	
		20	20	20	20	20	20	20	20	20	
		25	25	25	–	–	–	–	–	–	
Making capacity	Ip [kA]	31.5	–	–	–	–	–	31.5	–	–	
		40	40	40	40	40	40	40	40	40	
		50	50	50	50	50	50	50	50	50	
		63	63	63	–	–	–	–	–	–	
Sequence of operations	[O - 0.3s - CO - 15s - CO]	●			●			●			
Opening time	[ms]	40...60			40...60			40...60			
Arcing time	[ms]	10...15			10...15			10...15			
Total break-time	[ms]	50...75			50...75			50...75			
Closing time	[ms]	30...60			30...60			30...60			
Overall dimensions (maximum)		H [mm]	734,5 ⁽⁴⁾ (5) (6) - 725 ⁽⁷⁾			734,5 ⁽⁴⁾ (5) (6) - 725 ⁽⁷⁾			734,5 ⁽⁴⁾ (5) (6) - 725 ⁽⁷⁾		
		L [mm]	374 ⁽⁴⁾ (5) (6) - 282 ⁽⁷⁾			374 ⁽⁴⁾ (5) (6) - 282 ⁽⁷⁾			374 ⁽⁴⁾ (5) (6) - 282 ⁽⁷⁾		
		D [mm]	1170 ⁽⁴⁾ (5) (6) (7)			1170 ⁽⁴⁾ (5) (6) (7)			1170 ⁽⁴⁾ (5) (6) (7)		
		Pole center-distance l [mm]	300			300			300		
Weight ⁽¹⁾	[kg]	70 ⁽⁴⁾ (5) (6) - 67 ⁽⁷⁾			70 ⁽⁴⁾ (5) (6) - 67 ⁽⁷⁾			70 ⁽⁴⁾ (5) (6) - 67 ⁽⁷⁾			
Application of PR521 protection device	In [A]	40 - 80 - 250 - 1250 ⁽²⁾			40 - 80 - 250 - 1250 ⁽²⁾			40 - 80 - 250 - 1250 ⁽²⁾			
Application of REF 601 protection device ⁽³⁾		● ⁽³⁾			● ⁽³⁾			● ⁽³⁾			
Standardized dimensions table		1VCD000102 ⁽⁴⁾			1VCD000102 ⁽⁴⁾			1VCD000102 ⁽⁴⁾			
		1VCD000103 ⁽⁵⁾			1VCD000103 ⁽⁵⁾			1VCD000103 ⁽⁵⁾			
		1VCD000104 ⁽⁶⁾			1VCD000104 ⁽⁶⁾			1VCD000104 ⁽⁶⁾			
		1VCD000105 ⁽⁷⁾			1VCD000104 ⁽⁷⁾			1VCD000104 ⁽⁷⁾			
Wiring diagram	without / with PR521	1VCD400098 ⁽⁴⁾ (5) (6)			1VCD400098 ⁽⁴⁾ (5) (6)			1VCD400098 ⁽⁴⁾ (5) (6)			
		1VCD400097 ⁽⁷⁾			1VCD400097 ⁽⁷⁾			1VCD400097 ⁽⁷⁾			
	with REF 601	1VCD400117 ⁽⁴⁾ (5) (6)			1VCD400117 ⁽⁴⁾ (5) (6)			1VCD400117 ⁽⁴⁾ (5) (6)			
		1VCD400115 ⁽⁷⁾			1VCD400115 ⁽⁷⁾			1VCD400115 ⁽⁷⁾			
Operating temperature	[°C]	- 5 ... + 40			- 5 ... + 40			- 5 ... + 40			
Tropicalization	IEC: 60068-2-30, 60721-2-1	●			●			●			
Electromagnetic compatibility	IEC 62271-1	●			●			●			

⁽¹⁾ increase the indicated weight by 20 kg for circuit-breakers with PR521 / REF 601 devices and 3 current sensors

⁽²⁾ rated current of the current sensors (the PR521 device and the current sensors are available on request)

⁽³⁾ the rated current of the REF 601 device must be set in the relay in accordance with the circuit-breaker's rated current

⁽⁴⁾ VD4/UniAir for Unit P1/E (unit with plug-in circuit-breaker) version IP30. The circuit-breaker for the similar unit in the Internal Arc version is not available

⁽⁵⁾ VD4/UniAir-2R for Unit P1E/2R (unit with circuit-breaker isolatable on the supply and load sides) version IP30. The circuit-breaker for the similar unit in the Internal Arc version is not available

⁽⁶⁾ VD4/UniAir-A for Unit P1/A (unit with fixed "upside-down" circuit-breaker) version IP30. The circuit-breaker for the similar unit in the Internal Arc version is not available

⁽⁷⁾ VD4/UniAir-F for Unit P1/F (unit with fixed circuit-breaker without wheels and wiring in terminal box) version IP30. The circuit-breaker for the similar unit in the Internal Arc version is not available. Only the following types can be supplied: 12 - 17.5 - 24 kV, 630 A, 12 or 16 kA

⁽⁸⁾ "IEC" or "CEI 0-16" version. If the "CEI 0-16" is required, the circuit-breaker is always supplied with 3 phase current sensors (Rogowsky coils) installed on the actual circuit-breaker and with a loose toroidal TA. In the "CEI 0-16" version, the REF 601 device opens the circuit-breaker by means of the undervoltage release - MU

5.3.6 General specifications of fixed circuit-breakers with rh lateral operating mechanisms for ABB UniSec switchgear (12 - 17.5 - 24 kV)

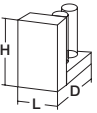
Circuit-breaker		VD4/R-SEC 12			VD4/R-SEC 17			VD4/R-SEC 24			
Standards	IEC 62271-100	●			●			●			
	CEI EN 62271-100 (dossier 7642)	●			●			●			
Rated voltage	Ur [kV]	12			17.5			24			
Rated insulation voltage	Us [kV]	12			17.5			24			
Withstand voltage at 50 Hz	Ud (1 min) [kV]	28 ⁽¹⁾			38 ⁽¹⁾			50			
Impulse withstand voltage	Up [kV]	75			95			125			
Rated frequency	fr [Hz]	50-60			50-60			50-60			
Rated thermal current (40 °C)	Ir [A]	630	800	1250	630	800	1250	630	800	1250	
Rated duty breaking capacity (symmetrical rated short-circuit current)	Isc [kA]	12.5	12.5	-	12.5	12.5	-	12.5	-	-	
		16	16	-	16	16	-	16	-	-	
		20	20	-	20 ⁽²⁾	20 ⁽²⁾	-	20	-	-	
		25	25	-	-	-	-	-	-	-	
Short-time withstand current (3 s)	Ik [kA]	12.5	12.5	-	12.5	12.5	-	12.5	-	-	
		16	16	-	16	16	-	16	-	-	
		20	20	-	20 ⁽²⁾	20 ⁽²⁾	-	20	-	-	
		25 ⁽³⁾	25 ⁽³⁾	-	-	-	-	-	-	-	
Making capacity	Ip [kA]	31.5	31.5	-	31.5	31.5	-	31.5	-	-	
		40	40	-	40	40	-	40	-	-	
		50	50	-	50	50	-	50	-	-	
		63	63	-	-	-	-	-	-	-	
Sequence of operations	[O - 0.3s - CO - 15s - CO]	●			●			●			
Opening time	[ms]	40...60			40...60			40...60			
Arcing time	[ms]	10...15			10...15			10...15			
Total break-time	[ms]	50...75			50...75			50...75			
Closing time	[ms]	30...60			30...60			30...60			
Overall dimensions (maximum)		H [mm]	740			740			740		
		L [mm]	315			315			315		
		D [mm]	1005			1005			1005		
		Pole center-distance I [mm]	230			230			230		
Weight ⁽⁴⁾	[kg]	65			65			65			
Application of PR521 protection device	In [A]	not available			not available			not available			
Application of REF 601 protection device ⁽⁵⁾		● ⁽⁶⁾			● ⁽⁶⁾			● ⁽⁶⁾			
Standardized dimensions table		1VCD000131			1VCD000131			1VCD000131			
Wiring diagram	without / with REF 601	1VCD400118			1VCD400118			1VCD400118			
Operating temperature	[°C]	-5 ... +40 ⁽⁷⁾			-5 ... +40 ⁽⁷⁾			-5 ... +40 ⁽⁷⁾			
Tropicalization	IEC: 60068-2-30, 60721-2-1	●			●			●			
Electromagnetic compatibility	IEC 62271-1	●			●			●			

⁽¹⁾ for 12.08.20 and 17.08.20, versions with withstand voltage up to 42 kV are available

⁽²⁾ rated duty breaking capacity 21 kA at 17.5 kV. Rated short-time withstand current 21 kA x 3 s

⁽³⁾ rated short-time withstand current 25 kA x 2 s

⁽⁴⁾ increase the indicated weight by 20 kg for circuit-breakers with REF 601 devices and 3 current sensors

⁽⁵⁾ "IEC" or "CEI 0-16" version. If the "CEI 0-16" is required, the circuit-breaker is always supplied with 3 phase current sensors (Rogowsky coils) installed on the actual circuit-breaker and with a loose toroidal TA. In the "CEI 0-16" version, the REF 601 device opens the circuit-breaker by means of the undervoltage release -MU

⁽⁶⁾ the rated current of the REF 601 device must be set in the relay in accordance with the circuit-breaker's rated current

⁽⁷⁾ for 12.08.20 and 17.08.20, versions with operating temperature up to -25 °C and storage temperature up to -40 °C are available

5.3.7 General specifications of fixed circuit-breakers with Ih lateral operating mechanisms for ABB UniSec switchgear (12 - 17.5 - 24 kV)

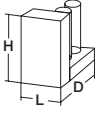
Circuit-breaker		VD4/L-SEC 12			VD4/L-SEC 17			VD4/L-SEC 24			
Standards	IEC 62271-100	•			•			•			
	CEI EN 62271-100 (dossier 7642)	•			•			•			
Rated voltage	Ur [kV]	12			17.5			24			
Rated insulation voltage	Us [kV]	12			17.5			24			
Withstand voltage at 50 Hz	Ud (1 min) [kV]	28 ⁽¹⁾			38 ⁽¹⁾			50			
Impulse withstand voltage	Up [kV]	75			95			125			
Rated frequency	fr [Hz]	50-60			50-60			50-60			
Rated thermal current (40 °C)	Ir [A]	630	800	1250	630	800	1250	630	800	1250	
Rated duty breaking capacity (symmetrical rated short-circuit current)	Isc [kA]	12.5	12.5	–	12.5	12.5	–	12.5	–	–	
		16	16	–	16	16	–	16	–	–	
		20	20	–	20 ⁽²⁾	20 ⁽²⁾	–	20	–	–	
		25	25	–	–	–	–	–	–	–	
Short-time withstand current (3 s)	Ik [kA]	12.5	12.5	–	12.5	12.5	–	12.5	–	–	
		16	16	–	16	16	–	16	–	–	
		20	20	–	20 ⁽²⁾	20 ⁽²⁾	–	20	–	–	
		25 ⁽³⁾	25 ⁽³⁾	–	–	–	–	–	–	–	
Making capacity	Ip [kA]	31.5	31.5	–	31.5	31.5	–	31.5	–	–	
		40	40	–	40	40	–	40	–	–	
		50	50	–	50	50	–	50	–	–	
		63	63	–	–	–	–	–	–	–	
Sequence of operations	[O - 0.3s - CO - 15s - CO]	•			•			•			
Opening time	[ms]	40...60			40...60			40...60			
Arcing time	[ms]	10...15			10...15			10...15			
Total break-time	[ms]	50...75			50...75			50...75			
Closing time	[ms]	30...60			30...60			30...60			
Overall dimensions (maximum)		H [mm]	740			740			740		
		L [mm]	315			315			315		
		D [mm]	1005			1005			1005		
		Pole center-distance l [mm]	230			230			230		
Weight ⁽⁴⁾	[kg]	65			65			65			
Application of PR521 protection device	In [A]	not available			not available			not available			
Application of REF 601 protection device ⁽⁵⁾		• ⁽⁶⁾			• ⁽⁶⁾			• ⁽⁶⁾			
Standardized dimensions table		1VCD000132			1VCD000132			1VCD000132			
Wiring diagram	without / with REF 601	1VCD400118			1VCD400118			1VCD400118			
Operating temperature	[°C]	-5 ... +40 ⁽⁷⁾			-5 ... +40 ⁽⁷⁾			-5 ... +40 ⁽⁷⁾			
Tropicalization	IEC: 60068-2-30, 60721-2-1	•			•			•			
Electromagnetic compatibility	IEC 62271-1	•			•			•			

⁽¹⁾ for 12.08.20 and 17.08.20, versions with withstand voltage up to 42 kV are available

⁽²⁾ rated duty breaking capacity 21 kA at 17.5 kV. Rated short-time withstand current 21 kA x 3 s

⁽³⁾ rated short-time withstand current 25 kA x 2 s

⁽⁴⁾ increase the indicated weight by 20 kg for circuit-breakers with REF 601 devices and 3 current sensors

⁽⁵⁾ "IEC" or "CEI 0-16" version. If the "CEI 0-16" is required, the circuit-breaker is always supplied with 3 phase current sensors (Rogowsky coils) installed on the actual circuit-breaker and with a loose toroidal TA. In the "CEI 0-16" version, the REF 601 device opens the circuit-breaker by means of the undervoltage release -MU

⁽⁶⁾ the rated current of the REF 601 device must be set in the relay in accordance with the circuit-breaker's rated current

⁽⁷⁾ for 12.08.20 and 17.08.20, versions with operating temperature up to -25 °C and storage temperature up to -40 °C are available

5.4 Standard equipment

5.4.1 VD4/R fixed circuit-breakers with rh lateral operating mechanisms (230 or 300 mm distance between centers) and VD4/L fixed circuit-breakers with lh lateral operating mechanisms (230 or 300 mm distance between centers)

The coded basic version of the fixed circuit-breakers is always the three-pole type and comes equipped with:

- 1 opening pushbutton
- 2 closing pushbutton
- 3 operation counter
- 4 circuit-breaker open/closed indicator
- 5 lever for loading the springs in the manual mode (built into the operating mechanism)
- 6 indicator for closing springs loaded/relieved.

The basic wiring ends in the terminal box. This latter is equipped with a withdrawable part that allows the customer to create a disconnectable connection (see pictures).



Figure 4

The basic version also includes the following accessories to be specified at the time of ordering:

Kit 1 set of five opened/closed auxiliary contacts or alternatively, with a surcharge, ten or fifteen auxiliary contacts. Each shunt opening device uses an NO auxiliary contact to shut off its power supply after the circuit-breaker has been opened. This means that there is one NO auxiliary contact less for every opening release installed.

Kit 2 opening release

Kit 3 key lock.

5.4.2 Circuit-breakers for UniSwitch switchgear with rh lateral operating mechanisms (210 mm distance between centers)

The coded basic version of **VD4/S** circuit-breakers for UniSwitch switchgear is the same as that of the fixed circuit-breakers, with the following specific exceptions and equipment:

- base with wheels to make the UniSwitch switchgear easier to move and rack-in to the compartment
- upper and lower terminals pre-engineered for connection to the busbars of the UniSwitch switchgear
- insulating caps to install in the upper part of the poles (after the busbars have been connected to the upper terminals)
- a dedicated connector (58-pole bayonet connection plug) fixed to the right-hand side of the operating mechanism's dustproof enclosure. The connector has a lock that inhibits manual operation unless the relative plug with insulating release pin is inserted
- insulating release pin to insert into the plug (female with 58 poles) and disable the lock that inhibits manual operation unless the plug is plugged into the socket on the operating mechanism.

A set of 12 auxiliary contacts is available on request, with a surcharge, as an alternative to the opened/closed group of 5 auxiliary contacts. Each shunt opening device uses an NO auxiliary contact to shut off its power supply after the circuit-breaker has been opened. This means that there is an unavailable NO auxiliary contact for every opening release installed.



Figure 5a

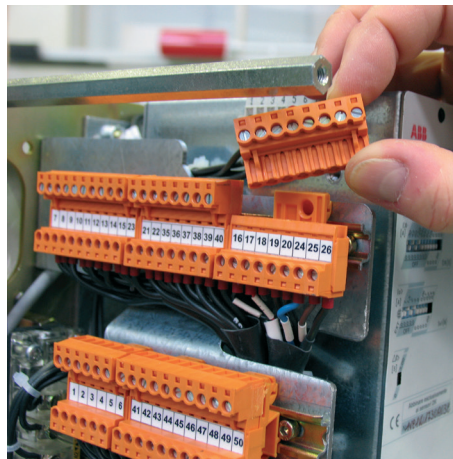

Figure 5b



Figure 5c

5.4.3 Circuit-breakers for UniMix switchgear with rh lateral operating mechanisms (230 mm distance between centers)

The coded basic version of the circuit-breakers for UniMix switchgear is the same as that of the fixed circuit-breakers. The operating mechanism's dustproof enclosure is equipped with a specific side frame for the UniMix unit into which the circuit-breaker must be inserted. In detail:

- the upper and lower terminals of the **VD4/UniMix-F** type are pre-engineered for connection to the busbars of the P1/F unit UniMix switchgear. 10 or 15 auxiliary contacts are available as an alternative, with a surcharge. Each opening release uses an NO auxiliary contact to shut off its power supply after the circuit-breaker has been opened. This means that there is an unavailable NO auxiliary contact for every opening release installed
- the **VD4/UniMix-R** type has a base with wheels to make the switchgear easier to move and rack-in to the compartment, a connection with 58-pole plug for the auxiliary circuits and upper and lower terminals pre-engineered for connection to the busbars of the P1/F unit UniMix switchgear. 12 auxiliary contacts are available as an alternative, with a surcharge. Each opening release uses an NO auxiliary contact to shut off its power supply after the circuit-breaker has been opened. This means that there is an unavailable NO auxiliary contact for every opening release installed.

5.4.4 Circuit-breakers for UniAir switchgear with rh lateral operating mechanisms (300 mm distance between centers)

The coded basic version of the circuit-breakers for UniAir switchgear is the same as that of the fixed circuit-breakers. The operating mechanism's dustproof enclosure is equipped with a specific side frame for the UniAir unit into which the circuit-breaker must be inserted. In detail:

- the **VD4/UniAir** type has a base with wheels to make the switchboard easier to move and rack-in to the compartment, a connection with 58-pole plug for the auxiliary circuits, upper and lower terminals pre-engineered with jaw contact for connection to the isolator on the supply side and to the busbars (or TA DIN) on the load side of the P1/E unit UniAir switchgear, and the release lever that keeps the circuit-breaker locked in the cubicle. 12 auxiliary contacts are available as an alternative, with a surcharge. Each opening release uses an NO auxiliary contact to shut off its power supply after the circuit-breaker has been opened. This means that there is an unavailable NO auxiliary contact for every opening release installed
- the **VD4/UniAir-2R** type has a base with wheels to make the switchgear easier to move and rack-in to the compartment, a connection with 58-pole plug for the auxiliary circuits, upper and lower terminals pre-engineered with jaw contact for connection to the isolator on the supply side and on the load side to the busbars of the P1E/2R unit UniAir switchgear, and the release lever that keeps the circuit-breaker locked in the cubicle. 12 auxiliary contacts are available as an alternative, with a surcharge. Each opening release uses an NO auxiliary contact to shut off its power supply after the circuit-breaker has been opened. This means that there is an unavailable NO auxiliary contact for every opening release installed

- the **VD4/UniAir-A** type has a base with wheels to make the switchgear easier to move and rack-in to the compartment, a connection with 58-pole plug for the auxiliary circuits, fixed upper terminals and lower terminals pre-engineered with jaw contact for connection to the busbars/TA on the supply side and on the load side to the isolator of the P1/A unit UniAir switchgear, and the release lever that keeps the circuit-breaker locked in the cubicle. 12 auxiliary contacts are available as an alternative, with a surcharge. Each opening release uses an NO auxiliary contact to shut off its power supply after the circuit-breaker has been opened. This means that there is an unavailable NO auxiliary contact for every opening release installed
- the **VD4/UniAir-F** type is equipped with wheels and loose connection while only the upper terminals are pre-engineered with jaw contacts for connection to the isolator on the supply side while the fixed lower terminals are pre-engineered for connection to the busbars/TA on the supply side of the P1/F unit UniAir switchgear. 10 or 15 auxiliary contacts are available. Each opening release uses an NO auxiliary contact to shut off its power supply after the circuit-breaker has been opened. This means that there is an unavailable NO auxiliary contact for every opening release installed.

5.4.5 Circuit-breakers for UniSec switchgear with rh or lh lateral operating mechanisms (230 mm distance between centers)

The coded basic version of the circuit-breakers for UniSec switchgear is the same as that of the fixed circuit-breakers, with the following specific exceptions and equipment:

- the dustproof enclosure of the operating mechanism is equipped with a specific side frame for the UniSec switchgear
- the base is equipped with wheels to make the switchgear easier to move and rack-in to the compartment
- the wiring ends at the terminal box equipped with a withdrawable part and can be accessed without removing the operating mechanism's dustproof enclosure. The terminal box is actually situated at the front and projects over the upper edge of the enclosure
- the front enclosure has a transparent sliding shutter over the mechanical indicators, the operating pushbuttons and the hand lever that loads the closing spring. This protection prevents hot gas from escaping if an arc forms in the UniSec circuit-breaker compartment. On request, this shutter can be equipped with a padlock to prevent it from sliding and thus inhibit the opening and closing buttons from being used
- 10 auxiliary contacts are available on request, with a surcharge, as an alternative. Since each shunt opening device uses an NO auxiliary contact to shut off its power supply after having opened the circuit-breaker, there is an unavailable NO auxiliary contact for every opening release installed
- on request, this version can be supplied with just the REF 601 protection device. The PR 521 protection device cannot be supplied for the VD4 version for UniSec.

5.5 Available types

5.5.1 VD4/R 12-17-24 rh lateral operating mechanism

U [kV]	In [A]	Isc [kA]	Description	Pole center distance		Wiring diagram	
				230 mm	300 mm		
				1VCD000100	1VCD000101		
12	630	12.5	VD4/R 12.06.12	•	•		
		16	VD4/R 12.06.16	•	•		
		20	VD4/R 12.06.20	•	•		
		25	VD4/R 12.06.25	•	•		
	800	16	VD4/R 12.08.16	•	•		
		20	VD4/R 12.08.20	•	•		
		25	VD4/R 12.08.25	•	•		
	1250	16	VD4/R 12.12.16	•	•		without relay 1VCD400097
		20	VD4/R 12.12.20	•	•		
		25	VD4/R 12.12.25	•	•		
17.5	630	12.5	VD4/R 17.06.12	•	•	with relay PR 521 1VCD400097	
		16	VD4/R 17.06.16	•	•		
		20	VD4/R 17.06.20	•	•		
		25	VD4/R 17.06.25	•	•		
	800	16	VD4/R 17.08.16	•	•		
		20	VD4/R 17.08.20	•	•		
		25	VD4/R 17.08.25	•	•		
	1250	16	VD4/R 17.12.16	•	•		with relay REF601 1VCD400115
		20	VD4/R 17.12.20	•	•		
		25	VD4/R 17.12.25	•	•		
24	630	12.5	VD4/R 24.06.12	•	•		
		16	VD4/R 24.06.16	•	•		
		20	VD4/R 24.06.20	•	•		
	800	16	VD4/R 24.08.16	•	•		
		20	VD4/R 24.08.20	•	•		
	1250	16	VD4/R 24.12.16	•	•		
		20	VD4/R 24.12.20	•	•		

5.5.2 VD4/L 12-17-24 lh lateral operating mechanism

U [kV]	In [A]	Isc [kA]	Description	Pole center distance		Wiring diagram	
				230 mm	300 mm		
				1VCD003453	1VCD003454		
12	630	12.5	VD4/L 12.06.12	•	•		
		16	VD4/L 12.06.16	•	•		
		20	VD4/L 12.06.20	•	•		
		25	VD4/L 12.06.25	•	•		
	800	16	VD4/L 12.08.16	•	•		
		20	VD4/L 12.08.20	•	•		
		25	VD4/L 12.08.25	•	•		
	1250	16	VD4/L 12.12.16	•	•		without relay 1VCD400097
		20	VD4/L 12.12.20	•	•		
		25	VD4/L 12.12.25	•	•		
17.5	630	12.5	VD4/L 17.06.12	•	•	with relay PR 521 1VCD400097	
		16	VD4/L 17.06.16	•	•		
		20	VD4/L 17.06.20	•	•		
		25	VD4/L 17.06.25	•	•		
	800	16	VD4/L 17.08.16	•	•		
		20	VD4/L 17.08.20	•	•		
		25	VD4/L 17.08.25	•	•		
	1250	16	VD4/L 17.12.16	•	•		with relay REF601 1VCD400115
		20	VD4/L 17.12.20	•	•		
		25	VD4/L 17.12.25	•	•		
24	630	12.5	VD4/L 24.06.12	•	•		
		16	VD4/L 24.06.16	•	•		
		20	VD4/L 24.06.20	•	•		
	800	16	VD4/L 24.08.16	•	•		
		20	VD4/L 24.08.20	•	•		
	1250	16	VD4/L 24.12.16	•	•		
		20	VD4/L 24.12.20	•	•		

5.5.3 VD4/S 12-17-24 rh lateral operating mechanism, version for UniSwitch switchgear

U [kV]	In [A]	Isc [kA]	Description	Pole center distance	Wiring diagram		
				210 mm 1VCD000098			
12	630	12.5	VD4/S 12.06.12	•	without relay 1VCD400098		
		16	VD4/S 12.06.16	•			
		20	VD4/S 12.06.20	•			
		25	VD4/S 12.06.25	•			
	800	12.5	VD4/S 12.08.12	•			
		16	VD4/S 12.08.16	•			
		20	VD4/S 12.08.20	•			
		25	VD4/S 12.08.25	•			
	1250	12.5	VD4/S 12.12.12	•			
		16	VD4/S 12.12.16	•			
		20	VD4/S 12.12.20	•			
		25	VD4/S 12.12.25	•			
17.5	630	12.5	VD4/S 17.06.12	•	with relay PR 521 1VCD400098		
		16	VD4/S 17.06.16	•			
		20	VD4/S 17.06.20	•			
	800	12.5	VD4/S 17.08.12	•			
		16	VD4/S 17.08.16	•			
		20	VD4/S 17.08.20	•			
	1250	12.5	VD4/S 17.12.12	•		with relay REF601 1VCD400117	
		16	VD4/S 17.12.16	•			
		20	VD4/S 17.12.20	•			
	24	630	12.5	VD4/S 24.06.12		•	
			16	VD4/S 24.06.16		•	
			20	VD4/S 24.06.20		•	
800		12.5	VD4/S 24.08.12	•			
		16	VD4/S 24.08.16	•			
		20	VD4/S 24.08.20	•			
1250		12.5	VD4/S 24.12.12	•			
		16	VD4/S 24.12.16	•			
		20	VD4/S 24.12.20	•			

5.5.4 VD4/UniMix-F 12-17-24 rh lateral operating mechanism, version for UniMix switchgear unit P1/F (IP30/Internal arc) circuit-breaker without wheels, wired to terminal box

U [kV]	In [A]	Isc [kA]	Description	Pole center distance	Wiring diagram
				210 mm 1VCD000106	
12	630	12.5	VD4/UniMix-F 12.06.12	•	without relay 1VCD400097
		16	VD4/UniMix-F 12.06.16	•	
		20	VD4/UniMix-F 12.06.20	•	
		25	VD4/UniMix-F 12.06.25	•	
17.5	630	12.5	VD4/UniMix-F 17.06.12	•	with relay PR 521 1VCD400097
		16	VD4/UniMix-F 17.06.16	•	
		20	VD4/UniMix-F 17.06.20	•	
		25	VD4/UniMix-F 17.06.25	•	
24	630	12.5	VD4/UniMix-F 24.06.12	•	with relay REF601 1VCD400115
		16	VD4/UniMix-F 24.06.16	•	
		20	VD4/UniMix-F 24.06.20	•	

5.5.5 VD4/UniMix-R 12-17-24 rh lateral operating mechanism, version for UniMix switchgear unit P1/F (IP30/Internal arc) circuit-breaker with wheels, equipped with loose connection with 64-pin plug

U [kV]	In [A]	Isc [kA]	Description	Pole center distance	Wiring diagram
				210 mm 1VCD000107	
12	630	12.5	VD4/UniMix-R 12.06.12	•	without relay 1VCD400098
		16	VD4/UniMix-R 12.06.16	•	
		20	VD4/UniMix-R 12.06.20	•	
		25	VD4/UniMix-R 12.06.25	•	
17.5	630	12.5	VD4/UniMix-R 17.06.12	•	with relay PR 521 1VCD400098
		16	VD4/UniMix-R 17.06.16	•	
		20	VD4/UniMix-R 17.06.20	•	
		25	VD4/UniMix-R 17.06.25	•	
24	630	12.5	VD4/UniMix-R 24.06.12	•	with relay REF601 1VCD400117
		16	VD4/UniMix-R 24.06.16	•	
		20	VD4/UniMix-R 24.06.20	•	

5.5.6 VD4/UniAir 12-17-24 rh lateral operating mechanism, version for UniAir switchgear unit P1/E (IP30 version) unit with circuit-breaker isolatable on the supply side

U [kV]	In [A]	Isc [kA]	Description	Pole center distance	Wiring diagram
				300 mm 1VCD000102	
12	630	12.5	VD4/UniAir 12.06.12	•	without relay 1VCD400098
		16	VD4/UniAir 12.06.16	•	
		20	VD4/UniAir 12.06.20	•	
		25	VD4/UniAir 12.06.25	•	
	800	16	VD4/UniAir 12.08.16	•	
		20	VD4/UniAir 12.08.20	•	
		25	VD4/UniAir 12.08.25	•	
	1250	16	VD4/UniAir 12.12.16	•	
		20	VD4/UniAir 12.12.20	•	
25		VD4/UniAir 12.12.25	•		
17.5	630	12.5	VD4/UniAir 17.06.12	•	with relay PR 521 1VCD400098
		16	VD4/UniAir 17.06.16	•	
		20	VD4/UniAir 17.06.20	•	
	800	16	VD4/UniAir 17.08.16	•	
		20	VD4/UniAir 17.08.20	•	
	1250	16	VD4/UniAir 17.12.16	•	
20	16	VD4/UniAir 17.12.20	•		
	25	VD4/UniAir 17.12.25	•		
24	630	12.5	VD4/UniAir 24.06.12	•	with relay REF601 1VCD400117
		16	VD4/UniAir 24.06.16	•	
		20	VD4/UniAir 24.06.20	•	
	800	16	VD4/UniAir 24.08.16	•	
		20	VD4/UniAir 24.08.20	•	
	1250	16	VD4/UniAir 24.12.16	•	
		20	VD4/UniAir 24.12.20	•	
		25	VD4/UniAir 24.12.25	•	

5.5.7 VD4/UniAir-2R 12-17-24 rh lateral operating mechanism, version for UniAir switchgear unit P1E/2R (IP30 version) unit with circuit-breaker isolatable on the supply and load sides

U [kV]	In [A]	Isc [kA]	Description	Pole center distance	Wiring diagram	
				300 mm 1VCD000103		
12	630	12.5	VD4/UniAir-2R 12.06.12	•	without relay 1VCD400098	
		16	VD4/UniAir-2R 12.06.16	•		
		20	VD4/UniAir-2R 12.06.20	•		
		25	VD4/UniAir-2R 12.06.25	•		
	800	16	VD4/UniAir-2R 12.08.16	•		
		20	VD4/UniAir-2R 12.08.20	•		
		25	VD4/UniAir-2R 12.08.25	•		
	1250	16	VD4/UniAir-2R 12.12.16	•		
		20	VD4/UniAir-2R 12.12.20	•		
25		VD4/UniAir-2R 12.12.25	•			
17.5	630	12.5	VD4/UniAir-2R 17.06.12	•	with relay PR 521 1VCD400098	
		16	VD4/UniAir-2R 17.06.16	•		
		20	VD4/UniAir-2R 17.06.20	•		
	800	16	VD4/UniAir-2R 17.08.16	•		
		20	VD4/UniAir-2R 17.08.20	•		
	1250	16	VD4/UniAir-2R 17.12.16	•	with relay REF601 1VCD400117	
		20	VD4/UniAir-2R 17.12.20	•		
	24	630	12.5	VD4/UniAir-2R 24.06.12	•	with relay REF601 1VCD400117
			16	VD4/UniAir-2R 24.06.16	•	
20			VD4/UniAir-2R 24.06.20	•		
800		16	VD4/UniAir-2R 24.08.16	•		
		20	VD4/UniAir-2R 24.08.20	•		
1250		16	VD4/UniAir-2R 24.12.16	•		
		20	VD4/UniAir-2R 24.12.20	•		

5.5.8 VD4/UniAir-A 12-17-24 rh lateral operating mechanism, version for UniAir switchgear unit P1/A (IP30 version) “upside-down” unit with circuit-breaker isolatable on the load side

U [kV]	In [A]	Isc [kA]	Description	Pole center distance	Wiring diagram	
				300 mm 1VCD000104		
12	630	12.5	VD4/UniAir-A 12.06.12	•	without relay 1VCD400098	
		16	VD4/UniAir-A 12.06.16	•		
		20	VD4/UniAir-A 12.06.20	•		
		25	VD4/UniAir-A 12.06.25	•		
	800	16	VD4/UniAir-A 12.08.16	•		
		20	VD4/UniAir-A 12.08.20	•		
		25	VD4/UniAir-A 12.08.25	•		
	1250	16	VD4/UniAir-A 12.12.16	•		
		20	VD4/UniAir-A 12.12.20	•		
25		VD4/UniAir-A 12.12.25	•			
17.5	630	12.5	VD4/UniAir-A 17.06.12	•	with relay PR 521 1VCD400098	
		16	VD4/UniAir-A 17.06.16	•		
		20	VD4/UniAir-A 17.06.20	•		
	800	16	VD4/UniAir-A 17.08.16	•		
		20	VD4/UniAir-A 17.08.20	•		
	1250	16	VD4/UniAir-A 17.12.16	•	with relay REF601 1VCD400117	
		20	VD4/UniAir-A 17.12.20	•		
	24	630	12.5	VD4/UniAir-A 24.06.12	•	with relay REF601 1VCD400117
			16	VD4/UniAir-A 24.06.16	•	
20			VD4/UniAir-A 24.06.20	•		
800		16	VD4/UniAir-A 24.08.16	•		
		20	VD4/UniAir-A 24.08.20	•		
1250		16	VD4/UniAir-A 24.12.16	•		
		20	VD4/UniAir-A 24.12.20	•		

5.5.9 VD4/UniAir-F 12-17-24 rh lateral operating mechanism, version for UniAir switchgear, unit P1/F (IP30 version) unit with fixed circuit-breaker without wheels, wired to terminal box

U [kV]	In [A]	Isc [kA]	Description	Pole center distance	Wiring diagram
				300 mm 1VCD000105	
12	630	12.5	VD4/UniAir-F 12.06.12	•	without relay 1VCD400097
		16	VD4/UniAir-F 12.06.16	•	
17.5	630	12.5	VD4/UniAir-F 17.06.12	•	with relay PR 521 1VCD400097
		16	VD4/UniAir-F 17.06.16	•	
24	630	12.5	VD4/UniAir-F 24.06.12	•	with relay REF601 1VCD400115
		16	VD4/UniAir-F 24.06.16	•	

5.5.10 VD4/R-SEC 12-17-24 rh lateral operating mechanism, version for UniSec switchgear

U [kV]	In [A]	Isc [kA]	Description	Pole center distance	Wiring diagram ⁽¹⁾
				230 mm 1VCD000131	
12	630	12.5	VD4/R-SEC 12.06.12	•	without relay 1VCD400118
		16	VD4/R-SEC 12.06.16	•	
		20	VD4/R-SEC 12.06.20	•	
		25	VD4/R-SEC 12.06.25	•	
	800	12.5	VD4/R-SEC 12.08.12	•	
		16	VD4/R-SEC 12.08.16	•	
		20	VD4/R-SEC 12.08.20	•	
		25	VD4/R-SEC 12.08.25	•	
17.5	630	12.5	VD4/R-SEC 17.06.12	•	with relay REF601 1VCD400118
		16	VD4/R-SEC 17.06.16	•	
		20	VD4/R-SEC 17.06.20	•	
	800	12.5	VD4/R-SEC 17.08.12	•	
		16	VD4/R-SEC 17.08.16	•	
		20	VD4/R-SEC 17.08.20	•	
24	630	12.5	VD4/R-SEC 24.06.12	•	
		16	VD4/R-SEC 24.06.16	•	
		20	VD4/R-SEC 24.06.20	•	

⁽¹⁾ this version is not available with relay PR 521

5.5.11 VD4/L-SEC 12-17-24 lh lateral operating mechanism, version for UniSec switchgear

U [kV]	In [A]	Isc [kA]	Description	Pole center distance	Wiring diagram ⁽¹⁾
				230 mm 1VCD000132	
12	630	12.5	VD4/L-SEC 12.06.12	•	without relay 1VCD400118
		16	VD4/L-SEC 12.06.16	•	
		20	VD4/L-SEC 12.06.20	•	
		25	VD4/L-SEC 12.06.25	•	
	800	12.5	VD4/L-SEC 12.08.12	•	
		16	VD4/L-SEC 12.08.16	•	
		20	VD4/L-SEC 12.08.20	•	
		25	VD4/L-SEC 12.08.25	•	
17.5	630	12.5	VD4/L-SEC 17.06.12	•	with relay REF601 1VCD400118
		16	VD4/L-SEC 17.06.16	•	
		20	VD4/L-SEC 17.06.20	•	
	800	12.5	VD4/L-SEC 17.08.12	•	
		16	VD4/L-SEC 17.08.16	•	
		20	VD4/L-SEC 17.08.20	•	
24	630	12.5	VD4/L-SEC 24.06.12	•	
		16	VD4/L-SEC 24.06.16	•	
		20	VD4/L-SEC 24.06.20	•	

⁽¹⁾ this version is not available with relay PR 521

5.6 Characteristics of the electrical accessories

Shunt opening release (-M01); Additional shunt opening release (-M02); Shunt closing release (-MC)

Un	LV: 24...30 Vcc; 48...60 Vcc/ac 50-60 Hz
Un	HV: 110...132 - 220...250 Vcc/ac 50-60 Hz
Operating limits	65...120% Un
Power on inrush (Ps)	70 W
Inrush time	150 ms
Holding power (Pc)	1.5 W
Opening time	40...60 ms
Closing time	30...60 ms
Insulation voltage	2000 V 50 Hz (for 1 min)

Undervoltage release (-MU)

Un	LV: 24...30 Vcc; 48...60 Vcc/ac 50-60 Hz
Un	HV: 110...132 - 220...250 Vcc/ac 50-60 Hz
Operating limits:	
– circuit-breaker opening	35-70% Un
– circuit-breaker closing	85-110% Un
Power on inrush (Ps)	150 W
Inrush time	150 ms
Holding power (Pc)	3 W
Opening time	60...80 ms
Insulation voltage	2000 V 50 Hz (for 1 min)

Electronic time delay device for undervoltage release (installed outside the circuit-breaker)

Un	24...30 - 48 - 60 - 110...127 - 220...250 V-
Un	48 - 60 - 110...127 - 220...240 V~ 50/60 Hz
Adjustable opening time (release + time-lag device)	0.5 - 1 - 1.5 - 2 - 3 s

Auxiliary contacts of the circuit-breaker

Un	24 ... 250 V AC-DC
Rated current	I _{th2} = 10 A
Insulation voltage	2000 V 50 Hz (for 1 min)
Electrical resistance	3 mOhm

Rated current and breaking capacity in class AC11 and DC11

Un	Cosφ	T	I _n	I _{cu}
220 V~	0.7	–	2.5 A	25 A
24 V-	–	15 ms	10 A	12 A
60 V-	–	15 ms	6 A	8 A
110 V-	–	15 ms	4 A	5 A
220 V-	–	15 ms	1 A	2 A

Motor operator (-MS)

Specifications	
Un	24...30 - 48...60 - 110...130 - 220...250 V-
Un	100...130 - 220...250 V ~ 50/60 Hz
Operating limits	85...110 % Un
Power on inrush (Ps)	DC=600 W; AC=600 VA
Rated power (Pn)	DC=200 W; AC=200 VA
Inrush time	0.2 s
Loading time	6-7 s
Insulation voltage	2000 V 50 Hz (for 1 min)

Summary of the total quantity of auxiliary contacts available^(*)

Total quantity	5 auxiliary contacts (-BB1)	10 auxiliary contacts (-BB1, -BB2)	12 auxiliary contacts (-BB1, -BB2, -BB3)	15 auxiliary contacts (-BB1, -BB2, -BB3)
VD4/R p230 VD4/R p300 VD4/L p230 VD4/L p300	Standard equipment	Alternative available on request. This is the obligatory minimum quantity if -M02 (the additional opening release) is also required	Alternative not available	Alternative available on request
VD4/UniMix-F p230	Standard equipment	As above	As above	As above
VD4/UniAir-F p230	Standard equipment	As above	As above	As above
VD4/S p210	Standard equipment	Alternative not available	Alternative available on request. This is the obligatory minimum quantity if -M02 (the additional opening release) is also required	Alternative not available
VD4/UniMix-R p230	Standard equipment	Alternative not available	As above	As above
VD4/UniAir VD4/UniAir-2R VD4/UniAir-A p300	Standard equipment	Alternative not available	As above	As above
VD4/R-SEC VD4/L-SEC	Standard equipment	Alternative available on request but with 8 auxiliary contacts	Alternative not available	As above

^(*) Each opening release required uses an auxiliary contact to shut off its power supply after having opened the circuit-breaker. Thus the number of auxiliary contacts really available diminishes in the same way as the number of opening releases installed.

6. Instructions for circuit-breaker operation

6.1 Safety indications



VD4 circuit-breakers guarantee a minimum IP3X degree of protection when installed in the following conditions:

- fixed circuit-breaker, installed behind a protective metal net
- plug-in circuit-breaker, installed in switchgear.

In these conditions the operator is totally protected against accidental contact with moving parts.

Pay the greatest attention to moving parts if the circuit-breaker is subjected to mechanical operations outside the switchgear.

If the operations are obstructed, do not force the mechanical interlocks and check that the operating sequence is correct.

The circuit-breaker must be gradually racked-in and out of the switchgear to avoid shocks that could deform the mechanical interlocks.

6.2 Operating and signalling parts

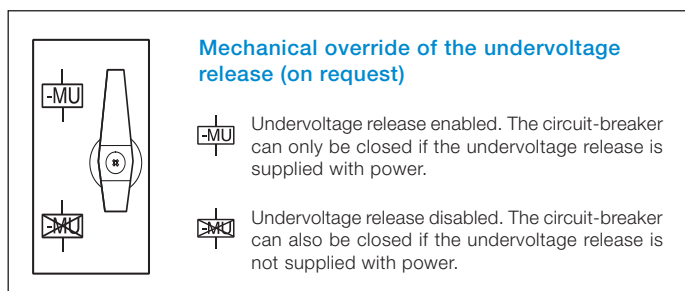
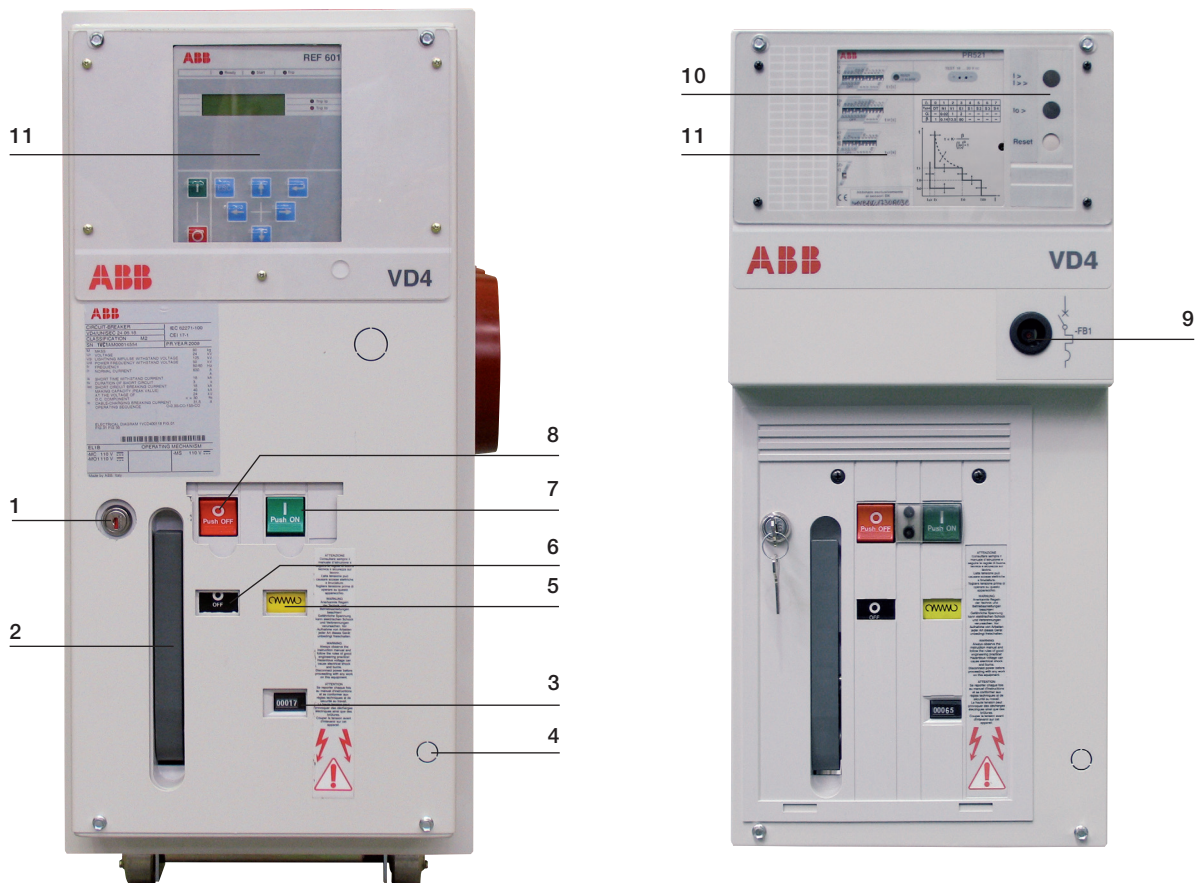

Key

- 1 Key lock
- 2 Closing spring loading lever
- 3 Operation counter
- 4 Housing of the undervoltage release's mechanical override
- 5 Indicator for closing springs loaded/relieved
- 6 Circuit-breaker open/closed indicator
- 7 Closing pushbutton
- 8 Opening pushbutton
- 9 Gearmotor protection circuit-breaker reset pushbutton
- 10 Relay trip indicator
- 11 Relay REF601/PR521

Figura 6

6.3 Circuit-breaker closing and opening operations

Circuit-breaker operation can be either manual or electrical.

a) Manual loading of the closing springs (fig. 6)

Repeatedly operate the loading lever (2) (the lever's maximum angle of rotation is about 90°) until the yellow indicator appears (5).

Maximum force that can normally be applied to the lever: ≤150 N.

b) Electrical loading of the closing springs

On request, the circuit-breaker can be fitted with the following accessories for electrical operation:

- gearmotor for automatic loading of the closing springs
- shunt closing release.

When powered, the gearmotor automatically reloads the springs after every closing operation until the yellow indicator appears (7).

If there is a power failure during the loading operation, the gearmotor stops and automatically continues with the spring loading operation once the power returns.

However, it is always possible to complete the loading operation in the manual mode.

To avoid excessive power consumption in installations with several circuit-breakers and a motor operator, it is advisable to load one operating mechanism at a time during the starting stage.

c) Circuit-breaker closing

This operation can only be carried out when the closing springs are fully loaded.

Press the pushbutton (7 - fig. 6) to close the circuit-breaker in the manual mode.

When there is a shunt closing release, the operation can also be carried out in the remote mode by means of the special control circuit. The closed status is signalled by the indicator (6 - fig. 6).

The closing pushbutton is not accessible in VD4/UniAir plug-in circuit-breakers without PR521 release.

d) Circuit-breaker opening

Press the pushbutton (8 - fig. 6) to open the circuit-breaker in the manual mode.

When there is a shunt opening release, the operation can also be carried out in the remote mode by means of the special control circuit. The open status is signalled by the indicator (6 - fig. 6).

7. Installation

7.1 General



Correct installation is of primary importance. The manufacturer's instructions must be carefully studied and followed. It is good practice to use gloves for handling the components during installation. All operations required for installation, putting into service, service and maintenance must be carried out by qualified personnel.



The areas through which power conductors or auxiliary circuit conductors are routed must be protected against the access of animals which could lead to damage or disservice.

7.2 Installation and operating conditions

The following Standards must be taken into particular consideration during installation and service:

- IEC60694/DIN VDE 0101
- VDE 0105: Electrical installation service
- DIN VDE 0141: Earthing systems for installations with rated voltage above 1 kV
- All the accident prevention regulations in force in the relative countries.

7.2.1 Normal conditions

Comply with the recommendations in the IEC 60694 and 62271-100 Standards. In detail:

Ambient temperature	Maximum	+ 40 °C
	Average maximum over 24 hours	+ 35 °C
	Minimum (according to class - 5), apparatus for indoor installation	- 5°
Humidity	The average value of the relative humidity, measured for more than 24 hours, must not exceed 95%.	
	The average value of the water vapour pressure, measured for more than 24 hours, must not exceed 2.2 kPa.	
	The average value of the relative humidity, measured for more than 1 month, must not exceed 90%.	
	The average value of the water vapour pressure, measured for more than 1 month, must not exceed 1.8 kPa.	
Altitude	< 1000 m above sea level	

7.2.2 Special conditions

Installations over 1000 m a.s.l.	Possible, within the limits allowed by the reduction in the dielectric strength of the air
Increase in the ambient temperature	Reduction in the rated current Encourage heat dissipation with appropriate additional ventilation
Climate	To avoid the risk of corrosion or other damage in areas: <ul style="list-style-type: none"> - with a high level of humidity, and/or - in the case of rapid and extensive temperature variations, take appropriate steps (for example, by using electric heaters) to prevent condensation from forming

Please contact ABB for special installation requirements or other operating conditions.

7.2.3 Trip curves

The following graphs show the number of vacuum interrupter closing-opening cycles (N.) allowed, depending on the breaking capacity (Ia).

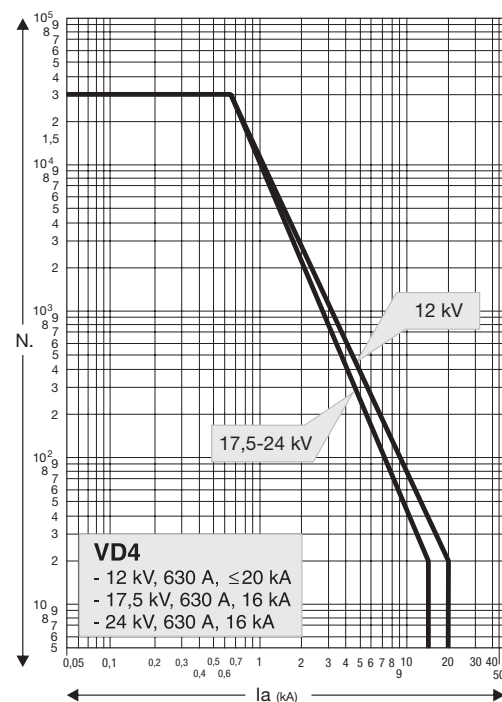

Figure 7a

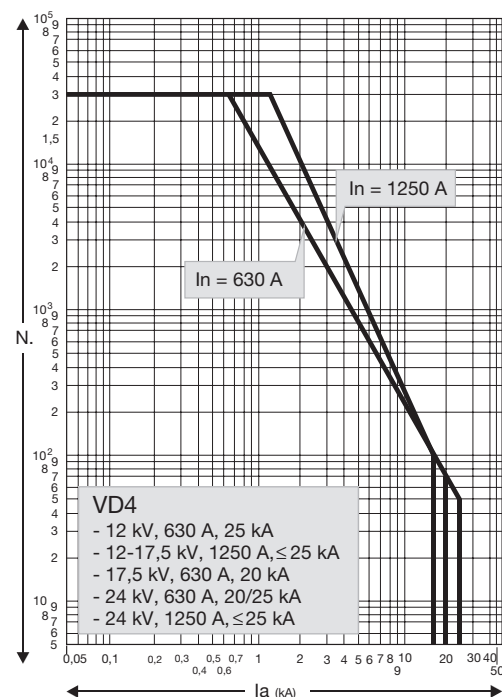

Figure 7b

Key

N. Number of closing-opening cycles allowed for the vacuum interrupters.

Ia Breaking capacity of the vacuum interrupters.

7.3 Preliminary operations

- Clean the insulating parts with clean dry rags.
- Make sure that the upper and lower terminals are clean and free of any deformation caused by shocks received during transport or storage.

7.4 Installation of fixed circuit-breakers

The circuit-breaker can be installed straight on the floor or on supporting frames provided by the customer (see fig. 8). The areas on which the supporting frames or truck (if provided) rest must be on the same plane to avoid any risk of distortion in the breaker structure.

A minimum degree of protection (IP2X) must be guaranteed from the front towards live parts.

The apparatus can be fixed in the following ways:

- by means of special expansion anchoring bolts with M8 threaded hole if the apparatus is fixed to a cement floor
- by means of M8 bolts if the apparatus is fixed to metal structures or to cement floors into which special steel sections have been embedded.

Whatever the method used, the fixing surface must be well-levelled and all the resting points must be on the same horizontal plane.

7.5 Installation of circuit-breakers for ABB switchgear

The circuit-breakers are designed for use in UniSwitch, UniAir, UniMix or UniSec switchgear. Special assembly operations are not usually required.

However, consult the documentation of the switchgear in question.

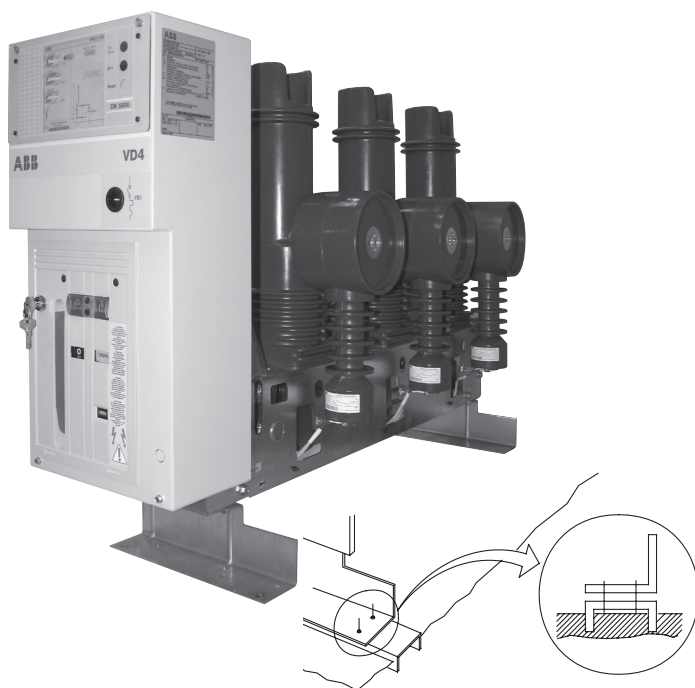

Figure 8

7.6 Power circuit connections

7.6.1 General recommendations

- Make sure that the circuit-breaker terminals are clean and are free from any deformation caused by shocks received during transport or storage.
- Choose the conductor cross-sections to suit the service and short-circuit current of the installation.
- Provide suitable supporting insulators near the fixed circuit-breaker terminals or the monoblocs of the cubicles, sized according to the electrodynamic stress caused by the short-circuit current of the installation.



The circuit-breaker terminals are always silver-plated. To clean them, use only dry rags, soaked in a suitable solvent if necessary. NOTE. Never use a file or emery cloth!

7.6.2 Maximum dimensions of the connections

For fixed version VD4 circuit-breakers, the connections must be shaped and installed in accordance with the indications given in the overall dimensions and in compliance with the distances indicated.

7.6.3 Surface treatment of the connections

The connections can be made of bare copper or bare aluminium. However, it is always advisable to silver-plate the contact surfaces.

The thickness of the surface treatment must be even and regular.

7.6.4 Assembly of the connections

- Make sure that the contact surfaces of the connections are perfectly flat and without burrs, traces of oxidation or deformities caused by drilling or impact sustained.
- Depending on the conductive material used and the surface treatment given, the operations indicated in the following table 1 must be carried out on the surface contact of the conductor.

Table 1

Bare copper	Clean with a fine file or emery cloth
	Smear a film of 5RX Moly grease over the contact surfaces
Copper or silver-plated aluminium	Clean with a rough dry cloth
	Only if there are traces of oxidation that are difficult to shift, clean with ultra-fine grain emery cloth and take care not to remove the surface layer
	Repeat the surface treatment if necessary
Bare aluminium	Clean with a metal brush or emery cloth
	Immediately smear neutral grease over the contact surfaces
	Insert a bi-metal copper-aluminium strip with beaded surfaces between the aluminium connection and the copper terminal (copper side touching the terminal, aluminium side touching the connection)

Assembly procedures

- Place the connections in contact with the circuit-breaker terminals.
- Insert a spring washer and a flat washer between the head of the bolt and the connection.
- The diameter of the flat washers must be able to distribute the torquing pressure over a wide area.
- Tighten the bolt, taking care to prevent the insulating parts from being stressed. Use of DIN class 8.8 standard bolts is recommended, also with reference to the indications in table 2.
- Make sure that the connections do not exert any force on the terminals.
- Carefully comply with the manufacturer's instructions for terminating the cables in cable connections.

Table 2

Bolt	Recommended tightening torque ⁽¹⁾	
	Without lubricant	With lubricant ⁽²⁾
M6	10 Nm	4.5 Nm
M8	30 Nm	10 Nm
M10	40 Nm	20 Nm
M12	70 Nm	40 Nm
M15	200 Nm	80 Nm

⁽¹⁾ The nominal tightening torque is based on a 0.14 friction coefficient of the thread (distributed value to which the thread is subjected and which, in some cases, is not negligible).

The nominal tightening torque with lubricant complies with DIN 43673 Standards.

⁽²⁾ Oil or grease. Thread and surfaces in contact with the lubricated heads.

Consider the deviations from the general Standards table (for example, for systems in contact or terminals) as established in the specific technical documentation.

The thread and surfaces in contact with the heads of bolts must be slightly oiled or greased, so as to obtain a correct nominal tightening torque.

7.7 Earthing

- Earth fixed version circuit-breakers by means of the special screw marked with the relative symbol. Clean and degrease the area around the screw corresponding to a diameter of about 30 mm. Use a conductor (busbar or cord) with a cross-section conforming to the Standards in force.
- When the assembly is completed, cover the joint with vase-line grease.

7.8 Connection of the auxiliary circuits

The minimum cross-section of the wires used for the auxiliary circuits must not be less than the one used for the internal cabling.

Furthermore, they must be insulated for a 2 kV test voltage at power frequency according to standard IEC 60694 sect. 6.2.10.

7.8.1 Fixed version circuit-breakers

The auxiliary circuits of the circuit-breaker must be connected by means of modular terminals installed under the cover.

The wires outside the circuit-breaker must be routed inside appropriately earthed metal tubes or ducts.



Make sure that the circuit-breaker is open and the closing springs discharged before removing the operating mechanism cover to access the terminal box, .

7.8.2 Circuit-breakers for ABB switchgear

The auxiliary circuits are fully wired in the factory through to the connector. Please refer to the wiring diagram of the switchgear for the connections.

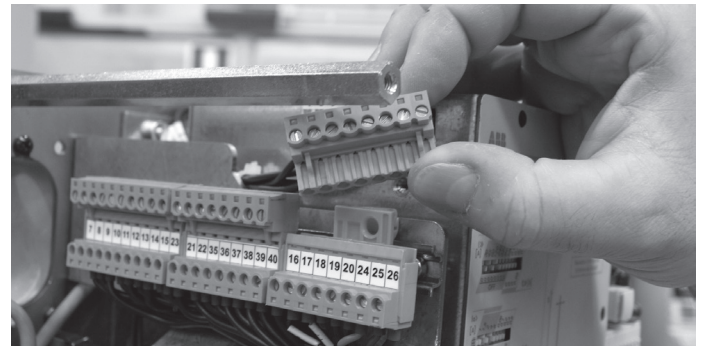

Figure 9



Figure 10

8. Putting into service

8.1 General procedures



All the operations for putting into service must be carried out by ABB personnel or by the customer's qualified personnel. If the operations are obstructed, do not force the mechanical interlocks and check that the operating sequence is correct. The operating forces which can be applied are indicated in paragraph 6.3. Discharge the closing springs (close and open the circuit-breaker) to access the inside of the operating mechanism. Disconnect the PR521 release (if provided) before conducting insulation tests on the circuit-breaker.

Prima di mettere in servizio l'interruttore eseguire le seguenti operazioni:

- verificare il serraggio delle connessioni di potenza ai terminali dell'interruttore;
- stabilire la taratura dello sganciatore di massima corrente primario elettronico (se previsto);
- controllare che il valore della tensione di alimentazione dei circuiti ausiliari sia compreso per c.a. tra l'85% e il 110% per c.c. tra il 70% e il 110% della tensione nominale delle applicazioni elettriche;
- verificare che tra gli organi mobili non siano penetrati corpi estranei quali residui di imballaggio;
- verificare che nel luogo di installazione sia assicurato un sufficiente ricambio d'aria per evitare sovratemperature;
- eseguire inoltre i controlli riportati nella seguente tabella:

	Subject of the inspection	Procedure	Positive check
1	Insulation resistance.	Medium voltage circuit Using a 2500 V Megger, measure the insulation resistance between the phases and between phases and earth the circuit.	The insulation resistance should be at least 50 MΩ and must remain constant over time.
		Auxiliary circuits Using a 500 V Megger (installed equipment permitting), measure the insulation resistance between the auxiliary circuits and the earth.	The insulation resistance should be several MΩ and must remain constant over time.
2	Auxiliary circuits.	Make sure that the connections to the control circuit are correct: proceed with the relative power supply.	Normal operations and signals.
3	Manual operating mechanism.	Perform a few closing and opening operations (see chap. 6). NOTE. Power the undervoltage release and the locking magnet on the operating mechanism at the relative rated voltage (if provided).	The operations and relative signals occur correctly.
4	Motor operator (if provided).	Power the spring loading gearmotor at the relative rated voltage.	The springs are loaded correctly. The signals are correct. The gearmotor stops when the springs have been loaded.
		Perform a few closing and opening operations. NOTE. Power the undervoltage release and the locking magnet on the operating mechanism at the relative rated voltage (if provided).	The gearmotor reloads the springs after each closing operation.
5	Undervoltage release (if provided).	Power the undervoltage release at the relative rated voltage and perform the circuit-breaker closing operation.	The circuit-breaker closes correctly. The signals are correct.
		Disconnect the power supply to the release.	The circuit-breaker opens. The signal changes over.
6	Shunt opening release and additional shunt opening release (if provided).	Close the circuit-breaker. Power the shunt opening release at the relative rated voltage.	The circuit-breaker opens correctly. The signals are correct.
7	Shunt closing release (if provided).	Open the circuit-breaker. Power the shunt closing release at the relative rated voltage.	The circuit-breaker closes correctly. The signals are correct.
8	Key lock.	Open the circuit-breaker, keep the opening pushbutton depressed, then turn the key and remove it from the housing. Attempt the circuit-breaker closing operation.	Neither manual nor electric closing takes place.
		Insert the key again and turn it through 90°. Perform the closing operation.	Both electric and manual closing take place correctly; in this position the key cannot be removed.
9	Auxiliary contacts in the operating mechanism.	Insert the auxiliary contacts into suitable signalling circuits. Perform a few closing and opening operations.	The signals occur correctly.

9. Maintenance

The purpose of the maintenance operations is to keep the apparatus in a good working condition for as long as possible.

The following operations must be performed, as specified in Standards IEC 61208 / DIN 31 051.

Inspection: Establishing the real conditions

Overhaul: Measures to be taken to maintain the specific conditions

Repair: Measures to be taken to restore the specific conditions.

9.1 General

Vacuum circuit-breakers are characterised by simple, sturdy construction and a long life.

The operating mechanism is maintenance-free for its whole operating life, and only requires functional inspections (see sect. 9.2.2).

The vacuum interrupters are maintenance-free for their whole operating life.

Vacuum interruption does not produce any harmful effects even when there are frequent interruptions at the rated and short-circuit current.

The interventions during service and their aim are determined by the ambient conditions, by the sequence of operations and by the shortcircuit interruptions.

Note

Comply with the following Standards for maintenance work:

- the relative specifications given in the chapter on “Standards and Specifications”;
- labour safety regulations in the chapter on “Putting into service and operations”;
- standards and specifications of the country where the apparatus is installed.

The maintenance operations must only be carried out by trained personnel who comply with all the safety regulations. Furthermore, it is advisable to have ABB personnel at least check the performance during service and carry out any repairs required. Cut the power supply off and put the apparatus under safe conditions during the maintenance operations.



Before proceeding with any operation, make sure that the circuit-breaker is open, with the springs discharged and that it is not powered (medium voltage circuit and auxiliary circuits).

9.1.1 Operating life

The operating life expectancy of VD4 circuit-breakers is as follows:

- vacuum interrupters: up to 30,000 operations, depending on the type (see sect. 7.2.3 Trip curves);
- actuator and transmission system: up to 10,000 operations, under normal operating conditions, depending on the type of circuit-breaker and with regular maintenance.

9.2 Inspections and functionality tests

9.2.1 Interruption devices in general

- Assess the conditions of the interruption devices by conducting regular inspections.
- Inspection at fixed intervals can be avoided when the apparatus is permanently under the control of qualified personnel.
- Firstly, the assessments must include visual inspection to check for any contamination, traces of corrosion or electrical discharge phenomena.
- Perform a more frequent inspections when there are unusual operating conditions (including severe climatic conditions) and in the case of environmental pollution (e.g. high level of contamination or an atmosphere with aggressive agents).
- Visual inspection of the isolating contacts. The contact system should be turned alternately in order to keep the internal surface of the contact areas clean. The contact areas must be cleaned when there are signs of overheating (discoloured surface) (also consult the Repairs section).
- Conduct overhauls if the conditions are abnormal (see Overhauling section).

9.2.2 Stored energy operating mechanism

Subject the operating mechanism to a functional after 5,000 operations or after 4 years.

Before performing the test, open the circuit-breaker and de-energise the medium voltage circuit.

Note

Insulate the work area and make it safe, following the safety regulations specified in the IEC/DIN VDE Standards.

Functional test

- Carry out a few opening and closing operations with the circuit-breaker not connected to the load.
- If provided, cut off the power supply to the spring loading motor. Discharge the springs by closing and opening the circuit-breaker by means of the closing and opening push-buttons.
- Visually inspect the lubrication conditions of the jaw isolating contacts, of the sliding surfaces, etc.
- Make sure that the electrical and mechanical operation of the various devices is correct, with particular attention to the interlocks.
- The screws and nuts are tightened in the factory and correct tightening is indicated with a coloured mark. No further tightening operations should be required during the operating life of the circuit-breaker. However, if, following interventions, it should be necessary to retighten the screws or nuts, make sure that you comply with the values indicated in fig. 11.

9.2.3 Circuit-breaker pole

No further inspections are necessary beyond those already described sect. 9.2.1.

9.3 Overhaul

9.3.1 Interruption devices in general

Comply with the following procedure if the devices had to be cleaned during the inspections, as specified in sect. 9.2.1:

- insulate the work area and make it safe, following the safety regulations specified in the IEC/DIN VDE Standards;
- generally clean the surfaces:
 - dry and remove light deposits of dirt with a soft dry cloth;
 - more resistant deposits of dirt can be removed using slightly alkaline domestic type detergent or Rivolta BWR 210 detergent;
- clean the insulating surfaces and conductive parts:
 - light dirt: with Rivolta BWR 210 detergent;
 - stubborn dirt: with cold detergent type 716.

After cleaning, thoroughly rinse with clean water and dry carefully.

Note

Only use detergents without halogens and never 1.1.1-trichloroethane, trichloroethylene or carbon tetrachloride!

9.3.2 Actuator and transmission system:

Circuit-breakers up to 25 kA

The actuator (trip box), the shock-absorber and all the other components of the transmission system (shaft, main levers, locking rings, etc.) must be completely replaced after 10,000 operations.

Note

Dismantling and replacement of the operating mechanism (trip box) can only be carried out by ABB personnel or by skilled and specially trained personnel, particularly as regards the necessary adjustments.

Details about overhauling

- When required, cut off the power supply to the spring loading motor and discharge the springs of the operating mechanism in the manual mode by closing and opening the circuit-breaker.
- Replace the parts subjected to mechanical stress or stress due to particular environmental conditions, (contact an ABB service centre).

Note

These operations can only be carried out by ABB personnel or by skilled and specially trained personnel.

9.3.3 Circuit-breaker pole

The circuit-breaker pole and relative vacuum interrupter are maintenance-free until the maximum number of electrical operations for the type of interrupter is reached (see sect. 7.2.3 Trip curves).

The operating life of the vacuum interrupter is defined by the sum of the ultimate currents corresponding to the specific type of interrupter in accordance with the indications in the graphs of sect. 7.2.3 Trip curves: when the sum of the ultimate currents is reached, the whole pole must be replaced.

Note

Dismantling and replacement of the pole can only be carried out by ABB personnel or by skilled and specially trained personnel, particularly as regards the necessary adjustments.

To perform the interrupter test without dismantling the circuit-breaker pole, use:

- VIDAR tester for the vacuum test, manufactured by Pro-gramma Electric GmbH, Bad Homburg v.d.H.

The following VIDAR tester test values are valid for the interrupter vacuum test:

Rated voltage of the circuit-breaker	D.c. test voltage
12 kV	40 kV
17.5 kV	40 kV
24 kV	60 kV

The test must always be carried out with the circuit-breaker open with the contacts at the nominal distance (12 to 17.5 kV). Procedure for testing the degree of vacuum of the interrupter of the circuit-breaker poles:

- turn off the power supply and make the working area safe by following the safety instructions specified in the IEC/DIN VDE Standards;
- open the circuit-breaker;
- earth a terminal of each circuit-breaker pole;
- connect the earth terminal of the VIDAR tester to the circuit-breaker structure;
- connect the high voltage terminal of the VIDAR tester to the terminal of the circuit-breaker pole not connected to earth (L1 phase) and conduct the test. Repeat the test for phases L2 and L3.

Note

The tester connection cables can produce an indication due to the capacitive effect. In this case the cables must not be removed.

9.4 Repairs section

Replacement of spare parts and accessories must only be carried out by ABB personnel or suitably qualified and specially trained personnel.

Always work with the circuit-breaker open and locked so that it cannot be closed again, with the work area insulated and made safe.

The springs of the operating mechanism must be discharged.

All power supply sources must be disconnected and made safe to prevent them from reclosing during the removal and installation work.



If maintenance is carried out by the customer's personnel, responsibility for the interventions remains with the customer.

Replacement of parts not included in the "List of spare parts/accessories" (sect. 12.1) must only be carried out by ABB personnel.

In particular:

- complete pole with bushings/connections
- actuator and transmission system
- closing spring set
- opening spring
- shock-absorber.

Screw tightness inspection

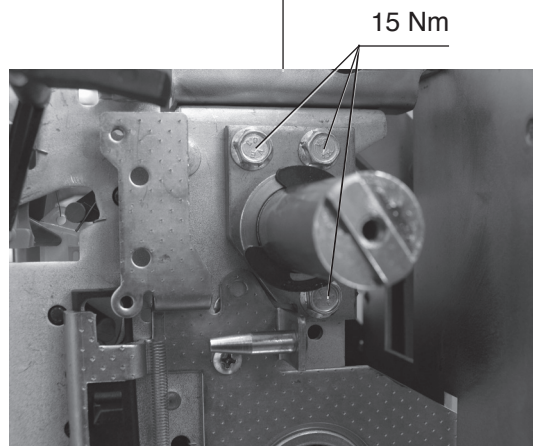
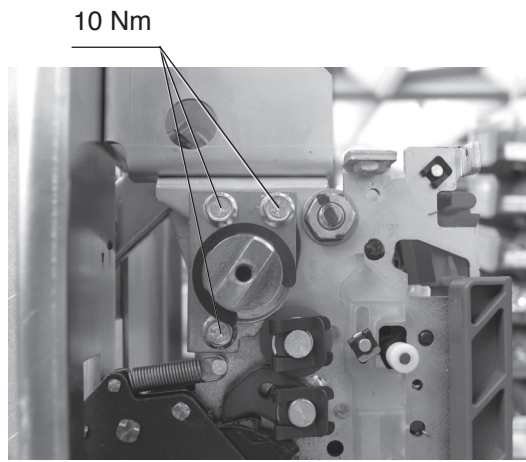
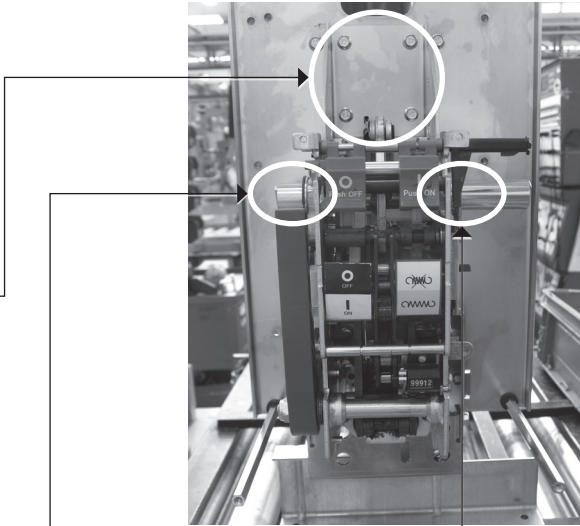
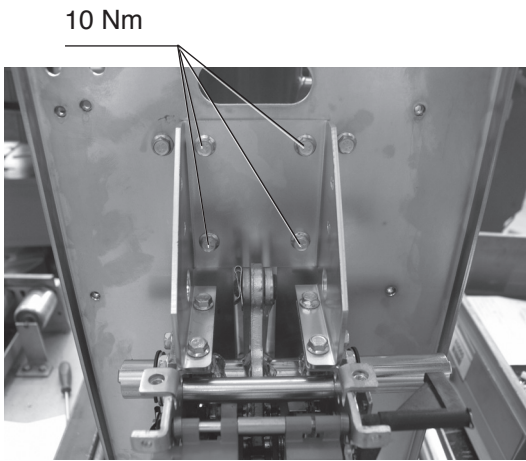

Figure 11

10. Application of the X-ray emission Standards

One of the physical properties of vacuum insulation is that X-rays could be emitted when the interrupter contacts are open. The specific tests conducted at the PTB laboratories (Physikalisch-Technische Bundesanstalt, in Brunswick - Germany) show that local emission at a distance of 10 cm from the interrupter or pole surface, does not exceed 1 $\mu\text{Sv/h}$.

This means that:

- use of vacuum interrupters is absolutely safe at the rated service voltage;
- application of the withstand voltage at power frequency, ac-

ording to the IEC 62271-100 and VDE 0670 Standards, is safe;

- application of a voltage higher than the withstand voltage at power frequency or of a test voltage in direct current, specified in the IEC and VDE Standards, cannot be used;
- limitation of the above-mentioned local phenomena, with interrupters with open contacts, depends on maintaining the specific distance between the contacts.

This condition is intrinsically guaranteed by correct operation of the operating mechanism and by the adjustments of the transmission system.

11. Spare parts and accessories



All assembly operations of spare parts/accessories must be carried out in accordance with the instructions enclosed with the spare parts themselves, by ABB personnel or by suitably qualified customer personnel with in-depth knowledge of the apparatus (IEC 60694) and of all the Standards aimed at ensuring that these interventions are carried out in safe conditions. If maintenance is carried out by the customer's personnel, responsibility for the interventions remains with the customer. Before proceeding with any operation, always make sure that the circuit-breaker is open, the springs discharged and that it is not energised (medium voltage circuit and auxiliary circuits).

When ordering circuit-breaker spare parts/accessories, refer to the ordering sales codes indicated in the technical catalogue and always state the following:

- type of circuit-breaker
- rated voltage of the circuit-breaker
- rated nominal current of the circuit-breaker
- breaking capacity of the circuit-breaker
- serial number of the circuit-breaker
- rated voltage of any electrical spare parts.

Please contact our Service office to check on availability and to order spare parts.

11.1 List of spare parts

- Opening release
- Supplementary opening release
- Undervoltage release
- Contact for signalling undervoltage release energised/de-energised
- Time delay device for undervoltage release
- Mechanical override for undervoltage release
- Closing release
- Spring loading geared motor with electrical signalling of springs loaded
- Gearmotor thermomagnetic protection circuit-breaker
- Contact for signalling gearmotor protection circuit-breaker open/closed
- Contact for signalling closing springs loaded/discharged
- Auxiliary contacts of the circuit-breaker
- Opening solenoid
- Open position key lock
- Opening pushbutton protection
- Closing pushbutton protection
- Set of six main isolating contacts
- Current sensors for PR521
- PR521 protection releases
- K7 sensors for REF601
- REF601 protection releases
- Connector complete with sheath
- Wheel Kit
- Operation counter
- Complete pole.

12. Overall dimensions

Fixed circuit-breaker with rh lateral operating mechanism - 12-17.5-24 kV pole center-distance P = 230 mm

TN 1VCD000100

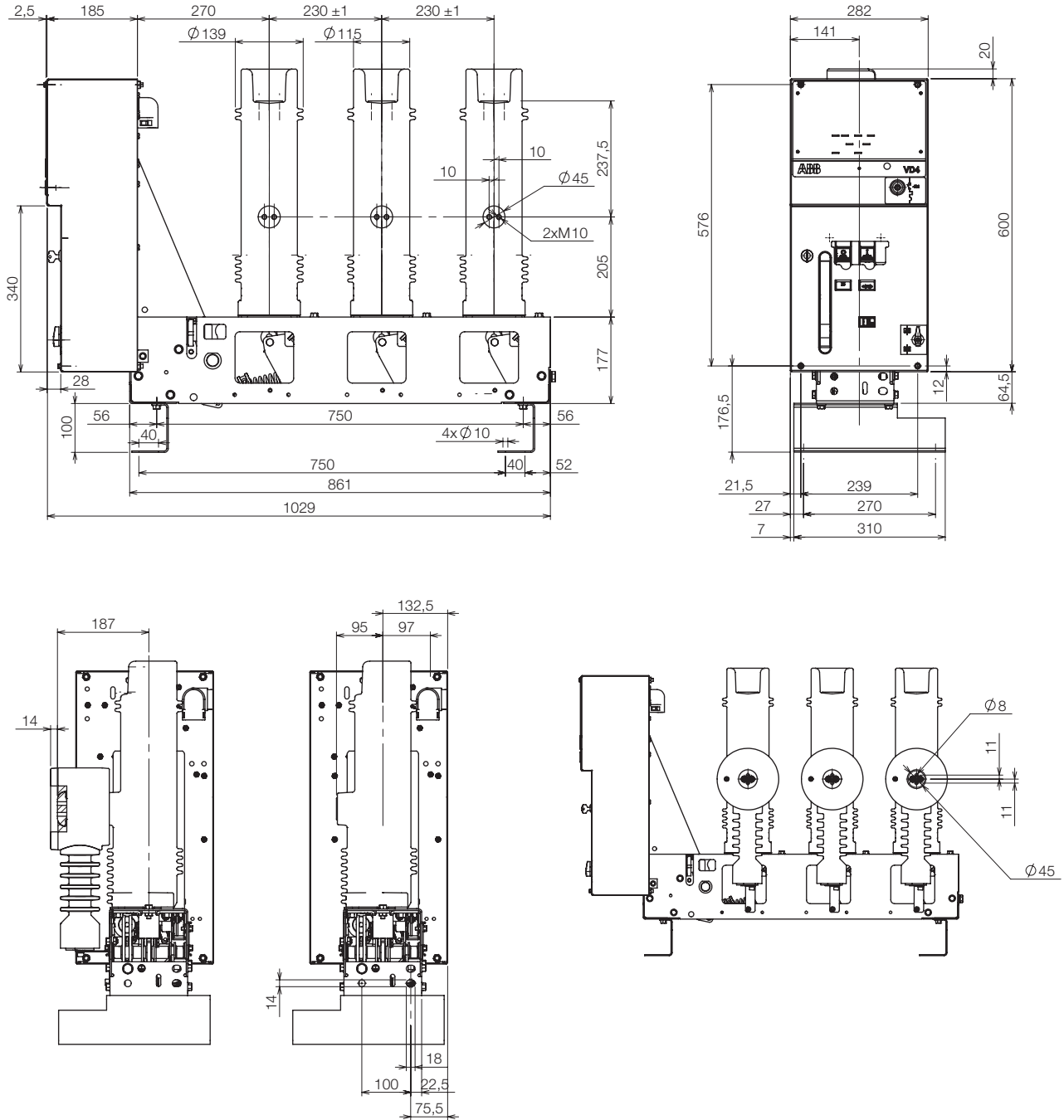

Fixed circuit-breaker with lh lateral operating mechanism - 12-17.5-24 kV pole center-distance P = 230 mm

TN 1VCD003453

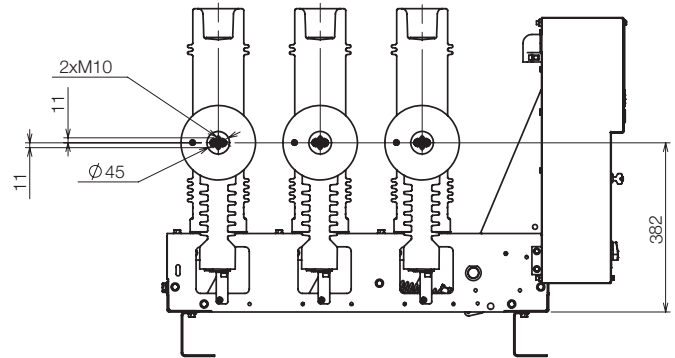
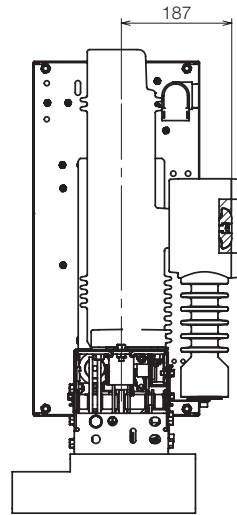
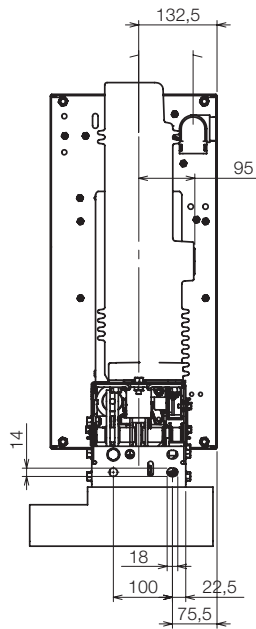
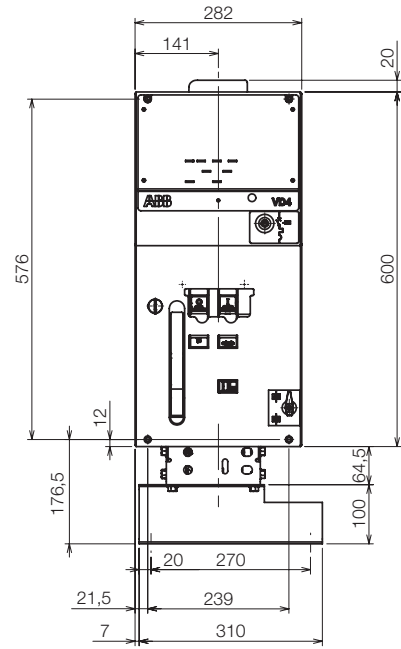
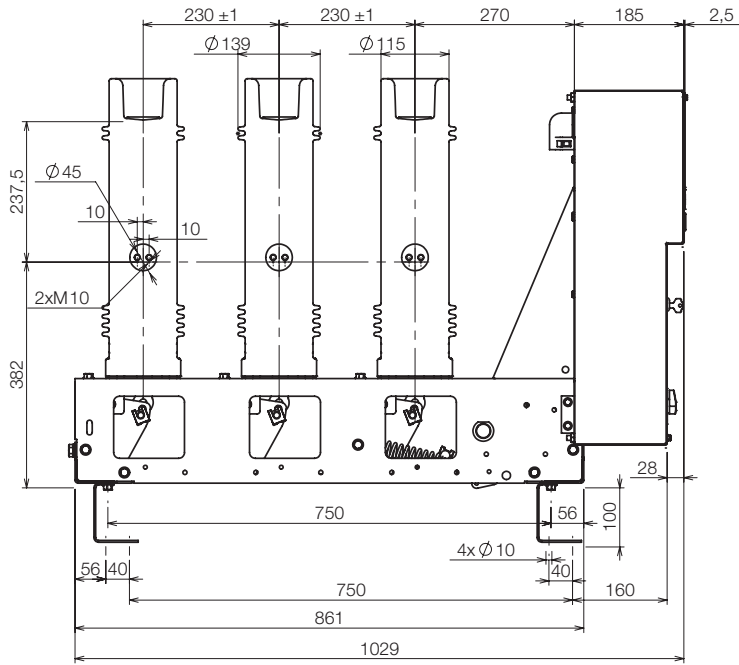

TN 1VCD000101

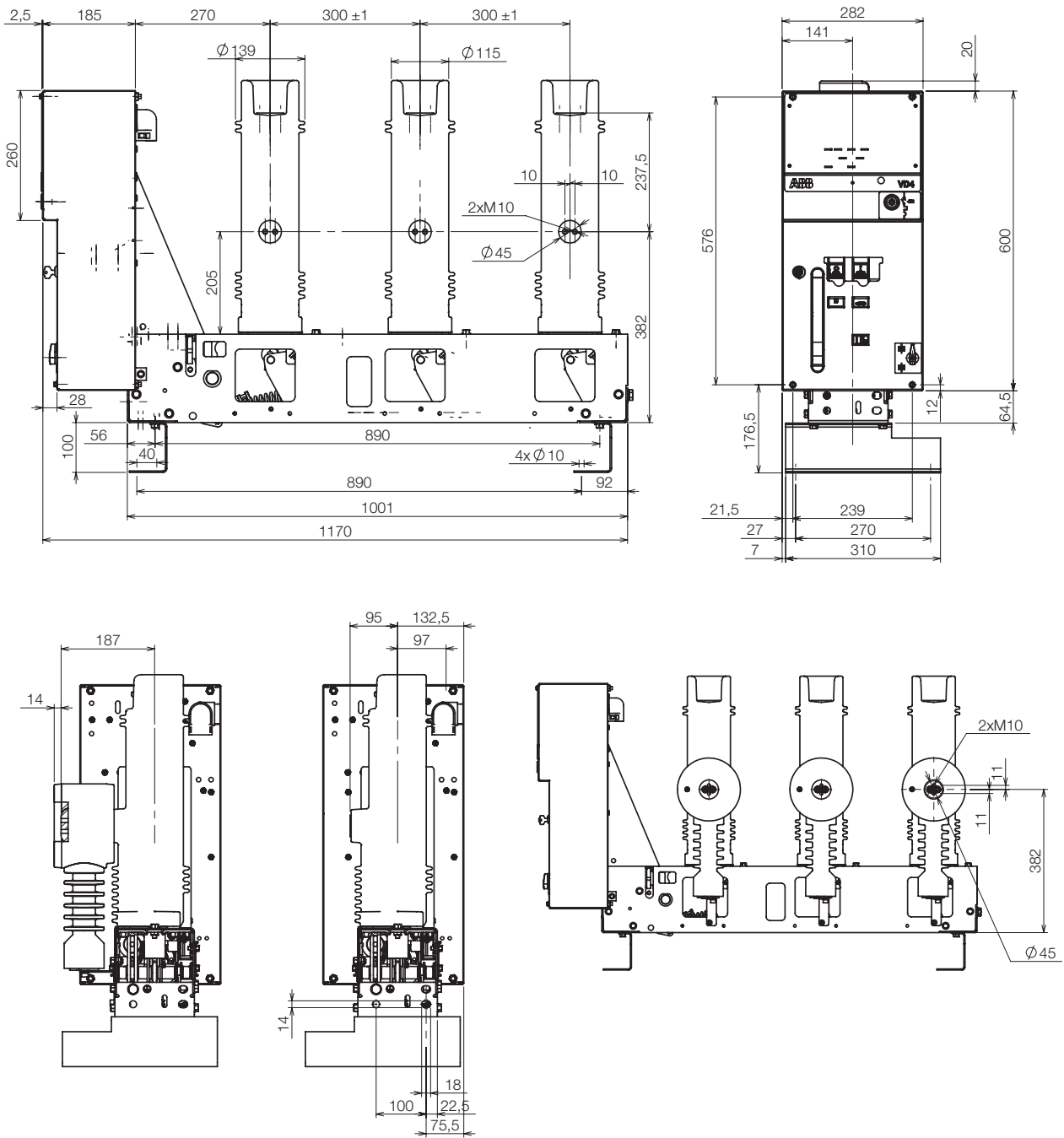

Fixed circuit-breaker for UniSwitch switchgear - rh lateral operating mechanism - 12-17.5-24 kV pole center-distance
P = 210 mm

TN 1VCD000098

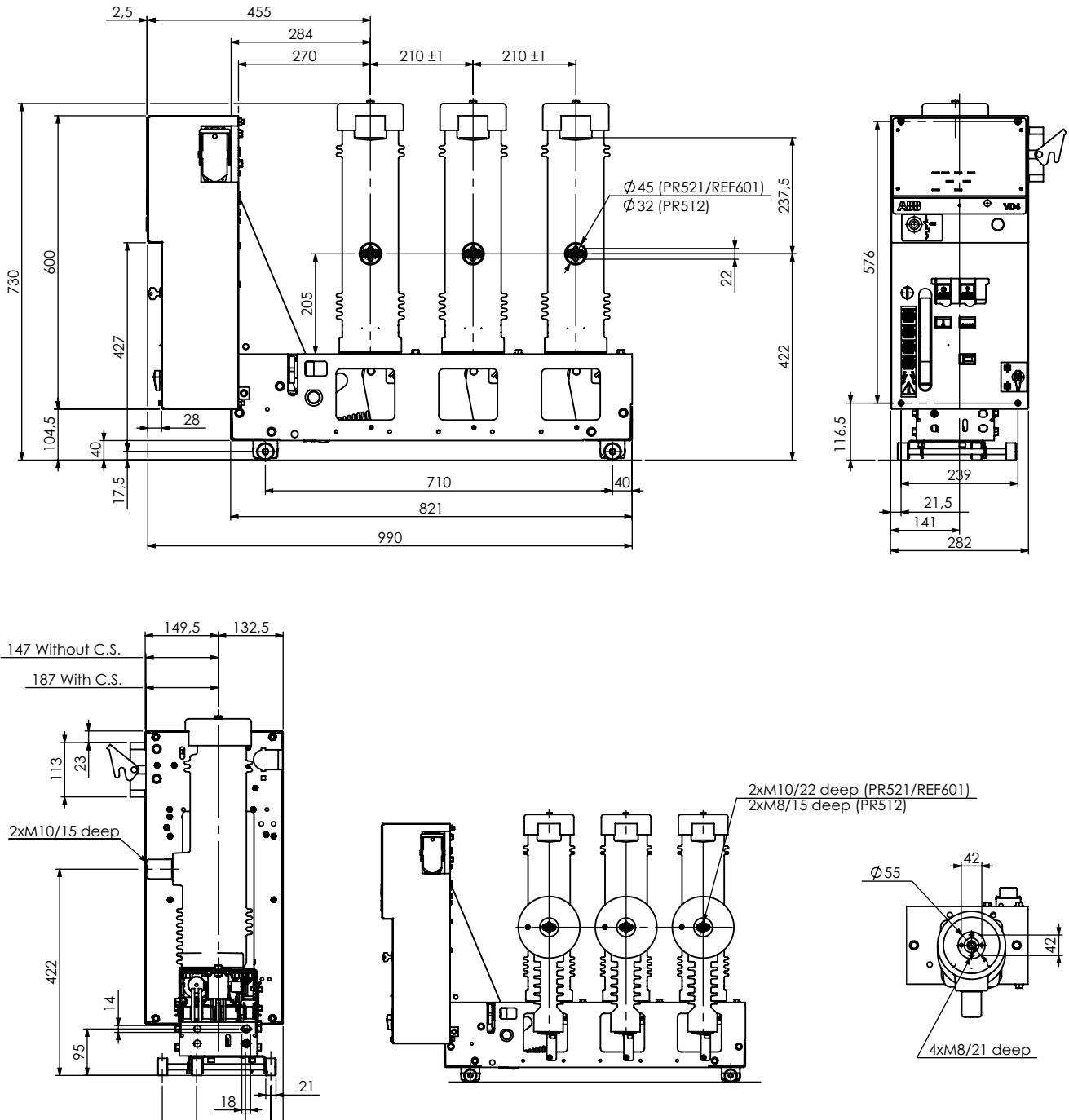

Fixed circuit-breaker for UniAir switchgear - P1/E unit - rh lateral operating mechanism - 12-17.5-24 kV
pole center-distance P = 300 mm

TN 1VCD000102

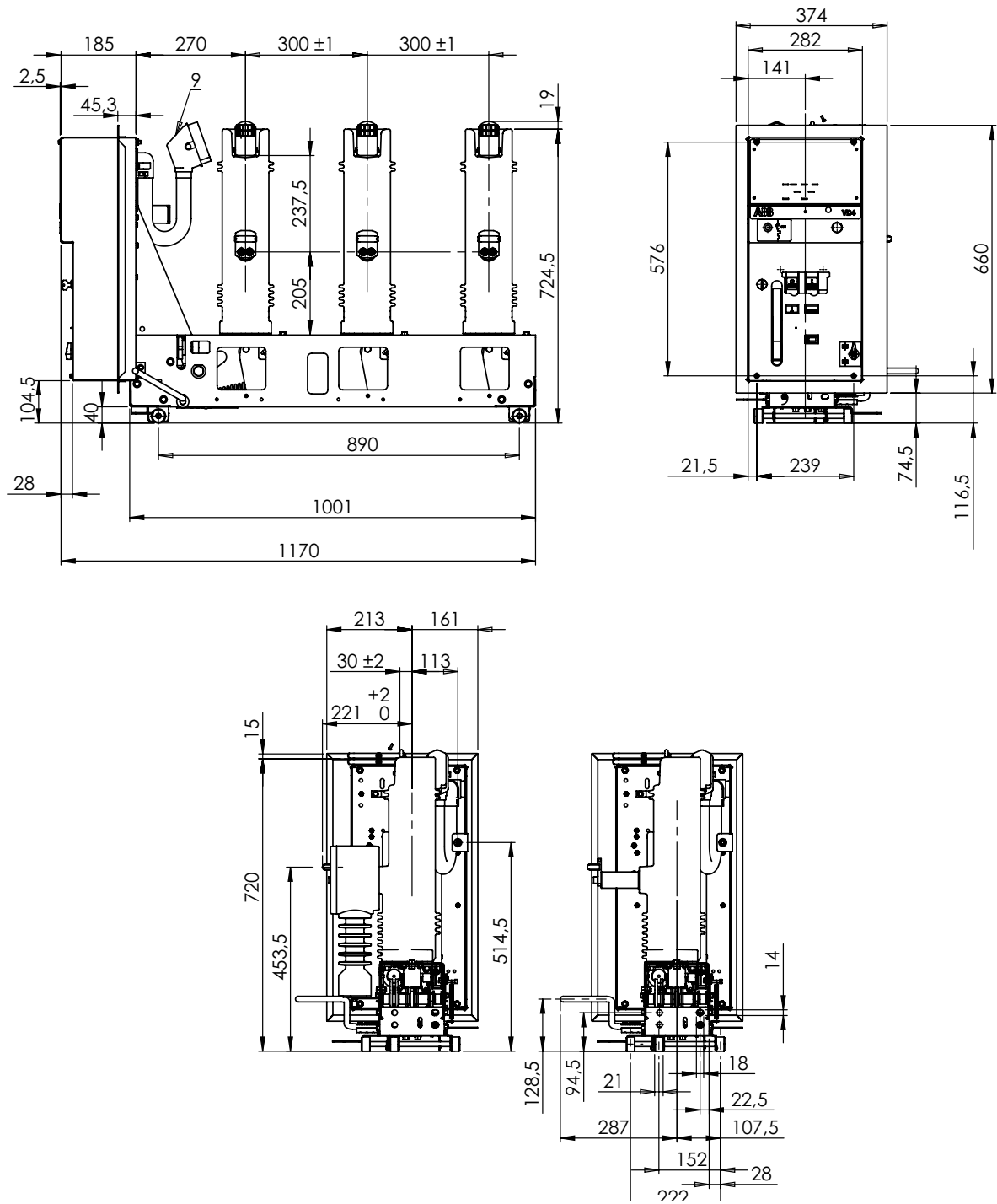

Fixed circuit-breaker for UniAir switchgear - P1E/2R unit - rh lateral operating mechanism - 12-17.5-24 kV
pole center-distance P = 300 mm

TN 1VCD000103

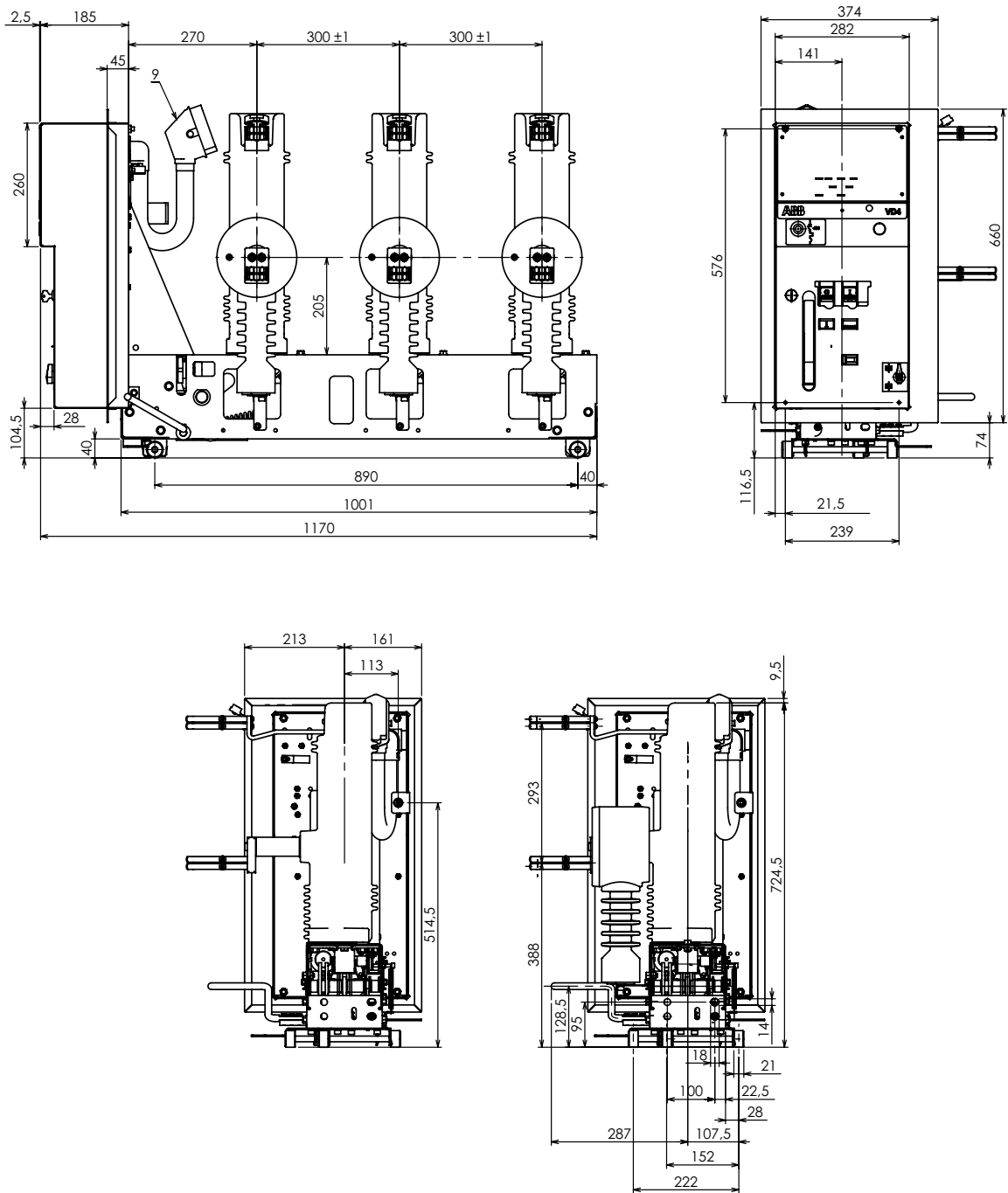

Fixed circuit-breaker for UniAir switchgear - P1/A unit - rh lateral operating mechanism - 12-17.5-24 kV
pole center-distance P = 300 mm

TN 1VCD000104

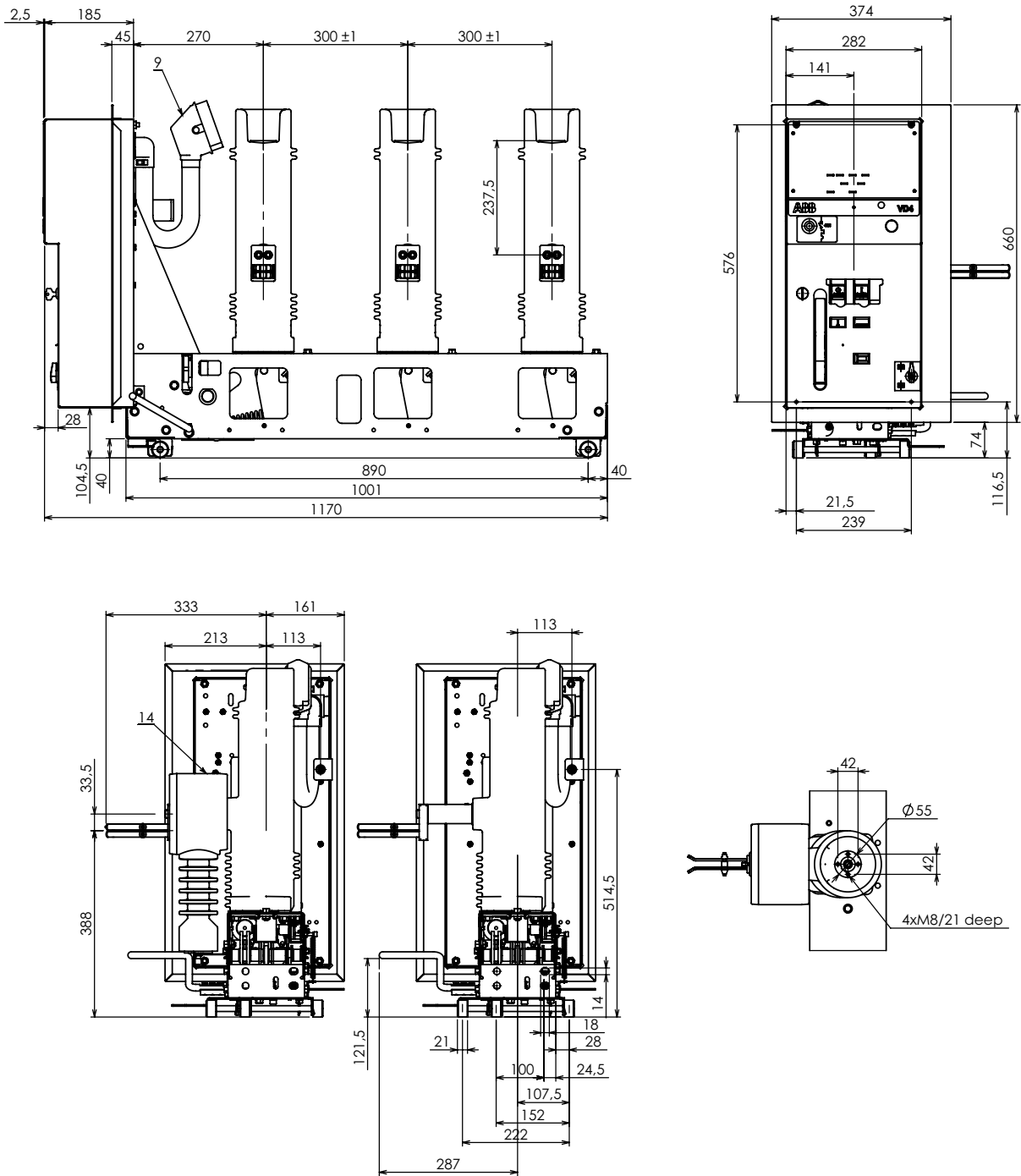

Fixed circuit-breaker for UniAir switchgear - P1/F unit - rh lateral operating mechanism - 12-17.5-24 kV
pole center-distance P = 300 mm

TN 1VCD000105

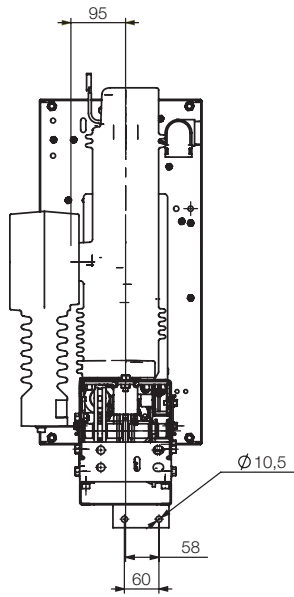
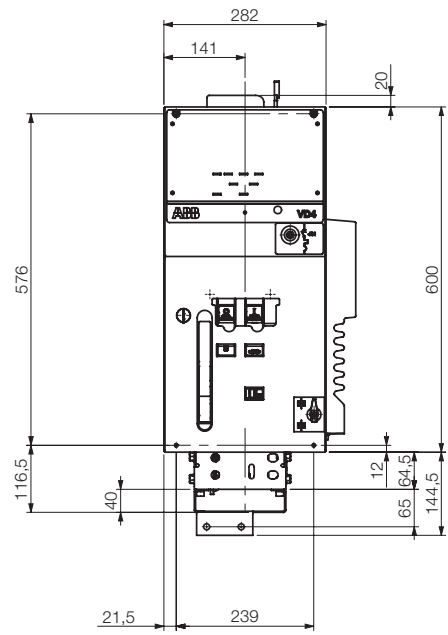
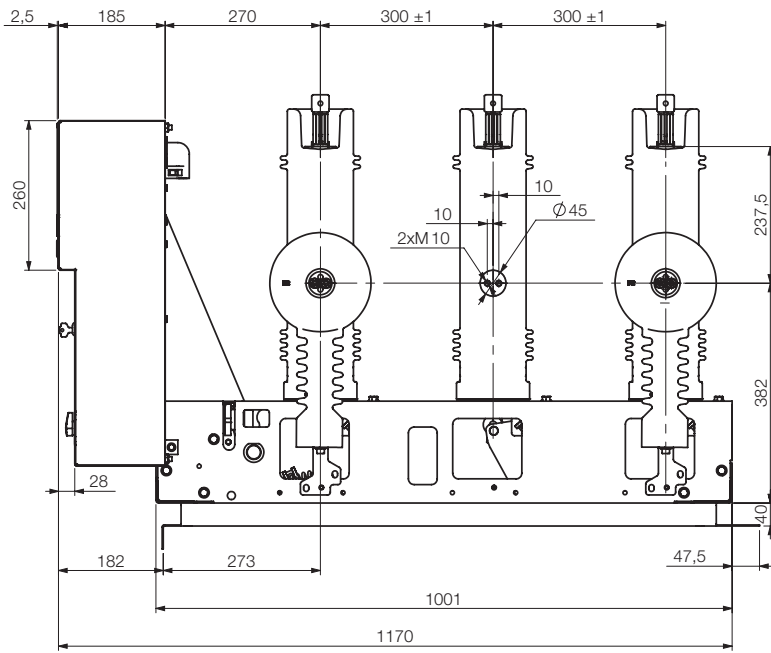

Fixed circuit-breaker for UniSec switchgear - rh lateral operating mechanism - 12-17.5-24 kV
pole center-distance P = 230 mm

TN 1VCD000131

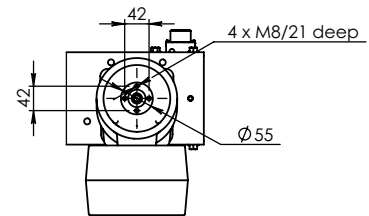
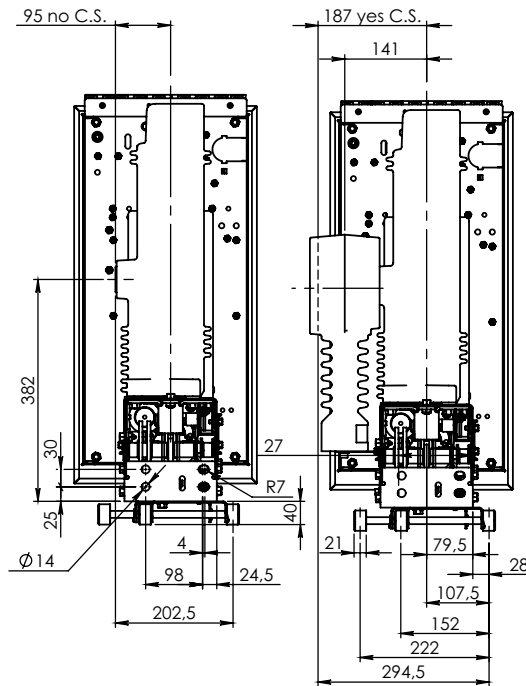
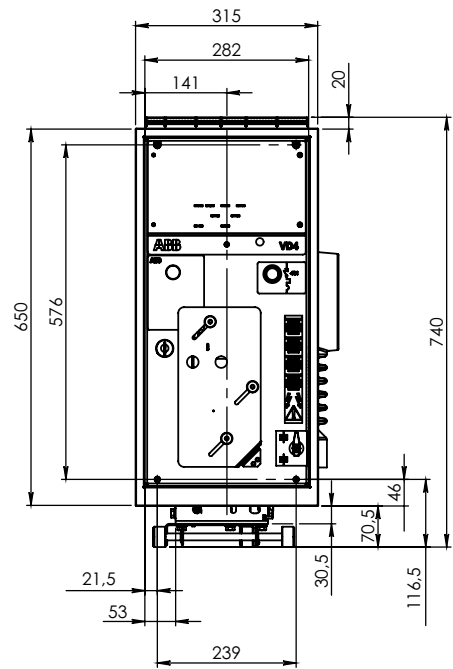
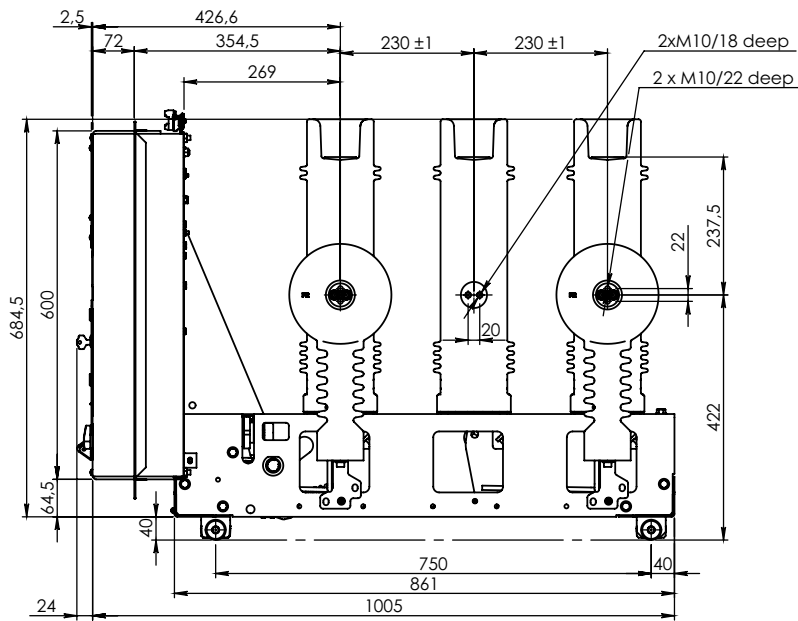

Fixed circuit-breaker for UniSec switchgear - 1h lateral operating mechanism - 12-17.5-24 kV
pole center-distance P = 230 mm

TN 1VCD000132

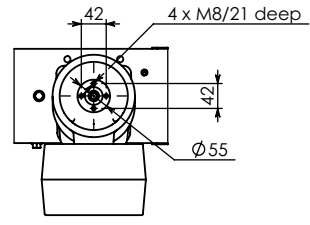
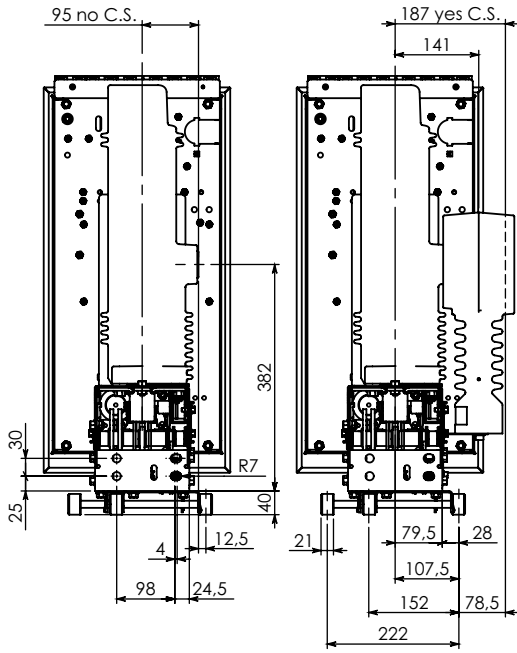
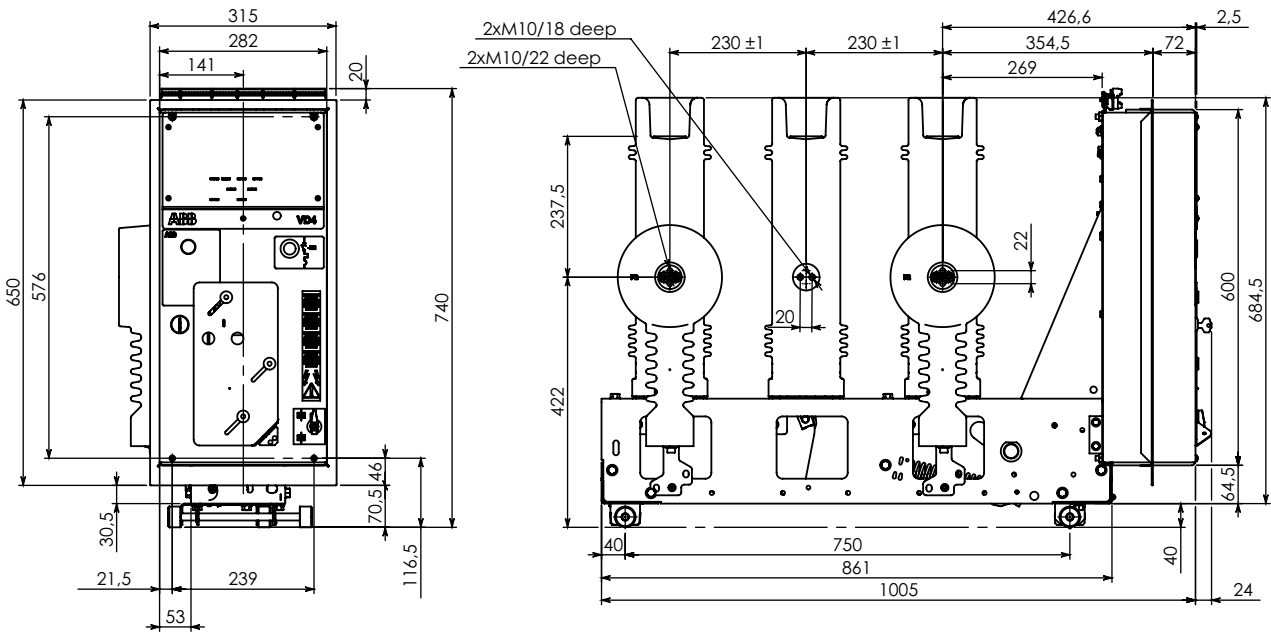

Detail of control front

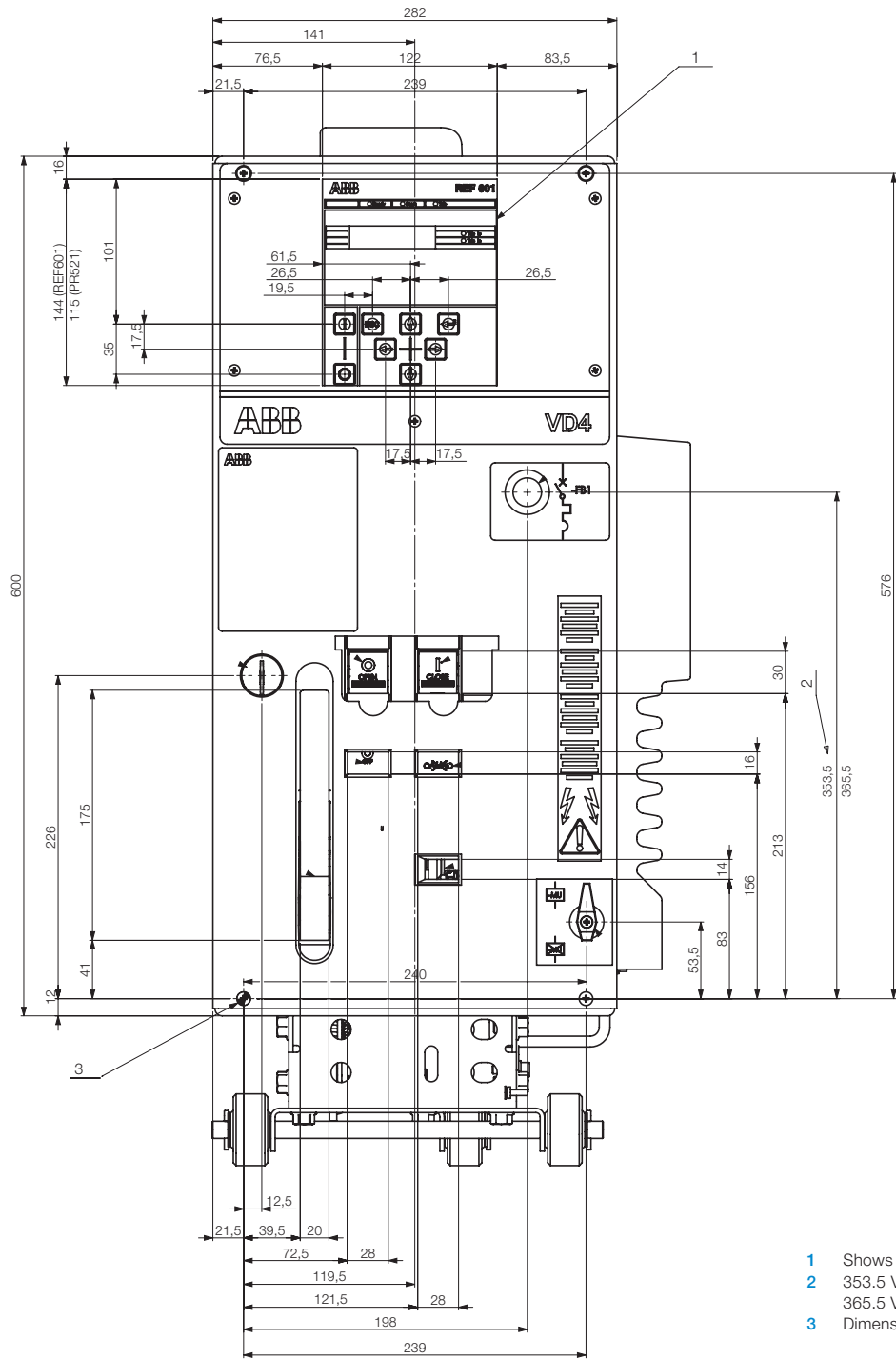

13. Quality of the products and environmental protection

The apparatus is manufactured in accordance with the requirements established by the international standards concerning quality management and environmental management systems. The level of excellence in these fields is testified by the ISO 9001 and ISO 14001 certificates available.

End of life of the products

ABB undertakes to comply with the environmental protection requirements established by law, in accordance with the matters established by the ISO 14001 Standards.

ABB provides its skills and assistance to facilitate the recycling and disposal process for products at the end of their life. It is always necessary to comply with the local regulations when disposing of products.

Disposal methods

The products can be disposed of by means of heat treatments, in incineration systems or by storage in dedicated areas.

Material	Recommended disposal method
Metals (Fe, Cu, Al, Ag, Zn, W, other)	Separation and recycling
Thermoplastics	Recycling or disposal
Epoxy resin	Separation of the metal parts, disposal of the resin parts
Rubber	Disposal
Wood for packaging	Recycling or disposal
Aluminium foil for packaging	Recycling or disposal

For further details please contact:

ABB S.p.A.

**Power Products Division
Unità Operativa Sace-MV**

Via Friuli, 4

I-24044 Dalmine

Tel: +39 035 6952 111

Fax: +39 035 6952 874

E-mail: info.mv@it.abb.com

www.abb.it

ABB AG

Calor Emag Medium Voltage Products

Oberhausener Strasse 33

D-40472 Ratingen

Phone: +49(0)2102/12-1230

Fax: +49(0)2102/12-1916

E-mail: powertech@de.abb.com

www.abb.de/calor

The data and illustrations are not binding. We reserve the right to modify the contents of this document without prior notice following technical and product developments.

© Copyright 2015 ABB.
All rights reserved.